



A PROUD TRADITION | A BRIGHT FUTURE

REGULAR BOARD MEETING

Tuesday, January 23, 2018

7:00 PM

James Steenbergen, President • Kathryn Kaminski, Vice President • Kay Danziger, Secretary
Mandi Bronsell • Dr. Tyson Harrell • Joe Hubenak • Melisa Roberts

**LAMAR CISD BOARD OF TRUSTEES
REGULAR BOARD MEETING
BRAZOS CROSSING ADMINISTRATION BUILDING
3911 AVENUE I, ROSENBERG, TEXAS
JANUARY 23, 2018
7:00 PM**

AGENDA

1. Call to order and establishment of a quorum
2. Opening of meeting
3. Recognitions/awards
4. Introductions
5. Audience to patrons
6. Approval of minutes
 - A. December 12, 2017 - Special Meeting (Workshop) 6
 - B. December 19, 2017 - Special Meeting (Workshop) 8
 - C. December 21, 2017 - Regular Board Meeting 11
7. Board members reports
 - A. Meetings and events
8. Superintendent reports
 - A. Meetings and events
 - B. Information for immediate attention
9. Public Hearing - LCISD Accountability Performance Report for 2016-2017
10. **ACTION ITEMS**
 - A. **Goal: Planning**
 1. Consider approval of Quarterly Investment Report 19
 2. Consider approval of the Lamar Consolidated Independent School District Comprehensive Annual Financial Report for the 2016 - 2017 year 26
 3. Consider ratification of Financial and Investment Reports 27
 4. Consider approval of purchase of band and orchestra instruments, equipment, related items and services 31
 5. Consider approval of catering and banquet services 33
 6. Consider approval of Board Calendar for 2018 35
 7. Consider approval of resolutions proclaiming:
 - a. Black History Month 37
 - b. Career and Technical Education Month 39
 - c. School Counselor Week 41
 8. Consider approval of amendment to the Texas General Land Office agreement for the emergency interruptible load service program 43
 9. Consider approval of CenterPoint Energy terms and conditions for Foster 56

High School Natatorium	
10. Consider approval of CenterPoint Energy terms and conditions and facilities extension agreement for Fulshear High School Natatorium	84
11. Consider approval of materials testing for Culver Elementary School	101
12. Consider approval of base cost increase for refurbished moving van semi-trailers	114
11. INFORMATION ITEMS	
A. Goal: Planning	
1. Board Policies for First Reading	116
2. TASB 2016-2018 Advocacy Agenda	236
3. Tax Collection Report	237
4. Payments for Construction Projects	243
5. Bond Update	246
6. Projects funded by 2011 available bond funds	256
7. Transportation Update	257
8. Proposed Budget Calendar	260
9. Holdsworth Center Update	262
12. CLOSED SESSION	
A. Adjournment to closed session pursuant to Texas Government Code Sections 551.071, 551.072, 551.074, and 551.082, the Open Meetings Act, for the following purposes: (Time _____)	
1. Section 551.074 - For the purpose of considering the appointment, employment, evaluation, reassignment, duties, discipline or dismissal of a public officer or employee or to hear complaints or charges against a public officer or employee.	263
a. Approval of personnel recommendations for employment of professional personnel	
b. Employment of professional personnel (Information)	264
c. Employee resignations and retirements (Information)	265
d. Superintendent's Evaluation and Contract	
2. Section 551.072 - For the purpose of discussing the purchase, exchange, lease or value of real property	
a. Land	
3. Section 551.071 - To meet with the District's attorney to discuss matters in which the duty of the attorney to the District under the Texas Disciplinary Rules of Professional Conduct of the State Bar of Texas clearly conflicts with the Open Meetings Act, including the grievance/complaint hearing.	
a. Any item listed on the agenda	
b. Discuss pending, threatened, or potential litigation, including school finance litigation	
RECONVENE IN OPEN SESSION	

**Action on Closed Session Items
Future Agenda Items
Upcoming Meetings and Events**

ADJOURNMENT: (Time _____)

If during the course of the meeting covered by this notice, the Board should determine that a closed session of the Board should be held or is required in relation to an item noticed in this meeting, then such closed session as authorized by Section 551.001 et seq. of the Texas Government Code (the Open Meetings Act) will be held by the Board at that date, hour or place given in this notice or as soon after the commencement of the meeting covered by this notice as the Board may conveniently meet in such closed session concerning any and all subjects and for any and all purposes permitted by Section 551.071-551.084, inclusive, of the Open Meetings Act, including, but not limited to:

Section 551.084 - For the purpose of excluding witness or witnesses from a hearing during examination of another witness.

Section 551.071 - For the purpose of a private consultation with the Board's attorney on any or all subjects or matters authorized by law.

Section 551.072 - For the purpose of discussing the purchase, exchange, lease or value of real property.

Section 551.073 - For the purpose of considering a negotiated contract for a prospective gift or donation.

Section 551.074 - For the purpose of considering the appointment, employment, evaluation, reassignment, duties, discipline or dismissal of a public officer or employee or to hear complaints or charges against a public officer or employee.

Section 551.082 - For the purpose of considering discipline of a public school child or children or to hear a complaint by an employee against another employee if the complaint or charge directly results in a need for a hearing.

Section 551.076 - To consider the deployment, or specific occasions for implementation, of security personnel or devices.

Section 551.083 - For the purpose of considering the standards, guidelines, terms or conditions the Board will follow, or instruct its representatives to follow, in consultation with representatives of employee groups in connection with consultation agreements provided for by Section 13.901 of the Texas Education Code.

Section 551.0821 – For the purpose of deliberating a matter regarding a public school student if personally identifiable information about the student will necessarily be revealed by the deliberation.

Should any final action, final decision or final vote be required in the opinion of the Board with regard to any matter considered in such closed session, then such final action, final decision or final vote shall be at either:

- a. the open meeting covered by this notice upon the reconvening of this public meeting, or
- b. at a subsequent public meeting of the Board upon notice thereof, as the Board may determine.

CERTIFICATE AS TO POSTING OR GIVING OF NOTICE

On this 19th day of January 2018 at 3:00 p.m., this notice was posted on a bulletin board located at a place convenient to the public in the central administrative offices of the Lamar Consolidated Independent

School District, 3911 Avenue I, Rosenberg, Texas 77471, and in a place readily accessible to the general public at all times.

Karen Vacek

Karen Vacek
Secretary to Superintendent

Special Meeting

Be It Remembered

The State of Texas §
County of Fort Bend §
Lamar Consolidated Independent School District §

Notice of Special Meeting Held

On this the 12th day of December 2017, the Board of Trustees of the Lamar Consolidated Independent School District of Fort Bend County, Texas met in Special Session (Workshop) in Rosenberg, Fort Bend County, Texas.

1. CALL TO ORDER AND ESTABLISHMENT OF A QUORUM

This meeting was duly called to order by the President of the Board of Trustees, Mr. James Steenbergen, at 6:00 p.m.

Members Present:

James Steenbergen	President
Kathryn Kaminski	Vice President
Kay Danziger	Secretary
Mandi Bronsell	Member
Tyson Harrell	Member
Joe Hubenak	Member
Melisa Roberts	Member

Others Present:

Thomas Randle	Superintendent
Kevin McKeever	Administrator for Operations
Jill Ludwig	Chief Financial Officer

BUSINESS TRANSACTED

Business properly coming before the Board was transacted as follows: to witness—

2. ACTION ITEMS

2. A. GOAL: PLANNING

2. A-1 Operational Audit Report

Mr. Odysseus Lanier, partner from McConnell & Jones LLP, presented the operational audit report.

Ms. Kaminski arrive 7:10 p.m.

Minutes of Special Board Meeting December 19, 2017 – page 31

The Board recessed at 7:10 p.m.

The Board reconvened at 7:23 p.m.

2. A-2 Governance Team (Board and Superintendent) Team Building and Self-Assessment

Ms. Kate Rogers and Dr. Lindsay Whorton, from the Holdsworth Center, presented the workshop on team building and self-assessment.

ADJOURNMENT TO CLOSED SESSION PURSUANT TO TEXAS GOVERNMENT CODE SECTIONS 551.071, 551.072, 551.074, and 551.082, THE OPEN MEETINGS ACT, FOR THE FOLLOWING PURPOSES:

1. Section 551.074 – For the purpose of considering the appointment, employment, evaluation, reassignment, duties, discipline or dismissal of a public officer or employee or to hear complaints or charges against a public officer or employee.
2. Section 551.072 – For the purpose of discussing the purchase, exchange, lease or value of real property
3. Section 551.071 – To meet with the District’s attorney to discuss matters in which the duty of the attorney to the District under the Texas Disciplinary Rules of Professional Conduct of the State Bar of Texas clearly conflicts with the Open Meetings Act, including the grievance/complaint hearing.

The Board did not convene in Closed Session.

ADJOURNMENT

The meeting adjourned at 8:51 p.m.

LAMAR CONSOLIDATED INDEPENDENT SCHOOL DISTRICT

Signed:

James Steenbergen
President of the Board of Trustees

Kay Danziger
Secretary of the Board of Trustees

Special Meeting

Be It Remembered

The State of Texas §
County of Fort Bend §
Lamar Consolidated Independent School District §

Notice of Special Meeting Held

On this the 19th day of December 2017, the Board of Trustees of the Lamar Consolidated Independent School District of Fort Bend County, Texas met in Special Session (Workshop) in Rosenberg, Fort Bend County, Texas.

1. CALL TO ORDER AND ESTABLISHMENT OF A QUORUM

This meeting was duly called to order by the President of the Board of Trustees, Mr. James Steenbergen, at 6:30 p.m.

Members Present:

James Steenbergen President
Kathryn Kaminski Vice President
Kay Danziger Secretary
Mandi Bronsell Member
Joe Hubenak Member
Melisa Roberts Member

Members Absent:

Tyson Harrell Member

Others Present:

Thomas Randle Superintendent
Kevin McKeever Administrator for Operations
Jill Ludwig Chief Financial Officer
Linda Lane Executive Director of Elementary Education
Leslie Haack Executive Director of Secondary Education
Kathleen Bowen Chief Human Resources Officer
Mike Rockwood Executive Director of Community Relations
David Jacobson Chief Technology Information Officer
Valerie Vogt Chief Academic Officer

BUSINESS TRANSACTED

Business properly coming before the Board was transacted as follows: to witness—

Minutes of Special Board Meeting December 19, 2017 – page 33

2. Discussion of December 21st Regular Board Meeting Agenda Items

The Board reviewed the December 21st Regular Board Meeting agenda items.

11. ACTION ITEMS

11. A GOAL: PLANNING

11. A-5 Consider approval of base cost increase for refurbished moving van semi-trailers

Ms. Roberts asked if we have any idea of how many trailers will be needed. Dr. Randle said George Ranch has its own and Fulshear is in the bond. We are looking at the other three so they have the same size and type trailer. Ms. Danziger asked about a ballpark figure. Mr. Estrada said no more than \$85,000. Dr. Randle said these are 53' trailers and they have been renting equipment. The District feels like offsetting the rental costs will help pay for the additional cost of the trailer. Ms. Roberts asked if this will take a special type of driver. Mr. Jones said they already have drivers with Class A licenses. The District has one truck purchased currently and will use budget money for the other trucks. The purchase of the trailers will be done as the budget funds are available.

11. A-10 Consider approval of MUD No. 184 agreements and fees for Carter Elementary School

Ms. Roberts asked what happens if we go over the 800 capacity. Mr. McKeever said this protects us for a long time, we have never gone over. Ms. Kaminski asked what is the capacity for Carter. Mr. McKeever said 750.

3. AUDIENCE TO PATRONS

None

ADJOURNMENT TO CLOSED SESSION PURSUANT TO TEXAS GOVERNMENT CODE SECTIONS 551.071, 551.072, 551.074, and 551.082, THE OPEN MEETINGS ACT, FOR THE FOLLOWING PURPOSES:

1. Section 551.074 – For the purpose of considering the appointment, employment, evaluation, reassignment, duties, discipline or dismissal of a public officer or employee or to hear complaints or charges against a public officer or employee.
 - a. Approval of personnel recommendations for employment of professional personnel
 - b. Employment of professional personnel (Information)
 - c. Employee resignations and retirements (Information)
 - d. Reassignment of professional personnel (Information)
2. Section 551.072 – For the purpose of discussing the purchase, exchange, lease or value of real property
 - a. Land
3. Section 551.071 – To meet with the District's attorney to discuss matters in which the duty of the attorney to the District under the Texas Disciplinary Rules of Professional Conduct of the State Bar of Texas clearly conflicts with the Open Meetings Act, including the grievance/complaint hearing.
 - a. Any item listed on the agenda
 - b. Discuss pending, threatened, or potential litigation, including school finance litigation

Minutes of Special Board Meeting December 19, 2017 – page 34

The Board did not convene in Closed Session.

ADJOURNMENT

The meeting adjourned at 6:46 p.m.

LAMAR CONSOLIDATED INDEPENDENT SCHOOL DISTRICT

Signed:

James Steenbergen
President of the Board of Trustees

Kay Danziger
Secretary of the Board of Trustees

Regular Meeting

Be It Remembered

The State of Texas §
County of Fort Bend §
Lamar Consolidated Independent School District §

Notice of Regular Meeting Held

On this the 21st day of December 2017, the Board of Trustees of the Lamar Consolidated Independent School District of Fort Bend County, Texas met in Regular Session in Rosenberg, Fort Bend County, Texas.

1. CALL TO ORDER AND ESTABLISHMENT OF A QUORUM

This meeting was duly called to order by the President of the Board of Trustees, Mr. James Steenbergen, at 7:00 p.m.

Members Present:

James Steenbergen	President
Kathryn Kaminski	Vice President
Kay Danziger	Secretary
Mandi Bronsell	Member
Tyson Harrell	Member
Joe Hubenak	Member
Melisa Roberts	Member

Others Present:

Thomas Randle	Superintendent
Kevin McKeever	Administrator for Operations
Jill Ludwig	Chief Financial Officer
Linda Lane	Executive Director of Elementary Education
Leslie Haack	Executive Director of Secondary Education
Kathleen Bowen	Chief Human Resources Officer
Mike Rockwood	Executive Director of Community Relations
David Jacobson	Chief Technology Information Officer
Valerie Vogt	Chief Academic Officer
Rick Morris	Attorney

BUSINESS TRANSACTED

Business properly coming before the Board was transacted as follows: to witness—

2. OPENING OF MEETING

A moment of silence was observed and asked they remember former board member, Frank Torres. The pledge of allegiance was recited.

3. STUDENT REPORTS: 1621 – Service Project

The following students from 1621 presented: Jesus Garza, Asia Vasquez, Reese Gray, and Mysunique Turner

4. RECOGNITIONS/AWARDS

None

5. INTRODUCTIONS

Dr. Kathleen Bowen introduced new staff to the Board:
Carsen Collins, assistant principal at Lamar Jr. High School

6. AUDIENCE TO PATRONS

Mr. Larry Moten addressed the Board about his concerns for property taxes, the 2017 bond, Holdsworth Center being free, and the release of the audit book.

7. APPROVAL OF MINUTES

A. NOVEMBER 14, 2017 SPECIAL BOARD MEETING (WORKSHOP)

It was moved by Ms. Danziger and seconded by Ms. Kaminski that the Board of Trustees approve the minutes of November 14, 2017 Special Board Meeting (Workshop). The motion carried unanimously.

B. NOVEMBER 16, 2017 REGULAR BOARD MEETING

It was moved by Ms. Roberts and seconded by Mr. Hubenak that the Board of Trustees approve the minutes of November 16, 2017 Regular Board Meeting. The motion carried unanimously.

8. BOARD MEMBER REPORTS

a. Meetings and Events

Ms. Bronsell reported the Policy Committee met and reported on the changes to Update 108.

Ms. Roberts reported the Attendance Boundary Committee met and has a committee being proposed for Carter Elementary School.

Ms. Danziger reported the Facilities Committee met and reported the status of projects in the District. She attended the Lindsey Elementary School dedication ceremony.

Mr. Hubenak reported the Technology Committee met and reported the status of projects in the District.

Mr. Steenberg attended the inaugural orchestra concerts at Navarro and Wertheimer Middle Schools.

9. SUPERINTENDENT REPORTS

- a. **Meetings and Events**
- b. **Information for Immediate Attention**

10. Public Hearing on Financial Integrity Rating System of Texas (FIRST) for fiscal year 2015 - 2016

The hearing was opened at 7:19 p.m. Jill Ludwig, Chief Financial Officer gave a brief overview on the Financial Integrity Rating System of Texas for fiscal year 2015-2016. There being no more discussion, the hearing was closed to the public at 7:32 p.m.

ACTION ITEMS FOR CONSENT OF APPROVAL: 11. A-1 – 11. A-3; 11. A-6 – 11. A-15; 11. B-1 – 11. B-2; and 11. C-1.

It was moved by Ms. Danziger and seconded by Mr. Steenbergen that the Board of Trustees approve these action items as presented. The motion carried unanimously.

11. A GOAL: PLANNING

11. A-1 Ratification of Financial and Investment Reports

Ratified the Financial and Investment reports as presented.

11. A-2 Approval of budget amendment requests

Approved budget amendment requests as attached. (See inserted page 37-A.)

11. A-3 Approval of Board Policies - Second Reading

- a. **Localized Policy Manual Update 108**
- b. **EFA (EXHIBIT A) Request for reconsideration of instructional materials**
- c. **EFA (EXHIBIT B) Reconsideration of instructional materials committee report**
- d. **FFA (LOCAL) Student Welfare: Wellness and Health Services**

Approved the second reading of the following policies:

Localized Policy Manual Update 108
EFA (EXHIBIT A) Request for reconsideration of instructional materials
EFA (EXHIBIT B) Reconsideration of instructional materials committee
FFA (LOCAL) Student Welfare: Wellness and Health Services

(See inserted pages 37-B—37-V.)

11. A-6 Approval of final payment for the Agricultural Facility #2

Approved the final payment of \$30,001.95 to BLS Construction, Inc. and change order #1 for a no cost time extension, for the construction of Agricultural Facility #2. (See inserted page 37-W.)

11. A-7 Approval of CenterPoint Energy blanket easement for Carter Elementary School

Approved the CenterPoint Energy blanket easement for the installation of overhead and underground electric service at Carter Elementary School and authorized the Board President to execute easement documents. (See inserted pages 38-A—38-K.)

11. A-8 Approval of CenterPoint Energy gas development fees for Cater Elementary School

Approved the CenterPoint Energy gas development fees for Carter Elementary School and approved the payment in the amount of \$64,701.82.

11. A-9 Approval of CenterPoint Energy blanket easement for the Natatorium at Fulshear High School

Approved the CenterPoint Energy blanket easement and service order for the installation of overhead and underground electric service at the Natatorium at Fulshear High School and authorized the Board President to execute easement documents and service order. (See inserted pages 38-L—38-W.)

11. A-10 Approval of MUD No. 184 agreements and fees for Carter Elementary School

Approved the capacity agreement, application, non-taxable user fee, meters and inspection fees of the Fort Bend County MUD #184 for Carter Elementary School and approved the payment in the amount of \$253,936.94, and authorized the Board President to execute the agreement. (See inserted pages 38-X—38-NN.)

11. A-11 Approval of commissioning agent for Roberts Middle School

Approved Estes, McClure & Associates as commissioning agent for Roberts Middle School in the amount of \$26,500 and authorized the Board President to execute the agreement. (See inserted pages 38-OO—38-PP.)

11. A-12 Approval of commissioning agent for Culver Elementary School

Approved Estes, McClure & Associates as commissioning agent for Culver Elementary School in the amount of \$27,200 and authorized the Board President to execute the agreement. (See inserted pages 38-QQ—38-RR.)

11. A-13 Approval of additional materials testing for Lamar Consolidated High School band hall addition

Approved Terracon, Inc. for additional materials testing for Lamar Consolidated High School band hall addition in the amount of \$6,500 and authorized the Board President to execute the agreement. (See inserted pages 38-SS—38-UU.)

11. A-14 Approval of amendment #4 to RFQuote #18-2016LN HVAC full coverage maintenance and service agreement

Approved the amendment #4 to the RFQ #18-2016LN full coverage maintenance and service agreement with Texas AirSystems in the amount of \$12,400 per year and authorized the Board President to execute the agreement. (See inserted page 38-VV.)

11. A-15 Approval of Attendance Boundary Committee

Approved the membership of the Attendance Boundary Committee (ABC) for 2017-2018 as presented with the proposed timeline using the LCISD Zoning Process, and charged the ABC with setting the boundaries for Carter Elementary for the 2018-2019 school year.

11. B GOAL: TECHNOLOGY

11. B-1 Approval of security camera purchases

Approved the purchase of security cameras, installation of hardware, network cabling, and installation services not to exceed the amount of \$25,000.

11. B-2 Approval of interactive panel and projector purchases

Approved the purchase of interactive panels, projectors, installation hardware, and installation services not to exceed the amount of \$25,000.

11. C GOAL: PERSONNEL

11. C-1 Approval of new appraisers for teaching staff, 2017-2018 school year

Approved the 2017-2018 appraiser(s) who have recently become certified or are new to Lamar Consolidated Independent School District (LCISD).

11. A GOAL: PLANNING

11. A-4 Consider approval of nomination of candidate for position on the Texas Association of School Boards (TASB) Board of Directors

It was moved by Dr. Harrell and seconded by Ms. Bronsell that the Board of Trustees approved the nomination of Ms. Kay Danziger for Position C on the Texas Association of School Boards (TASB) Board of Directors. The motion carried unanimously.

11. A-5 Consider approval of base cost increase for refurbished moving van semi-trailers

It was moved by Ms. Kaminski and seconded by Ms. Danziger that the Board of Trustees approve increasing the base cost amount approved in August 2017 for refurbished moving van trailers from \$35,000 to any amount required, along with the approval for budget amendments as necessary to purchase same.

Ms. Roberts has concerns about this being changed from \$35,000 to any amount required, this appears to be frivolous. She would ask the board to consider having administration come back with more definite numbers and a more equitable plan to distribute to the campus.

Motion withdrawn.

It was moved by Ms. Roberts and seconded by Ms. Kaminski that the Board of Trustees postpone this agenda item to a future meeting. The motion carried unanimously.

11. A-16 Consider approval of the Lamar Consolidated Independent School District Operational Audit Report I

It was moved by Ms. Roberts and seconded by Ms. Kaminski that the Board of Trustees accept the Lamar Consolidated Independent School District Operational Audit Report.

Ms. Roberts informed the public that the audit book was not necessarily available to the privileged few, it was a committee of three board members and the rest had not seen it until it was presented. It was not an operating document that could be given to the public until the report was accepted by the Board. She said this audit opened their eyes to things, a lot they already knew, but this will help them strategically plan for the future.

Ms. Danziger said like anything else, this will be a working document. This is something that will help the District for years to come and help the District move down the road for the next 10 years. It is not something that can be implemented overnight.

The motion carried unanimously.

12. INFORMATION ITEMS

12. A GOAL: COMMUNICATIONS

12. A-1 School Board Recognition Month

(See inserted page 40-A.)

12. B GOAL: PERSONNEL

12. B-1 Report on Board Member Training

As of this date, the Lamar CISD Board members have the following current (since last year's report) and accumulated certified training credit:

	Current	Accumulated	Total
Mandi Bronsell	20.50		20.50
Kay Danziger	31.50	131.75	163.25
Tyson Harrell	11.50	36.00	47.50
Joe Hubenak	19.50		19.50
Kathryn Kaminski	23.00	143.50	166.50
Melisa Roberts	15.00	41.25	56.25
James Steenbergen	24.25	55.75	80.00

12. C GOAL: INSTRUCTIONAL

12. C-1 2017-2018 Summer School

12. C-2 School Health Advisory Council Annual Report

12. D GOAL: PLANNING

12. D-1 Lamar Education Awards Foundation (L.E.A.F.) Update

12. D-2 Tax Collection Report

12. D-3 Payments for Construction Projects

12. D-4 Bond Update

12. D-5 Projects funded by 2011 available bond funds

12. D-5 Transportation Update

ADJOURNMENT TO CLOSED SESSION PURSUANT TO TEXAS GOVERNMENT CODE SECTIONS 551.071, 551.072, 551.074, and 551.082, THE OPEN MEETINGS ACT, FOR THE FOLLOWING PURPOSES:

1. Section 551.074 – For the purpose of considering the appointment, employment, evaluation, reassignment, duties, discipline or dismissal of a public officer or employee or to hear complaints or charges against a public officer or employee.
 - a. Approval of personnel recommendations for employment of professional personnel
 - b. Employment of professional personnel (Information)
 - c. Employee resignations and retirements (Information)
 - d. Reassignment of professional personnel (Information)
2. Section 551.072 – For the purpose of discussing the purchase, exchange, lease or value of real property
 - a. Land
3. Section 551.071 – To meet with the District’s attorney to discuss matters in which the duty of the attorney to the District under the Texas Disciplinary Rules of Professional Conduct of the State Bar of Texas clearly conflicts with the Open Meetings Act, including the grievance/complaint hearing.
 - a. Any item listed on the agenda
 - b. Discuss pending, threatened, or potential litigation, including school finance litigation

The Board adjourned to Closed Session at 7:48 p.m. for the purposes listed above.

RECONVENE IN OPEN SESSION – ACTION ON CLOSED SESSION

The Board reconvened in Open Session at 8:09 p.m.

FUTURE AGENDA ITEMS

Readdressing the CMA

UPCOMING MEETINGS AND EVENTS

None

ADJOURNMENT

The meeting adjourned at 8:10 p.m.

LAMAR CONSOLIDATED INDEPENDENT SCHOOL DISTRICT

Signed:

James Steenbergen
President of the Board of Trustees

Kay Danziger
Secretary of the Board of Trustees

**CONSIDER RATIFICATION OF QUARTERLY INVESTMENT REPORT
SEPTEMBER 2017 THROUGH NOVEMBER 2017**

RECOMMENDATION:

That the Board of Trustees ratify the quarterly investment report as submitted for the quarter ending November 30, 2017.

IMPACT/RATIONALE:

This report is required by state law and local policy CDA and includes all the pertinent information regarding the District's current investments. Investment officers for the District will be present at the meeting to answer any questions about the report and the District's cash and investment position.

Submitted by: Jill Ludwig, CPA, RTSBA, Chief Financial Officer
Yvonne Dawson, Director of Budget and Treasury
Michele Reynolds, Director of Finance

Recommended for approval:



Dr. Thomas Randle
Superintendent

**Lamar Consolidated Independent School District
Quarterly Report of Investment Activity
for the quarter ending November 30, 2017**

Preface

House Bill 2459 amended the section of the Education Code that dealt with the investment of school district funds. Code Section 2256.023 as amended requires that the Investment Officer of the District prepare and submit to the Board of Trustees a report of investment activity and position on a quarterly basis. The attached report complies, to the best of our knowledge and ability, with the requirements, and covers the period September 1, 2017 through November 30, 2017.

Investment Strategy by Fund

GENERAL FUND STRATEGY:

Investments purchased will be limited to those authorized by the District's investment policy, Board Policy CDA (Legal) and CDA (Local), and be diversified by security type and institution. To the extent possible, the District will attempt to match its investments with anticipated cash flow requirements. Investments may be made in short term securities to maintain appropriate liquidity levels, avoid market risk, and generate superior returns during periods of rising interest rates. The District will limit its maximum stated maturities to one year, unless specific authority to exceed is given by the Board of Trustees (prior to purchase). The District will determine what the appropriate average weighted maturity of the portfolio should be based on the surrounding economic climate. This determination will be made on a periodic basis, by analysis of economic data, at least annually. Investments should be purchased with the intent of holding until maturity.

Reserve funds may be invested in securities exceeding one year if the maturity of such investments is made to coincide with the expected use of the funds. The ability to invest these types of funds should be disclosed to the Board of Trustees, including appropriate time restrictions, if any exist.

DEBT SERVICE FUND STRATEGY:

The investment strategy for the Debt Service Fund is the same as that for the General Fund above, with the following exceptions. The weighted average maturity of investments for the fund may be slightly greater due to the timing of disbursements. The greatest outflow of funds occurs in February and August of each year, when bond interest and/or principal is due. Based on published debt service schedules, investments purchased will mature prior to these obligations and need for funds. Other cash requirements will be considered prior to investment.

The District does not anticipate the existence of significant reserve funds for the Debt Service Fund.

CAPITAL PROJECTS FUND STRATEGY:

Generally, the investment strategy for the Capital Projects Fund is the same as that of the General Fund. The remaining bond proceeds are currently invested in Texpool, Lone Star, MBIA Texas CLASS, TexStar and Texas Term Daily Fund Investment Pools. The yield on the funds varies with the rates for the pools as a whole. As required by law, the District will monitor the investment earnings on the bond proceeds and comply with federal arbitrage regulations.

FOOD SERVICE, WORKMEN'S COMPENSATION, HEALTH INSURANCE TRUST, AND TRUST AND AGENCY FUNDS STRATEGY:

The investment strategy for each of these funds is the same as that of the General Fund.

INVESTMENT POSITION AT NOVEMBER 30, 2017

Securities are purchased to maximize the investment earnings of the District's portfolio and to minimize idle cash balances in demand deposit accounts at the depository bank, while maintaining the liquidity required to meet currently maturing obligations such as payroll and scheduled payments for accounts payable and bonded indebtedness.

The attached report provides details of ending cash and investment balances for each of the past three months and interest earned.

COST TO FAIR MARKET VALUE COMPARISON

The cost to fair market value comparison follows in a separate section. All investable funds were deposited with authorized investment pools as of November 30, 2017. Pertinent details at November 30, 2017 of each pool in which the District had funds invested follows:

<u>POOL NAME</u>	<u>NET ASSET VALUE %</u>	<u>BOOK VALUE OF POOL</u>	<u>MARKET VALUE OF POOL</u>	<u>LCISD % OF POOL</u>
Texpool	1.00	\$14,991,999,061	\$14,990,655,038	0.4298%

The dollar weighted average maturity of the pool's portfolio for November 2017 was 33 days.

Lone Star, Government Overnight Fund	1.00	\$ 2,955,600,231	\$2,955,444,692	0.5829%
---	------	------------------	-----------------	---------

The dollar weighted average maturity of the portfolio for the Government Overnight Fund for November 2017 was 18 days.

<u>POOL NAME</u>	<u>NET ASSET VALUE %</u>	<u>BOOK VALUE OF POOL</u>	<u>MARKET VALUE OF POOL</u>	<u>LCISD % OF POOL</u>
MBIA, Texas CLASS	1.00	\$5,210,595,858	\$5,210,663,520	0.9593%

The dollar weighted average maturity of the portfolio for Texas CLASS Fund for November 2017 was 52 days.

Texas Term, Daily Fund	1.00	\$1,760,846,690	\$1,760,720,685	2.4943%
---------------------------	------	-----------------	-----------------	---------

The dollar weighted average maturity of the portfolio for TEXAS TERM/DAILY Fund for November 2017 was 51.2 days.

TexStar,	1.00	\$6,157,485,043	\$6,157,068,439	1.2391%
----------	------	-----------------	-----------------	---------

The dollar weighted average maturity of the portfolio for TEXSTAR Fund for November 2017 was 32 days.

This report includes all information required by law to be presented to the Board of Trustees on a quarterly basis. We will be pleased to present additional information in this report in the future, if requested. The District's portfolio and investment management strategy is simple and conservative, which facilitates presentation of the required information.

We hereby certify that this report is a true and accurate description of the investment portfolio of the Lamar Consolidated Independent School District for the period ending November 30, 2017. This report fully discloses all material aspects of the District's cash and investment position for the quarter then ended. All investments are in compliance with the Public Funds Investment Act (HB 2459) and local investment policy.

Submitted by:

 Jill Ludwig,
 Chief Financial Officer

Date: 1/10/18

 Yvonne Dawson
 Director of Budget & Treasury

Date: 1/10/18

 Michele Reynolds
 Director of Finance

Date: 1/10/18

LAMAR CONSOLIDATED INDEPENDENT SCHOOL DISTRICT

QUARTERLY CASH BALANCE AND INVESTMENT REPORT FOR THE PERIOD ENDING NOVEMBER 30, 2017

	<u>09/30/2017</u>	<u>10/31/2017</u>	<u>11/30/2017</u>
<u>DEMAND DEPOSIT ACCOUNT BALANCES¹</u>			
General Fund	542,990	1,941,300	1,848,507
Special Revenue Funds (Combined)	2,082,406	1,077,370	1,595,011
Debt Service Fund	675,403	676,887	674,837
Capital Projects Fund	1,294,839	1,281,152	1,259,942
Workmen's Compensation and Health Insurance Trust Funds	1,097,004	704,142	1,083,487
Trust and Agency Funds, excluding Student Activity Funds	33,570	33,570	33,570
Student Activity Funds	2,255,533	2,388,992	2,480,358
Total Demand Deposits/Cash on Hand	<u>7,981,745</u>	<u>8,103,413</u>	<u>8,975,712</u>

¹ Balances presented are reconciled balances per book and will differ slightly from actual cash balances reported in the monthly bank statements. Also, totals above include insignificant amounts of cash on hand.

LAMAR CONSOLIDATED INDEPENDENT SCHOOL DISTRICT

QUARTERLY CASH BALANCE AND INVESTMENT REPORT FOR THE PERIOD ENDING NOVEMBER 30, 2017

		<u>09/30/2017</u>	<u>10/31/2017</u>	<u>11/30/2017</u>
INVESTMENT POOLS*				
General Fund	Texpool	70,022,620	61,317,672	48,160,099
	Lone Star	2,645,808	2,648,110	2,650,384
	Texas CLASS	15,598,302	15,615,114	15,631,769
Food Service Fund	Texpool	2,537,167	2,539,390	2,541,583
	Lone Star	91,380	91,460	91,539
Debt Service Fund	Texpool	2,499,143	2,557,984	2,655,816
	Lone Star	1,903,595	1,905,251	1,906,887
	Texas CLASS	957,500	958,532	959,554
	Texas Term/Daily	136,114	136,235	136,357
	TexSTAR	3,332,899	3,335,866	3,338,798
Capital Projects Fund	Texpool	9,209,786	10,140,382	8,974,031
	Lone Star	17,541,275	14,458,947	11,850,118
	Texas CLASS	33,755,622	33,652,707	33,394,849
	Texas Term/Daily	43,706,001	43,744,865	43,784,104
	TexSTAR	72,827,637	72,892,472	72,956,549
Workmen's Compensation and Health Insurance Trust Funds	Texpool	483,202	960,690	2,016,592
	Lone Star	727,947	728,580	729,206
Special Revenue Funds	Texpool	53,764	53,811	53,857
Student Activity Funds	Texpool	37,274	37,307	37,339
Total Investment in Pools		<u>278,077,036</u>	<u>267,775,375</u>	<u>251,869,231</u>
Summary of Interest Earned by Month				
	Texpool	65,965	69,446	61,573
	Lone Star	20,224	18,491	14,930
	Texas CLASS	48,268	50,153	49,366
	TexSTAR	65,233	67,902	67,009
	Texas Term/Daily	36,980	38,985	39,362
Total Interest Earned from Investment Pools		<u>256,670</u>	<u>244,877</u>	<u>232,240</u>
Average Yield by Month				
	Texpool	1.02	1.03	1.05
	Lone Star	1.02	1.02	1.04
	Texas CLASS	1.26	1.27	1.30
	TexSTAR	1.04	1.05	1.07
	Texas Term/Daily	1.03	1.05	1.09

* See supplemental report attached for balances at November 30, 2017 and details of transactions.

LAMAR CONSOLIDATED INDEPENDENT SCHOOL DISTRICT
 DETAILS OF TRANSACTIONS FOR INVESTMENT POOLS

	09/01/2017	DEPOSITS	WITHDRAWALS	09/30/2017	DEPOSITS	WITHDRAWALS	10/31/2017	DEPOSITS	WITHDRAWALS	11/30/2017
General Fund										
		64,012,438	(16,877,528)	70,022,620	17,231,000	(25,935,948)	61,317,672	8,481,338	(21,638,911)	48,160,099
		2,643,598	-	2,645,808	2,302	-	2,648,110	2,274	-	2,650,384
		15,582,359	-	15,598,302	16,812	-	15,615,114	16,655	-	15,631,769
Food Service Fund										
		2,535,052	-	2,537,167	2,223	-	2,539,390	2,193	-	2,541,583
		91,304	-	91,380	80	-	91,460	79	-	91,539
Debt Service Fund										
		2,422,860	-	2,499,143	130,815	(71,974)	2,557,984	97,832	-	2,655,816
		1,902,005	-	1,903,595	1,656	-	1,905,251	1,636	-	1,906,887
		956,521	-	957,500	1,032	-	958,532	1,022	-	959,554
		135,999	-	136,114	121	-	136,235	122	-	136,357
		3,330,057	-	3,332,899	2,967	-	3,335,866	2,932	-	3,338,798
Capital Projects Fund										
		9,526,091	(324,108)	9,209,786	1,020,024	(89,428)	10,140,382	1,019,678	(2,186,029)	8,974,031
		18,978,317	(1,452,782)	17,541,275	13,820	(3,096,148)	14,458,947	10,315	(2,619,144)	11,850,118
		34,023,651	(299,376)	33,755,622	32,309	(135,224)	33,652,707	31,688	(289,746)	33,394,649
		43,669,135	-	43,706,001	38,864	-	43,744,865	39,239	-	43,784,104
		73,334,417	(569,171)	72,827,637	64,835	-	72,892,472	64,077	-	72,956,549
Workmen's Compensation and Health Insurance Trust Funds										
		2,392,036	(1,900,000)	493,202	2,467,488	(2,000,000)	960,690	2,465,902	(1,410,000)	2,016,592
		727,339	-	727,947	633	-	728,580	626	-	729,206
Special Revenue Funds										
		53,719	-	53,764	47	-	53,811	46	-	53,857
Student Activity Funds										
		37,243	-	37,274	33	-	37,307	32	-	37,339
Total Investment in Pools		276,354,141	(21,422,965)	278,077,036	21,027,061	(31,328,722)	267,775,375	12,237,686	(28,143,830)	251,869,231

**CONSIDER APPROVAL OF THE LAMAR CONSOLIDATED INDEPENDENT
SCHOOL DISTRICT COMPREHENSIVE ANNUAL FINANCIAL REPORT
FOR THE 2016 - 2017 YEAR**

RECOMMENDATION:

That the Board of Trustees consider approval of the Lamar Consolidated Independent School District Comprehensive Annual Financial Report for the 2016 - 2017 fiscal year as presented.

IMPACT/RATIONALE:

A draft of the Lamar CISD Comprehensive Annual Financial Report (CAFR) for the 2016-2017 fiscal year is enclosed for your review. This report is comprised of three sections. The introductory section includes district information and a letter of transmittal. The financial section includes the auditors' report, various financial reports and notes, and required supplementary information. The last section includes unaudited statistical trend data to better help the user of the financial statements to understand the economic conditions under which the District operates.

A representative of Whitley Penn, LLP will be present to comment on the Comprehensive Annual Financial Report and respond to any questions.

Submitted by: Jill Ludwig, CPA, RTSBA, Chief Financial Officer
Michele Reynolds, CPA, Director of Finance

Recommended for approval:



Dr. Thomas Randle
Superintendent

CONSIDER RATIFICATION OF FINANCIAL AND INVESTMENT REPORTS

RECOMMENDATION:

That the Board of Trustees ratify the Financial and Investment Reports as presented.

PROGRAM DESCRIPTION:

Financial reporting is intended to provide information useful for many purposes. The reporting function helps fulfill government's duty to be publicly accountable, as well as to help satisfy the needs of users who rely on the reports as an important source of information for decision making.

Financial reports and statements are the end products of the accounting process. You will find attached the following reports:

- Ratification of December 2017 Disbursements, all funds
 - List of disbursements for the month by type of expenditure
- Financial Reports
 - Year-to-Date Cash Receipts and Expenditures, General Fund only
 - Investment Report

Submitted by: Jill Ludwig, CPA, RTSBA, Chief Financial Officer
Michele Reynolds, CPA, Director of Finance

Recommended for ratification:

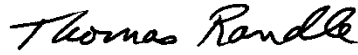
Dr. Thomas Randle
Superintendent

SCHEDULE OF NOVEMBER 2017 DISBURSEMENTS

IMPACT/RATIONALE:

All disbursements made by the Accounting Department are submitted to the Board of Trustees for ratification on a monthly basis. Disbursements made during the month of November total \$25,795,950 and are shown below by category:

<u>3-Digit Object</u>	<u>Description</u>	<u>Disbursements</u>
611/612	Salaries and Wages, All Personnel	16,843,733
614	Employee Benefits	832,700
621	Professional Services	3,870
623	Education Services Center	11,000
624	Contracted Maintenance and Repair Services	328,592
625	Utilities	794,551
626	Rentals and Operating Leases	17,075
629	Miscellaneous Contracted Services	529,590
631	Supplies and Materials for Maintenance and Operations	373,502
632	Textbooks and Other Reading Materials	743,504
633	Testing Materials	809
634	Food Service	339,052
639	General Supplies and Materials	897,653
641	Travel and Subsistence -- Employee and Student	92,053
642	Insurance and Bonding Costs	5,405
643	Election Expense	980
649	Miscellaneous Operating Costs/Fees and Dues	26,136
659	Other Debt Services Fees	2,050
662	Building Purchase, Construction, and/or Improvements	3,868,667
663	Furniture & Equipment - \$5,000 or more per unit cost	72,528
131	Inventory Purchases	7,965
217	Operating Transfers, Loans and Reimbursements	848
573/575/592	Miscellaneous Refunds/Reimbursements to Campuses	3,687
	Total	25,795,950

PROGRAM DESCRIPTION:

The report above represents all expenditures made during the month of November 2017. The detailed check information is available upon request.

Submitted by,

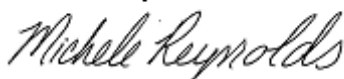

Michele Reynolds,
Director of Finance

Recommended for approval:

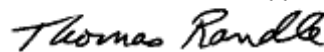

Dr. Thomas Randle
Superintendent

**LAMAR CONSOLIDATED I.S.D.
GENERAL FUND
YEAR TO DATE CASH RECEIPTS AND EXPENDITURES
(BUDGET AND ACTUAL)
AS OF DECEMBER 31, 2017**

CASH RECEIPTS	AMENDED BUDGET	ACTUAL	BUDGET VARIANCE	PERCENT ACTUAL/ BUDGET
5700-LOCAL REVENUES	163,404,252.00	85,143,317.00	(78,260,935.00)	52.1%
5800-STATE PROGRAM REVENUES	99,718,336.00	41,910,063.00	(57,808,273.00)	42.0%
5900-FEDERAL PROGRAM REVENUES	2,925,000.00	686,193.00	(2,238,807.00)	23.5%
TOTAL- REVENUES	266,047,588.00	127,739,573.00	(138,308,015.00)	48.0%
EXPENDITURES				
6100-PAYROLL COSTS	221,523,369.00	72,798,690.00	148,724,679.00	32.9%
6200-PROFESSIONAL/CONTRACTED SVCS.	24,847,564.00	7,205,859.00	17,641,705.00	29.0%
6300-SUPPLIES AND MATERIALS	13,571,160.00	3,592,539.00	9,978,621.00	26.5%
6400-OTHER OPERATING EXPENDITURES	5,698,460.00	1,158,393.00	4,540,067.00	20.3%
6600-CAPITAL OUTLAY	3,739,379.00	978,224.00	2,761,155.00	26.2%
TOTAL-EXPENDITURES	269,379,932.00	85,733,705.00	183,646,227.00	31.8%

Lamar CISD
Local Investment Pools
as of December 31, 2017

ACCOUNT NAME	BEGINNING BALANCE	TOTAL DEPOSIT	TOTAL WITHDRAWAL	TOTAL INTEREST	MONTH END BALANCE
TexPool accounts are as follows:					
Food Service	2,541,583.21	0.00	0.00	2,539.39	2,544,122.60
General Account	47,191,299.52	0.00	19,983,231.66	38,860.98	27,246,928.84
Health Insurance	1,684,435.41	1,194,898.33	1,900,000.00	1,916.04	981,249.78
Workmen's Comp	332,157.17	38,333.33	40,000.00	350.41	330,840.91
Property Tax	797,462.41	42,057,832.98	0.00	14,029.60	42,869,324.99
Vending Contract Sponsor	480,941.01	0.00	0.00	480.51	481,421.52
Deferred Compensation	2.55	0.00	0.00	0.00	2.55
Debt Service Series 2007	5,166.55	0.00	0.00	5.18	5,171.73
Capital Projects Series 2005	230,424.85	0.00	0.00	230.19	230,655.04
Student Activity Funds	37,337.22	0.00	0.00	37.33	37,374.55
Taylor Ray Donation Account	54.72	0.00	0.00	0.00	54.72
Capital Projects Series 2007	211,564.72	0.00	0.00	211.39	211,776.11
Common Threads Donation	53,856.97	0.00	0.00	53.81	53,910.78
Debt Service Series 2008	4,365.87	0.00	0.00	4.36	4,370.23
Debt Service 2012A	10,761.63	0.00	0.00	10.78	10,772.41
Debt Service 2012B	7,478.52	0.00	0.00	7.47	7,485.99
Debt Service 2014A	3,500.64	0.00	0.00	3.45	3,504.09
Debt Service 2014B	8,707.84	0.00	0.00	8.76	8,716.60
Debt Service 2013	4,337.39	0.00	0.00	4.36	4,341.75
Debt Service 2013A	77,776.93	0.00	0.00	77.75	77,854.68
Debt Service 2015	15,079.55	0.00	0.00	15.07	15,094.62
Capital Projects 2015	155,924.37	0.00	0.00	155.74	156,080.11
Debt Service 2016A	6,988.70	0.00	0.00	6.99	6,995.69
Debt Service 2016B	1,839.12	0.00	0.00	1.77	1,840.89
Debt Service 2017	175,868.79	0.00	0.00	175.74	176,044.53
Debt Service 2017 Capitalized Interest	2,024,284.60	0.00	0.00	2,022.55	2,026,307.15
Capital Projects 2017	8,376,117.10	0.00	4,274,424.72	4,180.70	4,105,873.08
Lone Star Investment Pool Government Overnight Fund					
Capital Projects Fund	5,079.06	0.00	0.00	5.04	5,084.10
Workers' Comp	729,206.37	0.00	0.00	723.42	729,929.79
Property Tax Fund	32,532.12	0.00	0.00	32.27	32,564.39
General Fund	2,617,852.24	0.00	0.00	2,597.08	2,620,449.32
Food Service Fund	91,538.71	0.00	0.00	90.81	91,629.52
Debt Service Series 1996	0.01	0.00	0.00	0.00	0.01
Capital Project Series 1998	708.75	0.00	0.00	0.70	709.45
Debt Service Series 1990	0.04	0.00	0.00	0.00	0.04
Debt Service Series 1999	2.43	0.00	0.00	0.00	2.43
Capital Project Series 1999	0.01	0.00	0.00	0.00	0.01
Capital Projects 2007	388.52	0.00	0.00	0.39	388.91
Capital Projects 2008	0.31	0.00	0.00	0.00	0.31
Capital Projects 2012A	43.37	0.00	0.00	0.04	43.41
Capital Projects 2014B	17.21	0.00	0.00	0.02	17.23
Capital Projects 2015	2,159,413.40	0.00	0.00	2,142.28	2,161,555.68
Debt Service Series 2015	1,906,882.34	0.00	0.00	1,891.75	1,908,774.09
Capital Projects 2017	9,684,467.97	0.00	0.00	9,607.64	9,694,075.61
MBIA Texas CLASS Fund					
General Account	15,631,769.50	0.00	0.00	18,631.22	15,650,400.72
Capital Project Series 1998	921.37	0.00	0.00	1.10	922.47
Capital Projects Series 2007	1.00	0.00	0.00	0.00	1.00
Debt Service Series 2007	1.00	0.00	0.00	0.00	1.00
Capital Projects Series 2012A	8,227,041.72	0.00	666,472.85	9,412.55	7,569,981.42
Debt Service 2015	959,552.66	0.00	0.00	1,143.69	960,696.35
Capital Projects 2017	25,166,684.99	0.00	0.00	25,212.09	25,191,897.08
TEXSTAR					
Capital Projects Series 2007	751.65	0.00	0.00	0.73	752.38
Debt Service Series 2008	13.86	0.00	0.00	0.00	13.86
Capital Projects Series 2008	979,740.09	0.00	0.00	978.75	980,718.84
Debt Service Series 2012A	40.45	0.00	0.00	0.01	40.46
Debt Service Series 2012B	1.64	0.00	0.00	0.00	1.64
Capital Projects Series 2012A	12.21	0.00	0.00	0.00	12.21
Debt Service 2013	2.67	0.00	0.00	0.00	2.67
Capital Projects 2014A	0.74	0.00	0.00	0.00	0.74
Capital Projects 2014B	2.65	0.00	0.00	0.00	2.65
Debt Service 2015	3,338,741.55	0.00	0.00	3,335.38	3,342,076.93
Capital Projects 2015	46,866,265.00	0.00	6,130,259.42	43,417.41	40,779,422.99
Capital Projects 2017	25,109,776.34	0.00	0.00	25,084.47	25,134,860.81
TEXAS TERM/DAILY Fund					
Capital Projects Series 2007	1,017,744.77	0.00	0.00	1,048.89	1,018,793.66
Capital Projects Series 2008	142.54	0.00	0.00	0.15	142.69
Capital Projects Series 2012A	57.23	0.00	0.00	0.06	57.29
Capital Projects Series 2014A	0.32	0.00	0.00	0.00	0.32
Capital Projects Series 2014B	2,258,574.75	0.00	0.00	2,327.68	2,260,902.43
Debt Service 2015	136,356.45	0.00	0.00	140.53	136,496.98
Capital Projects 2015	15,339,695.64	0.00	0.00	15,809.05	15,355,504.69
Capital Projects 2017	25,167,889.17	0.00	0.00	25,937.97	25,193,827.14

ACCOUNT TYPE	AVG. RATE OF RETURN	CURRENT MONTH EARNINGS
TEXPOOL ACCOUNT INTEREST	1.18	\$65,390.32
LONE STAR ACCOUNT INTEREST	1.17	\$17,091.44
MBIA TEXAS CLASS ACCOUNT INTEREST	1.41	\$54,400.65
TEXSTAR ACCOUNT INTEREST	1.18	\$72,816.75
TEXAS TERM/DAILY ACCOUNT INTEREST	1.21	\$45,264.33
TOTAL CURRENT MONTH EARNINGS		\$254,963.49
EARNINGS 9-01-17 THRU 11-30-17		\$713,786.20
TOTAL CURRENT SCHOOL YEAR EARNINGS		\$968,749.69

**CONSIDER APPROVAL OF PURCHASE OF
BAND AND ORCHESTRA INSTRUMENTS, EQUIPMENT, RELATED ITEMS AND SERVICES**

RECOMMENDATION:

That the Board of Trustees approve all vendors who responded to the proposal for band and orchestra instruments, equipment, related items and services for the District.

IMPACT/RATIONALE:

RFP 02-2018RL requested catalog pricing discounts to purchase new or refurbished musical instruments and equipment, sheet music, related items and services for use in the District's Secondary Fine Arts programs. This type of award is beneficial to the District because it allows the Fine Arts Department a wide variety of items to select from, while ensuring that the District is compliant with purchasing regulations according to TEC 44.031 and federal procurement guidelines as per the Education Department General Administrative Regulations (EDGAR).

PROGRAM DESCRIPTION:

The intent of this proposal is to establish a discount percentage off catalog or published list prices for each of the categories of items specific to Fine Arts musical instrument parts and supplies. The categories included in the bid are:

New Instruments
Music Equipment
Music Supplies

Sheet Music
Refurbished Instruments
Repair Work

The Director of Fine Arts worked with the Purchasing Department on bid specifications, evaluation, and award recommendation.

Vendors will be utilized for the diverse fine arts needs across the district. The contracts will be awarded for one year with 4 automatic one-year renewal options. Either party may provide a 30-day advance written notice of intent to cancel prior to the annual termination.

The procurement shall commence upon board approval. Purchases will be requested by individual campuses or district groups utilizing local and federal funds.

Submitted by: Jill Ludwig, CPA, RTSBA, Chief Financial Officer
Lamanda Nipps, CTSBO, Purchasing & Materials Manager
Ram Estrada, Director of Fine Arts

Recommended for approval:



Dr. Thomas Randle
Superintendent

**RFP 02-2018RL BAND AND ORCHESTRA INSTRUMENTS, EQUIPMENT, RELATED ITEMS
AND SERVICES**

1. AMC Music
2. Aves Audio Visual System
3. Collins Music Center
4. Duquette Piano Service
5. Fleming Instrument
6. Fort Bend Music
7. J.W. Pepper & Son
8. Katy Violin Shop
9. K. D. Music & Arts
10. Lisle Violin Shop
11. Loan Star Percussion
12. Pender's Music
13. Peripole Inc.
14. Romeo Music
15. Sam Ash Music
16. Shar Music
17. Steve Weiss Music
18. Sweetwater Sound
19. Taylor Music
20. Terra Nova Violins
21. Tote Unlimited
22. Washington Music
23. Wenger Corporation
24. Woodwinds & Brasswind, Inc

CONSIDER APPROVAL OF CATERING AND BANQUET SERVICES

RECOMMENDATION:

That the Board of Trustees approve all vendors who responded to the proposal for catering and banquet services for the District.

IMPACT/RATIONALE:

Purchases may be made for food and catering services by each campus or department. This type of award is beneficial to the District as it allows our campuses and departments a variety of vendors to select from, while ensuring that the District is compliant with purchasing regulations according to TEC 44.031 and EDGAR.

PROGRAM DESCRIPTION:

RFP 01-2018RL requested that vendors supply detailed menus with discounted pricing specific to LCISD. In addition, vendors provided ordering instructions and delivery options for LCISD locations. Vendor-discounted menus provide Lamar CISD staff the benefit of budgeting and overall planning for food expenses.

The RFP was divided into two parts. Part I included catering and banquet services utilized for all administrative events and functions. Working with the Purchasing Department, various department staff (who are familiar with the ordering of catering and banquet services) evaluated submissions based on an 8-criteria rubric. After evaluation of the businesses who responded to Part I, it is recommended that the award be made to all respondents. Part II of the procurement effort included catered foods served to students in Lamar CISD cafeterias. This section requires vendors to meet National School Nutrition Standards. Vendors that indicated interest in Part II provided the nutritional ingredients of their products as part of their response. The Purchasing and Food Service Departments evaluated all responses for compliance with federal guidelines. Having met the federal nutrition requirements, the vendor recommended for award is Chick-fil-a.

This proposal will be awarded as one-year term contract. Either party may provide a 30-day advance written notice of intent to cancel prior to the annual termination. Upon approval, the agreement will commence on January 17, 2018.

Submitted by: Jill Ludwig, CPA, RTSBA, Chief Financial Officer
 Matt Antignolo, Director Food Services
 Lamanda Nipps, RTSBA, Purchasing & Materials Manager

Recommended for approval:



Dr. Thomas Randle
Superintendent

RFP 01-2018RL CATERING AND BANQUET SERVICES

Part I – For administrative events & function use

1. Alonti Café & Catering
2. Ben's Chuck Wagon
3. Chick-Fil-A (Greatwood & Rosenberg)
4. Clancy Public House
5. Dish Society
6. Double Dave's Pizza
7. Firehouse Subs
8. Gringo's Mexican Kitchen
9. IL Primo Pizza
10. Italian Maid Café
11. Jersey Mikes
12. La Cocina
13. Lone Star Kolache (Katy)
14. Mama Fu's Asian House
15. McAlister's
16. Mr. C's Homestyle Catering
17. M & M's Kitchen
18. Old Main Street Bakery
19. Panera Bread
20. Russo's (Greatwood New York Pizza)
21. Papa John's (Rosenberg)
22. Pepperoni's Pizza
23. Safari Texas
24. Schulze's BBQ
25. Skeeters (Sugar Land)
26. Southern Ice Cream
27. The Burger Barn
28. The Swinging Door
29. The Western Steakhouse
30. Whole Foods
31. Witt's BBQ
32. Vincek's Smokehouse

Part II – For LCISD cafeteria use

1. Chick-fil-a (Greatwood & Rosenberg)

CONSIDER APPROVAL OF BOARD CALENDAR FOR 2018

RECOMMENDATION:

That the Board of Trustees approve the proposed Board Calendar for 2018.

IMPACT/RATIONALE:

The Board of Trustees has major responsibilities and activities at certain times during the year. This calendar outlines a timeline for when these major responsibilities and activities should occur. Upon approval, this calendar will be followed unless the Board President and Superintendent agree upon changes.

Recommended for approval:



Dr. Thomas Randle
Superintendent

**LAMAR CONSOLIDATED INDEPENDENT SCHOOL DISTRICT
BOARD CALENDAR
2018**

January	Audit Report Hearing on AEIS Report Superintendent's Evaluation
February	School Calendar
March	Administrative Contracts
April	Employee Contracts
June	Graduations Budget Workshop
July	Superintendent's Formative Conference Review District Goals Budget Workshop
August	Budget Workshop Public Hearing on Budget Budget Adoption for 2018 – 2019 Teacher Appraisal Calendar Current Year Final Budget Amendments Public Hearing on Tax Rate Adoption of Tax Rate for 2018
September	District Improvement Plans Campus Improvement Plans School FIRST Report
October	Board/Superintendent Team Building

**CONSIDER APPROVAL OF RESOLUTION PROCLAIMING
BLACK HISTORY MONTH**

RECOMMENDATION:

That the Board of Trustees approve the attached resolution proclaiming February 2018 as “Black History Month” in the Lamar Consolidated Independent School District.

IMPACT/RATIONALE:

National Black History Month is celebrated during February each year to recognize the rich heritage and significant contributions of African-Americans, both past and present.

Lamar CISD schools plan a wide variety of special activities to observe Black History Month during February.

Submitted by: Mike Rockwood, Executive Director of Community Relations

Approved by:



Dr. Thomas Randle
Superintendent

Resolution

WHEREAS, Black History Month is celebrated throughout the United States during the month of February; and

WHEREAS, Black History Month recognizes the rich heritage and significant contributions to our lives by African-Americans; and

WHEREAS, schools are in a unique position to share an appreciation of the heritage and accomplishments of African-Americans among children from all races and backgrounds; and

WHEREAS, Lamar CISD schools commemorate Black History Month with special activities and observances;

NOW, THEREFORE, BE IT RESOLVED that the Trustees of the Lamar Consolidated Independent School District declare February 2018 as Black History Month in the Lamar Consolidated Independent School District and encourage members of our community to share in this celebration of American heritage.

Adopted this 16th day of January, 2018.

James Steenbergen, President

Kay Danziger, Secretary



**CONSIDER APPROVAL OF RESOLUTION PROCLAIMING
CAREER AND TECHNICAL EDUCATION MONTH**

RECOMMENDATION:

That the Board of Trustees approve the attached resolution proclaiming February 2018 as “Career and Technical Education Month” in the Lamar Consolidated Independent School District.

IMPACT/RATIONALE:

The growing Texas population is becoming less rural, more global and more diverse. Our students need to be aware of, and prepared for, all opportunities in the work place. Specialized training is imperative. The knowledge necessary for a skilled-labor force in Texas starts with Career and Technical Education (CTE) at the secondary level.

Knowing that CTE plays a critical role in student development, proclaiming February 2018 as “Career and Technical Education Month” will provide the community with a clear statement that CTE is valued and very important in the Lamar CISD.

PROGRAM DESCRIPTION:

From a beginning with a limited number of vocational training programs, CTE has evolved into a broad system encompassing a variety of challenging fields. CTE features diverse subjects that are constantly evolving due to a changing global economy. Today’s CTE provides students:

- Academic subject matter taught with a relevance to the real world;
- Employability skills, from job-related abilities to workplace ethics;
- Career pathways that link secondary and post-secondary education; and
- Education for training related to workplace training, skill upgrades and career advancement.

For the fall of 2017, Lamar CISD had approximately 8,412 students participating in CTE courses from grades 7-12.

Submitted by: Joel Garrett, Director, Career and Technical Education
 Leslie Haack, Executive Director of Secondary Education

Recommended for approval:

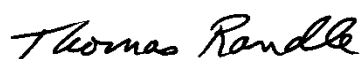

Dr. Thomas Randle
Superintendent

Resolution

WHEREAS, the Association for Career and Technical Education has designated February 1-28, 2018 as **Career and Technical Education Month**; and

WHEREAS, profound economic and technological changes in our society are reflected in the structure and nature of work, placing new and additional responsibilities on our educational system; and

WHEREAS, career and technical education provides a career connection and is the backbone of a strong, well-educated workforce, which fosters productivity in business and industry and contributes to America's leadership in the international marketplace; and

WHEREAS, career and technical education gives high school students experience in practical, meaningful applications of skills such as reading, writing and mathematics, improving the quality of their education, motivating potential dropouts and giving all students leadership opportunities; and

WHEREAS, the ever-increasing cooperative efforts of career and technical educators, business and industry stimulate the growth and vitality of our local economy and that of the entire nation by preparing graduates for careers that are expected to experience the largest and fastest growth in the next decade;

THEREFORE, be it resolved, that the Board of Trustees of the Lamar Consolidated Independent School District declare February 1-28, 2018 as **Career and Technical Education Month** and urge all citizens to become familiar with the services and benefits offered by career and technical education programs and to support these programs to enhance work skills and productivity.

Adopted this 16th day of January, 2018.

James Steenberg, President

Kay Danziger, Secretary

**CONSIDER APPROVAL OF RESOLUTION PROCLAIMING
SCHOOL COUNSELOR SCHOOL WEEK**

RECOMMENDATION:

That the Board of Trustees approve the attached resolution proclaiming the week of February 5 – 9, 2018 as "School Counselor Week" in the Lamar Consolidated Independent School District.

IMPACT/RATIONALE:

Professional counselors are valuable members of the educational teams in schools. They contribute to the development of children through guidance, counseling, consultation, coordination, assessment and program management.

School counselors also work with parents, teachers, administrators and the community to optimize student learning. They are important resource persons in understanding and responding to student behavior.

School counselors respond daily to crises in students' lives. These crises include issues such as suicide, abuse, drug and alcohol use, pregnancy and family problems.

Submitted by: Mike Rockwood, Executive Director of Community Relations

Approved by:



Dr. Thomas Randle
Superintendent

Resolution

WHEREAS, School Counselors help students in public schools reach their full potential; and

WHEREAS, School Counselors are committed to helping students explore their abilities, strengths, interests and talents as these traits relate to career awareness and development; and

WHEREAS, School Counselors help parents focus on ways to further the educational, personal and social growth of their children; and

WHEREAS, School Counselors work with teachers and other educators to help students explore their potential and set realistic goals for themselves; and

WHEREAS, School Counselors identify and utilize community resources that enhance and supplement comprehensive school counseling programs and help students become productive members of society.

NOW THEREFORE, BE IT RESOLVED that the Trustees of the Lamar Consolidated Independent School District recognize the importance of school counseling programs, which are an integral part of the educational process that enables all students to achieve success in school and declare the week of February 5 – 9, 2018 as School Counselor Week in the Lamar Consolidated Independent School District.

Adopted this 16th day of January, 2018.

James Steenbergen, President

Kay Danziger, Secretary

**CONSIDER APPROVAL OF AMENDMENT TO THE TEXAS GENERAL LAND
OFFICE AGREEMENT FOR THE EMERGENCY INTERRUPTIBLE LOAD
SERVICE PROGRAM**

RECOMMENDATION:

That the Board of Trustees approve the emergency interruptible load service program agreement with Links EP, LLC., through The Texas General Land Office.

IMPACT/RATIONALE:

The Electric Reliability Council of Texas (ERCOT) encourages customer participation to address the increasing need for electricity and infrastructure limitations. To address this need ERCOT created the program called “Demand Response”. This is an opportunity to get paid to reduce electricity usage when ERCOT needs to reduce demand because of operational conditions. By doing so, this will help to prevent grid failure, and get paid by ERCOT for being a stand-by resource. ERCOT will pay the district even if we are not asked to curtail.

PROGRAM DESCRIPTION:

Upon approval Links EP, LLC will continue Lamar CISD’s enrollment in the Demand Response Program.

Submitted by: Kevin McKeever, Administrator for Operations
Aaron Morgan, Region 4

Recommended for approval:



Dr. Thomas Randle
Superintendent

Exhibit F - LINKS EP DEMAND RESPONSE

DEMAND RESPONSE SERVICES: Customer (as defined below) wishes to participate in Program(s) and to retain Seller to arrange for participation in the Programs described below and in the Demand Response Services Attachment DR-1 attached hereto (the “Services”). The Parties acknowledge that Seller and Customer will utilize Links EP, LLC (“Seller’s Representative”) for fulfillment of certain obligations as outlined in this Exhibit (as defined below).

TERM: This Exhibit is attached to and made a part of the Retail Sales Interlocal Agreement dated February 1, 2018 between Seller and Customer (the “Master Agreement”) and will become effective on the date it is signed by both Parties (the “Effective Date”). The initial term of this Exhibit shall commence on the Effective Date and continue for a period of 36 Months from the Effective Date, unless earlier terminated by either Party pursuant to the terms herein (“Initial Term”). This Exhibit shall automatically renew on a month-to-month basis (the “Renewal Period”) upon the expiration of the Initial Term, unless at least sixty (60) days prior to the expiration of the Term (as it may have been renewed), either Party provides written notice of termination to the other Party. The Initial Term, together with any Renewal Period(s) is referred to herein as the “Term”. The expiration or termination of this Exhibit shall not affect any Program (as defined below) or affect or excuse the performance by either Party of obligations of any Program awards or pending bids, including Customer load participation, payment awards, pending bids, which existed prior to the date of such termination or expiration, or that by their nature survive such expiration or termination. This Exhibit shall continue in effect with respect to any such Attachment DR-1 or related exhibits entered into hereunder prior to the end of the Term and in each case, until the Parties have fulfilled all obligations with respect to such Participating Loads (as defined below).

CUSTOMER ACKNOWLEDGEMENT: Customer acknowledges that Seller exercises no independent control over the equipment necessary to provide either demand response services or standby generation, or for any associated payments thereof. Customer recognizes that Seller will have no liability or responsibility for the failure of either demand response or standby generation equipment to perform as required in order to fulfill the services requested by Customer.

ASSIGNMENT TO CAVALLO: Notwithstanding anything to the contrary in the this Exhibit or the Master Agreement, if, subsequent to the date of this Exhibit, Seller (1) is prohibited by law from providing or otherwise arranging demand response or standby generation services to Customer, or (2) is in default under this Exhibit, Seller, Customer and Cavallo (as defined below) agree that Cavallo will provide or arrange for demand response and/or standby generation services directly to Customer pursuant to the terms and conditions contained in this Exhibit and Attachment DR-1 as applicable. In this event, Customer shall be conclusively deemed to have incurred no actual damages.

DEFINITIONS:

As used herein, the following terms shall have the meanings set forth below:

“Exhibit F” means this Demand Response Exhibit and all exhibits and attachments attached hereto.

“Cavallo” means Cavallo Energy Texas LLC, a Texas limited liability company

“Curtailed Event” means a test or an event requiring either the reduction of participating load, the injection of generator power, or both, which can be initiated during a Program by Seller’s Representative, ERCOT or the TDU as appropriate.

“Customer” means the “Customer”, and its authorized facilities, as identified in the Master Agreement.

“ERCOT Protocols and PUC Rules” means all protocols and procedures, including those commonly known as the ERCOT Nodal Protocols as adopted by ERCOT, and the applicable rules and regulations of the PUC, in each case as may be amended from time to time.

“ERS” means ERCOT’s emergency response service used to assist in maintaining or restoring ERCOT’s system.

“ERS Capacity” means the amount of retail electricity consumption that Customer is capable of interrupting or curtailing in accordance with ERCOT or TDU requirements.

“ERS Management Services” means services to qualify, schedule, bid, deploy, and settle with ERCOT for the purposes of offering Customer’s load interruption capacity for ERS consistent with ERS Protocols and PUC Rules.

“ERS Resource” means either a generator contracted to provide ERS by injecting energy to ERCOT’s system, or an end-user’s load contracted to provide ERS by removing demand from ERCOT’s system.

“Links EP System” means Links EP equipment, software, Links Energy Portal, and communications to monitor onsite energy information and remotely activate participating sites.

“Master Agreement” shall have the meaning set forth in the Section entitled “Term” above.

“Participating Load” means Customer’s demand response capacity that is contracted into a Program.

“Party” or “Parties” means, individually or collectively, the parties to this Exhibit.

“Program” means load curtailment programs including but not limited to ERS, , Load Acting as a Resource (“LaaR”), TDU sponsored programs, and load curtailment programs of Seller designed to help Customer reduce capacity-related TDU costs and/or to receive or avoid high prices in real-time or day-ahead markets.

“Prudent Industry Practices” means practices, methods and acts engaged in or approved by a significant portion of the power procurement and scheduling industry which, in the exercise of reasonable judgment at the time the decision was made, would reasonably have been expected to achieve desired results consistent with good business practices, reliability criteria, safety considerations and expediency; provided, however, that Prudent Industry Practices is not limited to any particular practice, but instead includes a range of acceptable practices methods and acts.

“Seller” means the Texas General Land Office.

“Seller’s Representative” means Links EP, LLC.

“Services” shall have the meaning set forth in the Section entitled “Demand Response Services” above.

“Tax” or “Taxes” means any income, gross receipts, profits, capital stock or duty, franchise, withholding, payroll, social security, workers compensation, unemployment, disability, property, ad valorem, stamp, excise, severance, occupation, service, sales, use, license, lease, transfer, import, export, value added, alternative minimum, estimated or other similar tax (including any fee, assessment, or other charge in the nature of or in lieu of any tax) imposed by any Tax Authority, and any interest, penalties, or additional amounts in respect of the foregoing.

“Tax Authority” means, with respect to any Tax, the governmental entity or political subdivision thereof that imposes such Tax, and the agency (if any) charged with the collection of such Tax for such governmental entity or political subdivision, including the Internal Revenue Service.

“Term” shall have the meaning set forth in the Section entitled “Term” above.

SITE

- 1) **Site Qualification.** Seller, or Seller’s Representative, shall:
 - a) collect from the Customer certain preliminary information about Customer’s ERS Capacity. Required preliminary information may include service address, ESI ID, primary purpose of loads behind meter, data regarding on-site generation, if any, and letter of authorization to collect usage and load information from

the TDU, and

- b) request historical usage data from the TDU, and
- c) analyze historical data to assess minimum curtailable load, to pre-qualify for each Program, and evaluate economics for Links EP System installation.

2) **Site Commitment.**

- a) Seller or Seller's Representative shall present ERS Capacity and Program recommendations to the Customer, and, if accepted by the Customer, such recommendations shall be documented in Attachment DR-1, and such capacity, once accepted by ERCOT or the TDU, shall become a Participating Load under this Exhibit.

3) **Site Enablement.**

- a) For each Participating Load, Seller's Representative shall install, operate, test and maintain Links EP System.
- b) Seller's Representative shall assist Customer with the process of qualifying its sites to offer demand response capacity through coordination, documentation, communications and testing.
- c) Seller's Representative shall undertake reasonable action to enroll fully qualified Participating Loads into appropriate Programs as authorized by Customer.

4) **Operation.**

- a) Seller's Representative shall provide enrollment, scheduling and load management for Participating Loads as appropriate for each Program under Attachment DR-1.
- b) Seller's Representative, in compliance with the rules of each Program, will coordinate Program provider calls through an information control center and will notify Customer of any demand response event or test initiation and again when each event or test has been terminated. Seller's Representative will provide updates to Customer as Program rule changes are implemented by the Program provider that affect operations or revenues.
- c) Seller's Representative shall verify settlement calculations and payments as applicable, and confirm such calculations with Customer's bookkeeper.
- d) Seller's Representative shall remit payments to the Customer as set forth in this Exhibit and related Attachment DR-1

5) **Links Energy Portal**

- a) Seller's Representative shall provide a secure web-based energy management application for Customer to access data on demand response Programs, curtailment events, and Participating Loads.
- b) Seller's Representative hereby grants to Customer and its designated number of authorized users, for the term of the Exhibit, a non-exclusive, non-assignable right and license to the Links EP System.
- c) The Parties agree that Seller's Representative shall own all right, title, and interest in Seller's Representative's portal (but not in Seller's portal) and any modification, enhancement, extension, or derivative work to the Seller's Representative portal. Intellectual property rights includes all hardware, software, design, and integration along with the look and feel of the portal. Performance of Services or this Exhibit does not in any way transfer ownership rights to the portal.

- d) All portal data and information is provided on an “as-is” and “as available” basis. Seller, and Seller’s Representative (i) make no express or implied representations, warranties, covenants as to the accuracy, completeness or relevance of the information, data, opinions, or comments or any direct or indirect recommendations included in providing the Services, or suggested by the data, and (ii) Customer should rely solely on its independent judgments, analysis, assumptions, estimates, studies, computations, experience and knowledge with respect to the Services or participation in the Programs.

RESPONSIBILITIES OF THE CUSTOMER

(a) Program Performance. Customer agrees to make commercially reasonable efforts to meet the performance requirements for the Services. Seller, or Seller’s Representative, will rely on Customer to provide accurate information including, but not limited to, that information needed by ERCOT in connection with the demand response management services rendered hereunder and needed by Seller to otherwise perform its obligations hereunder.

(b) Equipment. If applicable, Customer shall allow Seller, or its authorized representatives, subject to Customer prior approval in writing, to install the necessary support equipment and communications pursuant to Attachment B to participate in the Program(s). During the Term of this Agreement, Customer will not modify, tamper with or disconnect the meter, the communication equipment or any connections or interfaces to the meter or communication equipment.

(c) Change in Ability to Perform. Customer will inform Seller’s Representative immediately of any unplanned reduction or unavailability of its capacity to provide such demand response services and provide Seller’s Representative with written documentation of the reason for its inability to meet the requirements of the Program(s). Such conditions may include equipment failures, Force Majeure events or un-forecasted reductions in production.

(d) Exclusivity. Customer shall not enroll Participating Loads with a demand response provider other than Seller or Seller’s Representative, or concurrently enroll meters for any other Programs.

(e) Standby Generators. As applicable, Customer shall maintain, or shall arrange for maintenance by others of standby generators, switch gear and related equipment in good working order, if any, and shall remain in good standing in regards to any applicable federal, state or local environmental regulations, used to power a Participating Load during a Curtailment Event.

(f) Enablement. Customer has installed, or caused to be installed, and will maintain the necessary equipment, controls procedures, practices and training to ensure the safety of persons and property in the event of a curtailment event and subsequent restoration of electricity to any of its facilities participating in Programs under this Exhibit, and will comply with all applicable availability testing as required by the Program providers.

(g) Assignment of Remote Activation. Customer hereby assigns remote activation rights for Participating Loads to Seller or Seller’s Representative. Such assignment permits Seller or Seller’s Representative to remotely curtail load and activate generators, as applicable, and resume normal operations in response to dispatch orders for applicable Programs; provided, however, that neither Seller nor Seller’s Representative shall remotely operate Customer’s generator(s) for use in any Program while such generator is being used by Customer for emergency backup power purposes.

(h) Participating Load Curtailment. Customer authorizes Seller or Seller’s Representative to monitor and remotely activate applicable switches to reduce each Participating Load by its contracted capacity within the required timeframe under the rules for the applicable Program. Customer authorizes Seller or Seller’s Representative, as the controlling entity of the Participating Load, in conjunction with remotely controlling such Participating Load to comply with testing and curtailment rules for contracted loads as defined in Attachment DR-1.

(i) Seller’s Representative. Customer acknowledges that Seller has designated Seller’s Representative to fulfill certain obligations of Seller pursuant to this Exhibit. As evidenced by Customer’s acknowledgement of

Attachment DR-1, during the term of this Exhibit, Seller's Representative shall provide the Services for the benefit of Customer in accordance with Prudent Industry Practices and Attachment DR-1.

(j) Customer Contact Information. Customer shall provide Seller and Seller's Representative with up to date contact information during the term of this agreement as defined in Attachment A.

(k) Letter of Authorization for Installation of Pulse Equipment. As required to effectuate performance hereunder and as authorized by Customer, Customer will provide Seller and Seller's Representative with authorization to install pulse equipment as defined in Attachment B.

SECTION 1 FEES AND PAYMENT

Compensation for the Services and remittances pursuant to the applicable Program, is as follows and further outlined in Attachment DR-1:

1.02 Proceeds. Proceeds from Customer's participation in Programs shall be distributed pursuant to Attachment DR-1.

1.03 Services Fee. As compensation for performance by Seller, or Seller's Representative, of the Services for each Participating Load under this Exhibit, Seller's Representative shall withhold, or cause to be withheld, the remaining percentage of proceeds after remitting the revenue sharing percentage listed for each Participating Load by site number in Attachment DR-1 (the "Services Fee").

1.04 Remittance to Customer. Seller's Representative will remit, or cause to be remitted, to Customer all remaining proceeds after deduction for the Services Fee and other authorized charges as described herein.

1.05 Invoices and Payments. Settlement Statements and invoices shall be sent to the Customer at:
Lamar CISD
3911 Avenue I
Rosenberg, Texas 77471

1.06 Records. Customer (or any of its agents, auditors, or consultants) shall have the right upon five (5) business days' notice to examine the applicable books and records relating to Customer kept by Seller or Seller's Representative. Seller or Seller's Representative shall make available to Customer at Seller's Representative's principal place of business all applicable records, documents, and other materials pertaining to Customer.

SECTION 2 REPRESENTATIONS

2.01 Representations. Customer, Seller and Seller's Representative each hereby represents as of the Effective Date that (a) it is duly formed and validly existing in the jurisdiction of its formation, (b) it has all authority to execute and perform the obligations set forth in this Exhibit, (c) this Exhibit has been duly executed and delivered by such Party, and (d) this Exhibit represents the legal, valid, and binding obligations of such Party, enforceable against it in accordance with the terms, except as enforceability may be limited by sovereign immunity of Seller (which expressly is not waived by Seller hereunder, either as to suit or liability) or governmental immunity of Customer (which expressly is not waived by Customer hereunder either as to suit or liability), bankruptcy, insolvency, or other similar laws affecting creditors' rights generally and general principles of equity.

2.02 Obligations Following Termination. Expiration or termination of this Exhibit shall not relieve any Party of liability that has accrued or arisen prior to the date of such expiration or termination.

2.03 Independent Contractor. Except as provided in this Exhibit and, subject to Seller's written authorization, Seller's Representative shall have the full power and authority to select the means, methods, and manner of performing the Services under this Exhibit, and shall be responsible to the Seller and Customer only for the contracted Services. Performance of the Services under this Exhibit shall comply with Prudent Industry Practices and with the Seller and Customer's specific written recommendations or instructions, if any, and shall be performed subject to the overall

direction of Customer. No employees of Seller or Seller's Representative are, or shall be deemed to be, employees of Customer. Seller's Representative shall be responsible for payment of all Taxes arising from activities under this Exhibit, including, by way of illustration but not limitation, federal and state income, sales and use taxes, social security taxes, unemployment insurance taxes, and any other taxes or business license fees as required.

2.04 Appointment. Subject to the terms and conditions of this Exhibit, Customer hereby appoints and authorizes Seller, and Seller's Representative, to act as its independent contractor and agent for the purposes described herein.

2.05 Certain Limitations. Notwithstanding anything to the contrary contained herein, Seller's Representative shall have no authority to and shall not (and shall not permit any of its employees, contractors, or representatives to) on behalf of the Seller or Customer: (a) settle or waive any material claims of Customer or enforce any material rights of Customer except as provided for pursuant to a Program; (b) enter into, amend, or terminate any contract of Customer; (c) pledge, mortgage, encumber, create any lien on, or make any license or exchange of, any property or assets of Customer; or (d) take any actions contemplated by the terms of this Exhibit without prior approval of such actions by Seller or Customer as applicable.

2.06 ERCOT Affirmations. Customer affirms the following:

- (a) Customer controls the ERS Resource, as defined in the ERCOT Protocols and herein, and is hereby providing written authorization for Seller and Seller's Representative (i) to obtain historical meter data or other information as required by ERCOT, (ii) to submit ERS offers on its behalf and (iii) to represent Customer in all matters before ERCOT concerning Customer's provision of ERS;
- (b) Seller and Seller's Representative shall comply with and be bound by applicable ERCOT Protocols and PUC Rules in connection with remotely controlling Customer's generator(s);
- (c) Except when being used for standby power during an emergency, the capacity being offered under ERS is not capacity that is separately obligated under a separate Program to respond during any of the same hours occurring in the contracted ERS Time Period.
- (d) Customer has arranged for Seller's Representative, as the controlling entity of the ERS Capacity in conjunction with remotely controlling such ERS Capacity, to remain familiar with any applicable federal, state or local environmental regulations that apply to the use of any generator in the provision of ERS Capacity, and that the use of such generator(s) to provide ERS would not violate those regulations. This provision applies to both ERS Generators and to the use of backup generation by ERS Loads, as both terms are defined in the ERCOT Protocols.

SECTION 3 MISCELLANEOUS

3.01 Amendments. Except as otherwise expressly provided in the Agreement, any provision of this Exhibit may be modified or supplemented only by an instrument in writing signed by Seller, Customer, Cavallo, and Seller's Representative, and any provision of this Exhibit may be waived by the affected Party so long as such waiver is in writing, provided, however, that no waiver of any breach or default of any provision of this Exhibit shall be deemed a waiver of any subsequent breach or default. Any such amendment or waiver shall be binding upon all Parties hereto.

3.02 Survival. The obligations of the parties concerning payment under Section 1 shall survive the expiration or early termination of this Exhibit for a period necessary to accomplish payment to any Party as contemplated in Section 1 or to resolve a disputed payment as contemplated in Section 1. Also, any obligation of the Parties concerning any Services provided for on Attachment DR-1 and any associated documents, the term of which obligation extends beyond termination or expiration, shall remain in effect until satisfaction or earlier termination of such Service. In addition, each representation and warranty made herein or pursuant hereto shall survive the making of such representation and warranty, and no Party shall be deemed to have waived, by reason of taking or failing to take any action hereunder, any default that may arise by reason of such representation or warranty proving to have been false or misleading, notwithstanding that such Party may have had notice or knowledge or reason to believe that such representation or warranty was false or misleading at the time such Party took or failed to take such action.

IN WITNESS WHEREOF, the Parties hereto have caused this Exhibit to be executed by their authorized representatives the date shown below.

Texas General Land Office (Seller)

By: _____
Name: _____
Title: _____
Date: _____

SA _____ Deputy _____

DIV _____ GC _____

THE PERSON SIGNING THIS EXHIBIT ON BEHALF OF THE CUSTOMER CERTIFIES THAT THEY ARE AUTHORIZED TO LEGALLY OBLIGATE THE CUSTOMER.

CUSTOMER: LAMAR CONSOLIDATED ISD

By: _____
Name: _____
Title: _____
Date: _____

THE PERSON SIGNING THIS EXHIBIT ON BEHALF OF CAVALLO CERTIFIES THAT THEY ARE AUTHORIZED TO LEGALLY OBLIGATE CAVALLO. CAVALLO ENERGY TEXAS LLC IS A SIGNATORY TO THIS EXHIBIT FOR PURPOSES OF AGREEING TO ITS OBLIGATIONS TO PERFORM CERTAIN OBLIGATIONS FOR SELLER AND CUSTOMER AS PROVIDED HEREIN.

CAVALLO ENERGY TEXAS LLC

By: _____
Name: _____
Title: _____
Date: _____

THE PERSON SIGNING THIS EXHIBIT ON BEHALF OF SELLER'S REPRESENTATIVE CERTIFIES THAT HEIS AUTHORIZED TO LEGALLY OBLIGATE SELLER'S REPRESENTATIVE. SELLER'S REPRESENTATIVE IS A SIGNATORY TO THIS EXHIBIT FOR PURPOSES OF AGREEING TO ITS OBLIGATIONS TO PERFORM CERTAIN OBLIGATIONS FOR SELLER AND CUSTOMER AS PROVIDED HEREIN.

LINKS EP, LLC

By: _____
Name: _____
Title: _____
Date: _____

Attachment DR-1

Emergency Response Services

Program Description:

- a) The Electric Reliability Council of Texas (ERCOT) enables program participants to earn revenue for availability to manage supply and demand to emergency conditions on the power grid.
- b) ERCOT will deploy ERS (whether by test or actual event deployment) a minimum of one time per year.
- c) An ERS Resource may not participate in any other demand response program in ERCOT during any hours that they are committed to ERS.

Monthly Settlement Terms: For the ERS Program, Seller’s Representative will remit payments to Customer within 30 days from the end of the applicable Program Period after Seller’s Representative receives payment from ERCOT.

- a. **Revenue Sharing** – For Customer’s demand response capacity sales to ERCOT, the parties acknowledge that Seller’s Representative will receive revenues, based off customer capacity obligation submitted and awarded multiplied by the availability percentage determined by ERCOT in the corresponding auction period. Customer will receive 80% (Eighty Percent) of the Demand Response settlement amount.
- b. **Monthly Settlement** – Monthly settlement terms with Customers for the applicable Services are set out in the Exhibits attached hereto. The Parties acknowledge that fees received from ERCOT will be administered in accordance with the financial settlement process in the ERCOT Protocols. The Parties agree that any adjustments subsequent to the initial ERCOT settlement statement shall be remitted to the Party owed. The Parties recognize that Emergency Response Services (“ERS”) disbursements from ERCOT may occur less frequently than monthly.

Program Rules:

Program Periods	Feb. 1 through May 31st, June 1 through Sept. 30 and Oct. 1 through Jan. 31 (each "program period", ERS events may be called upon during the "Time Periods" elected by the Customer.
Time Period Name	Time Period Hours
Business Hours 1	Hours Ending 0600 – 0800 (5:00:00a.m. to 8:00:00a.m.) Monday through Friday except ERCOT Holidays
Business Hours 2	Hours Ending 0900 - 1300 (8:00:00a.m. to 1:00:00p.m.) Monday through Friday except ERCOT Holidays.
Business Hours 3	Hours Ending 1400 - 1600 (1:00:00p.m. to 4:00:00p.m.) Monday through Friday except ERCOT Holidays.
Business Hours 4	Hours Ending 1700 - 1900 (4:00:00p.m. to 7:00:00p.m.) Monday through Friday except ERCOT Holidays.
Business Hours 5	Hours Ending 2000 - 2200 (7:00:00p.m. to 10:00:00p.m.) Monday through Friday except ERCOT Holidays.
Business Hours 6	All other hours
Notification	Customer will have a maximum of 30 minutes advance notice
Event Frequency	Minimum one time per Program Period (one test)

	ESI ID	Service Address
1		
2		
3		
4		
5		
6		
7		
8		
9		
10		

<u>Estimated Capacity (kW)</u>						
<i>Program Period</i>	<i>Program Hours 1</i>	<i>Program Hours 2</i>	<i>Program Hours 3</i>	<i>Program Hours 4</i>	<i>Program Hours 5</i>	<i>Program Hours 6</i>
Feb – May						
June – Sept						
Oct – Jan						

CUSTOMER:

By: _____

Printed Name: _____

Title: _____

Date: _____

SELLER'S REPRESENTATIVE

LINKS EP, LLC

By: _____

Printed Name: _____

Title: _____

Date: _____

Attachment A

Demand Response Program - Contact Information Form

Customer:
Street Address:
City, State Zip Code:

Phone calls will be placed upon initiation and termination of an event using an automated communication system. Please provide the name, primary and/or secondary number for individuals (in call order) to be contacted during the beginning and end of an event. These contacts should only include personnel that are responsible for implementing the demand response measures. Once confirmation is received from any contact on the list the system will make no additional calls. Confirmation is achieved once the recipient presses any numeric key, listens to the message, and then presses "1" to confirm. Phone calls are the primary source of notification for an event. Simultaneously, an e-mail notification will be sent to all the email addresses provided below. Emails are a secondary source of notification as an FYI of an event.

Please fill in the required information below for **EVENT** issues:

Name	Mobile Phone Number	Office Phone Number	Email Address

Please fill in the required information below for **NON-EVENT** issues.

Name	Phone Number	E-mail Address

NOTE: The person whose information is provided in the NON-Event informational box will not be contacted during an event.

Please contact the NOC at Links EP either by phone at (888) 313-9654 or by email at ersnotifications@linksep.com if you have any questions.

Attachment B

Letter of Authorization for Installation of Pulse Equipment (LOA)

Date:

Attn:

TDSP(s):

Re: Installation of Pulse Equipment

Lamar CISD _____ (“Customer”) grants Links EP, LLC permission to act on behalf of the Customer to order advanced metering service for the following ESI IDs.

ESI ID Number

Service Address

As required

Your assistance in this matter is as always greatly appreciated. If you have questions or if I may be of additional assistance please let me know.

Regards,

Signature: _____

Name: _____

Title: _____

Company: _____

Address: _____

City: _____

State: _____

Zip: _____

Phone: _____

**CONSIDER APPROVAL OF CENTERPOINT ENERGY TERMS AND CONDITIONS
FOR FOSTER HIGH SCHOOL NATATORIUM**

RECOMMENDATION:

That the Board of Trustees approve the CenterPoint Energy terms and conditions package for the installation of overhead and underground electric service at Foster High School Natatorium in the amount of \$30,906.19 and authorize the Board President to execute the agreement documents.

IMPACT/RATIONALE:

The terms and conditions are required to be executed for CenterPoint Energy to provide electric service for Foster High School Natatorium. CenterPoint documents are separated into overhead (\$13,806.19) and underground (\$17,100.00) work for a combined total of \$30,906.19 for the electric service.

These funds were allocated within the 2014 Bond Budget.

PROGRAM DESCRIPTION:

Upon approval, the Board President will execute the agreement documents and CenterPoint Energy will begin design and installation of the permanent electrical service for Foster High School Natatorium.

Submitted By: Kevin McKeever, Administrator for Operations
Steve Hoyt, Vanir/Rice & Gardner Consultants, Inc., A Joint Venture

Recommended for approval:



Dr. Thomas Randle
Superintendent

CenterPoint Energy Houston Electric, LLC
Applicable: Entire Service Area

CNP 8038

6.3 AGREEMENTS AND FORMS

6.3.1 FACILITIES EXTENSION AGREEMENT

This Facilities Extension Agreement is entered into by and between _____
Lamar Consolidated Independent School District _____, herein
called "Retail Customer" and CenterPoint Energy Houston Electric, LLC, herein called
"Company" (hereinafter referred to as Agreement) for the construction, extension, installation,
modification, repair, upgrade, conversion, relocation, de-energization or removal of Company's
Delivery System, including temporary facilities (hereinafter referred to as facilities extension or
extension), as described herein.

This Agreement covers the facilities extension to Retail Customer location at _____
4300 FM 723 Rd. PP, Richmond, TX 77406 _____

The Company agrees to accept payment of \$13806.19 Dollars
to be paid by the Retail Customer, as a Non-Refundable Construction Payment in connection
with the Retail Customer request to extend Company facilities to the above described location as
follows: Installation of poles, line and equipment that are not in standard service.

- Unless otherwise stated by Company in writing, the Non-Refundable Construction Payment amount above is valid for twelve months.

In consideration of said Non-Refundable Payment, to be paid to Company by Retail Customer prior to commencement of construction, Company agrees to install and operate lines and equipment necessary to distribute electric service to the identified location under the following General Conditions:

- Company shall at all times have title to and complete ownership and control over facilities installed by Company.
- Retail Customer must make satisfactory payment arrangements (if payment is required to extend Company facilities) and sign and return this Agreement before Company can proceed with the requested extension.



SERVICE OUTLET LOCATION AND DATA STATEMENT FOR ELECTRIC SERVICE

CUSTOMER Lamar Consolidated Independent School District	DAY PHONE 832 -223 -0000
SERVICE ADDRESS 4300 FM 723 Rd. PP, Richmond, TX 77406	EVENING PHONE
MAILING ADDRESS	PAGER
ELECTRICIAN	CELL PHONE

Dear Customer,

CenterPoint Energy Houston Electric, LLC is grateful to meet with you on, 12-19-2017 to discuss the requirements needed to provide you electric service. DATE

<ul style="list-style-type: none"> CenterPoint Energy Construction Required? <input checked="" type="checkbox"/> YES <input type="checkbox"/> NO The following steps must be complete prior to construction: <ul style="list-style-type: none"> <input checked="" type="checkbox"/> Pay any up-front contributions for non-standard service \$ 13,806.19 _____ <input type="checkbox"/> Clear trees along extension route <input type="checkbox"/> Easement charges \$ _____ <input type="checkbox"/> Easement execution 	<p>To begin the process we request that you provide the following information:</p> <ul style="list-style-type: none"> <input checked="" type="checkbox"/> Site Plan and Elevation Plan: Hard Copies <input checked="" type="checkbox"/> Site Plan: Electronic Copy with XY Coordinates <input checked="" type="checkbox"/> One Line Diagram <input checked="" type="checkbox"/> Load Analysis <input type="checkbox"/> Easements Required-Recorded Warranty Deed Required <input type="checkbox"/> Specifications on Modular Metering Enclosure.
---	--

The following steps must be completed prior to meter installation:

YES NO

- Installation of meter pole or weather head (as located on sketch)
- Obtain city or county permit - For contact information, call 713-207-2222 or 1-800-332-7143, or visit the website <http://www.centerpointenergy.com/houston/builders>
- Obtain an ESI ID# for your account - Either you the customer or your Competitive Retailer can get this number by calling 713-207-2222 or 1-800-332-7143
- Choose a Competitive Retailer - For listing, visit the website <http://www.powertochoose.org> or call 1-866-PWR-4-TEX(1-866-797-4839)

CenterPoint Energy Houston Electric, LLC's target completion date to provide your construction requirements, per the working sketch, is a mutually agreed upon negotiated date by CenterPoint Energy and customer. Please be aware our ability to meet the target completion date may be affected by weather, availability of construction crews and materials, ability to secure easements, and timely completion of your requirements (see above). In addition, as a condition to this service, you agree to comply with all of CenterPoint Energy standards, the National Electrical Code, the National Safety Code, all Occupational Safety and (OSHA) requirements, the International Building code and all local governing body codes.

We appreciate the opportunity to do business with you and look forward to the successful completion of this project. Your signature below insures that both parties understand the requirements toward completion that will allow you electrical service. Thanks for your cooperation in this matter.

Sincerely,

Service Consultant

SERVICE CONSULTANT Gabriel Gonzalez	PHONE NUMBER (281) 341-4908
ADDRESS PO BOX 231; Rosenberg TX 77471	
E-MAIL ADDRESS gabriel.gonzalez@centerpointenergy.com	

CUSTOMER'S SIGNATURE 	
CUSTOMER'S PRINTED NAME James Steenbergen - Board President	DATE

YES NO	<input type="checkbox"/> <input checked="" type="checkbox"/> Will Customer have Back-up Generation?
<input type="checkbox"/> <input checked="" type="checkbox"/> Will Customer have Motor Greater than 250 HP?	
APPLICABLE FORMS	
<input type="checkbox"/>	Power Quality
<input type="checkbox"/>	Primary Meter
<input type="checkbox"/>	Motor Start
<input type="checkbox"/>	Emergency Generation
<input type="checkbox"/>	Distributed Generation
<input type="checkbox"/>	Major UG Checklist

<p align="center">GENERAL SERVICE</p> <input type="checkbox"/> 1Ø 3W 120/208 <input type="checkbox"/> 1Ø 3W 120/240 <input type="checkbox"/> 3Ø 4W Δ 240V <input type="checkbox"/> 3Ø 4W Y 120/208V <input type="checkbox"/> 3Ø 4W Y 277/480V* *10 X 26 PT can mounted on 480V Service? <input type="checkbox"/> 3Ø 3W Δ 480V* *1-1/4" conduit connecting CT & PT can run? <input type="checkbox"/> Primary Metering Job <input type="checkbox"/> Major UG Job <input type="checkbox"/> Other: (Explain) _____ _____ _____	<p align="center">SERVICE TYPE</p> <p>_____ FT² <input type="checkbox"/> All Electric <input type="checkbox"/> Gas & Electric</p> <p>Size Wire Pulled _____</p> <p>Cust's Load 1 Ø _____ +3 Ø _____ = _____ Total KVA</p> <p>Fault Current: Initial _____ Ultimate _____</p> <p align="center">Amperes RMS Symmetrical at _____ Volts</p>
---	---

<p align="center">CT CAN TYPE</p> <input type="checkbox"/> 320 Amp (self contained) <input type="checkbox"/> 30 X 42 <input type="checkbox"/> Bus Head Outdoor <input type="checkbox"/> Bus Head with CT Can <input type="checkbox"/> Stainless Steel Rack <input type="checkbox"/> Primary Job	<p align="center">CONDUITS ON POLE</p> <p align="center">Size of Conduit</p> <p align="center">_____</p> <p align="center">No. of Conduits</p> <p align="center">_____</p>	<p align="center">For Information Regarding:</p> <p align="center">CenterPoint Energy service standards visit</p> <p align="center">www.centerpointenergy.com/electricservicestandards</p> <p align="center">or</p> <p align="center">For Gas service call (713) 659-2111</p>
---	---	--

COMMENTS OR NOTES

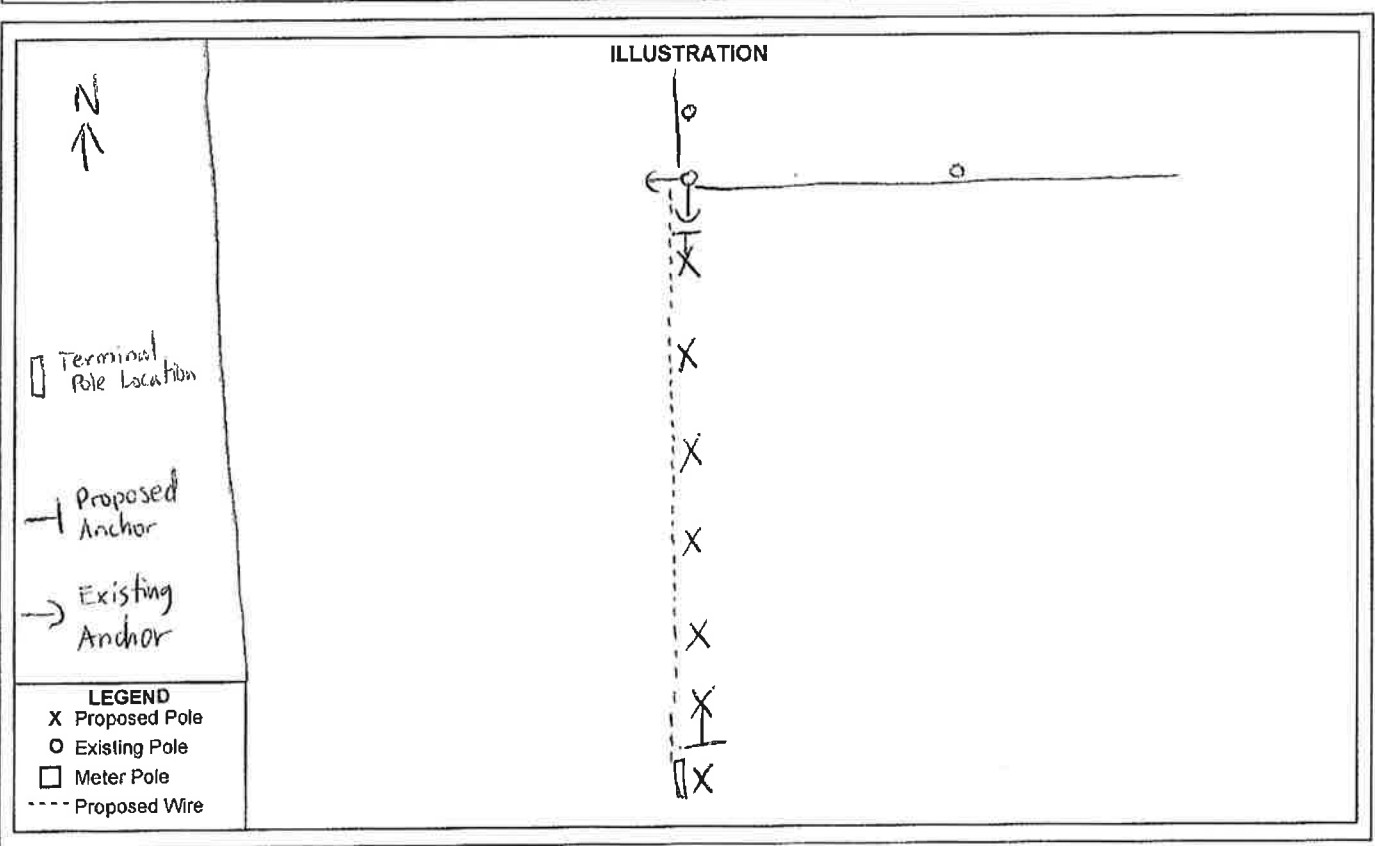

**TEXAS LAW AN ACT
TEXAS HEALTH AND SAFETY CODE TITLE 9**

CHAPTER 752 - Safety of persons engaged in activities in proximity of high voltage electric lines; restrictions

SECTION 001. DEFINITIONS

- (1) "High voltage" means more than 600 volts measured between conductors or between a conductor and the ground.
- (2) "Overhead line" means a bare or insulated electric conductor installed above ground but does not include a conductor that is de-energized and grounded or that is enclosed in a rigid metallic conduit.

SECTION 002. EXEMPTION FOR CERTAIN EMPLOYEES AND ACTIVITIES

(A) This chapter does not apply to the construction, reconstruction, operation, or maintenance by an authorized person of overhead electrical or communication circuits or conductors and their supporting structures and associated equipment that are part of a rail transportation system, an electrical generating, transmission, or distribution system or a communication system.

- (B) In this section, "authorized person" means:
- (1) an employee of a light and power company, an electric cooperative, or a municipality working on his employer's electrical system;
 - (2) an employee of a transportation system working on the system's electrical circuits;
 - (3) an employee of a communication utility;
 - (4) an employee of a state, county, or municipal agency that has authorized circuit construction on the poles or structures that belong to an electric power company, an electric cooperative, a municipal or transportation system, or a communication system;
 - (5) an employee of an industrial plant who works on the plant's electrical system; or
 - (6) an employee of an electrical or communications contractor who is working under the contractor's supervision.

SECTION 003. TEMPORARY CLEARANCE OF LINES

(A) A person, firm, corporation, or association responsible for temporary work or a temporary activity or function closer to a high voltage overhead line than the distances prescribed by this chapter must notify the operator of the line at least 48 hours before the work begins.

(B) A person, firm, corporation, or association may not begin the work, activity, or function under this section until the person, firm, corporation, or association responsible for the work, activity, or function and the owner or operator, or both, of the high voltage overhead line have negotiated a satisfactory mutual arrangement to provide temporary de-energization and grounding, temporary relocation or raising of the line, or temporary mechanical barriers to separate and prevent contact between the line and the material or equipment or the person performing the work, activity or function.

(C) The person, firm, corporation, or association responsible for the work, activity, or function shall pay the operator of the high voltage overhead line the actual expense incurred by the operator in providing the clearance prescribed in the agreement. The operator may require payment in advance and is not required to provide the clearance until the person, firm, corporation, or association responsible for the work, activity, or function makes the payment.

(D) If the actual expense of providing the clearance is less than the amount paid, the operator of the high voltage overhead line shall refund the surplus amount.

SECTION 004. RESTRICTION ON ALL ACTIVITIES NEAR LINES

(A) Unless a person, firm, corporation, or association effectively guards against danger by contact with the line as prescribed by Section 752.003, the person, firm, corporation, or association, either individually or through an agent or employee, may not perform a function or activity on land, a building, a highway, or other premises if at any time it is possible that the person performing the function or activity may:

- (1) move or be placed within six feet of a high voltage overhead line while performing the function or activity; or
 - (2) bring any part of a tool, equipment, machine, or material within six feet of a high voltage overhead line while performing the function or activity.
- (B) A person, firm, corporation, or association may not require an employee to perform a function or activity prohibited by Subsection (A).

SECTION 005. RESTRICTION ON OPERATION OF MACHINERY AND PLACEMENT OF STRUCTURES NEAR LINES

Unless a person, firm, corporation, or association effectively guards against danger by contact with the line as prescribed by Section 752.003, the person, firm, corporation, or association, either individually or through an agent or employee, may not:

- (1) erect, install, transport, or store all or any part of a house, building, or other structure within six feet of a high voltage overhead line;
- (2) install, operate, transport, handle, or store all or any part of a tool, machine, or equipment within six feet of a high voltage overhead line; or
- (3) transport, handle, or store all or any part of supplies or materials within six feet of a high voltage overhead line.

SECTION 006. RESTRICTION ON OPERATION OF CERTAIN MACHINERY OR EQUIPMENT

(A) A person, firm, corporation, or association, individually, through an agent or employee, or as an agent or employee, may not operate a crane, derrick, power shovel, drilling rig, hayloader, haystacker, mechanical cotton picker, pile driver, hoisting equipment, or similar apparatus any part of which is capable of vertical, lateral, or swinging motion unless:

- (1) a warning sign is posted and maintained as prescribed by Subsections (B) and (C);
 - (2) an insulated cage-type guard or protective device is installed about the boom or arm of the equipment, except a backhoe or dipper; and
 - (3) each lifting line, if the equipment includes a lifting hook device, is equipped with an insulator link on the lift hook connection.
- (B) The warning sign required by Subsection (A) (1) must be a weather-resistant sign of not less than five inches by seven inches with a yellow background and black lettering that reads:
"WARNING -- UNLAWFUL TO OPERATE THIS EQUIPMENT WITHIN TEN FEET OF HIGH VOLTAGE LINES."

(C) The warning sign must be legible at 12 feet and placed:

- (1) within the equipment so that it is readily visible to the equipment operator while at the equipment controls; and
- (2) on the outside of the equipment in the number and location necessary to make it readily visible to a mechanic or other person engaged in the work.

(D) Notwithstanding the distance limitations prescribed by Sections 752.004 and 752.005, unless a person, firm, corporation, or association effectively guards against danger by contact with the line as prescribed by Section 752.003, the person, firm, corporation, or association may not operate all or any part of a machine or equipment described by this section within 10 feet of a high voltage overhead line.

SECTION 007. CRIMINAL PENALTY

- (A) A person, firm, corporation, or association or an agent or employee of a person, firm, corporation, or association commits an offense if the person, firm, corporation, association, agent, or employee violates this chapter.
- (B) An offense under this section is punishable by a fine of not less than \$100 or more than \$1,000, confinement in jail for not more than one year, or both.

SECTION 008. LIABILITY FOR DAMAGES

If a violation of this chapter results in physical or electrical contact with a high voltage overhead line, the person, firm, corporation, or association that committed the violation is liable to the owner or operator of the line for all damages to the facilities and for all liability that the owner or operator incurs as a result of the contact.

Acts 1989, 71st Leg., ch. 678, § 1, eff. Sept. 1, 1989
Prior Laws:
Acts 1971, 62nd Leg., p. 76, ch. 41.
Vernon's Ann. Civ. St. art. 1436c, § 7(B).

This is only a part of the entire act. The complete act is available for review.



Rut Letter Agreement

Date: 12/20/2017

Fort Bend Service Center
4011 Avenue H
Rosenberg, TX: 77471

Dear CenterPoint Energy Customer:

Providing electrical service to your address in a timely manner is important to me and to our company. CenterPoint Energy Houston Electric, LLC (CenterPoint Energy) construction crews and/or our contractors will be doing construction on your Property at your request, as per the Service Outlet Location. While doing this construction, it may be necessary for large machinery, equipment and/or vehicles to enter the Property at the location designated below. Although this equipment is often heavy, CenterPoint Energy will make every effort to minimize ruts or damage to the Property. Unfortunately, the current condition of the Property makes it likely that ruts or damage will occur. CenterPoint Energy would normally defer construction until the Property is in a condition to properly support its vehicles and equipment, and would not proceed with construction under the current conditions without being fully released and indemnified should damage to the Property occur.

By electing below to proceed with construction under conditions that may cause ruts or damage to the Property, the Customer signing below agrees to **release, protect, indemnify, and hold CenterPoint Energy, its affiliates, officers, employees and contractors free and harmless from and against any and all claims, demands, causes of actions, suits, damages to property or other litigation (including all costs thereof and attorney's fees) (the Damages) of any kind and character arising in favor of any person(s), where such Damages are caused by or arise out of the construction activities of CenterPoint Energy employees or contractors upon the Property, and even where the damages are alleged to be caused by the negligence of CenterPoint Energy or its contractors.**

➤ Please indicate your preference by initialing one of the following choices:

X CenterPoint Energy can proceed with the construction under current conditions that may cause ruts or damage to the Property.

CenterPoint Energy may delay construction until the Property is in a condition to properly support its vehicles and/or the equipment necessary for construction.

Please return this form to me at your earliest convenience at the above address or fax to (281) 341-4991, or feel free to call me at (281) 341-4908 with any questions you might have.

Sincerely, 
Gabriel Gonzalez
Service Consultant
Fort Bend Service Center

Customer*: _____ Date: _____

Print Name: James Steenberg Title: Board President

Construction Address (the Property): 4300 FM 723 Rd. PP, Richmond, TX 77406

***If the person signing this Agreement is not the Owner of the Property, that Person must be authorized by the Owner to sign the Agreement.**

CenterPoint Energy Houston Electric, LLC
Applicable: Entire Service Area

(6-2012)
CNP 8038

6.3 AGREEMENTS AND FORMS

6.3.1 FACILITIES EXTENSION AGREEMENT

This Facilities Extension Agreement is entered into by and between Lamar Consolidated I.S.D., herein called "Retail Customer" and CenterPoint Energy Houston Electric, LLC, herein called "Company" (hereinafter referred to as Agreement) for the construction, extension, installation, modification, repair, upgrade, conversion, relocation, de-energization or removal of Company's Delivery System, including temporary facilities (hereinafter referred to as facilities extension or extension), as described herein.

This Agreement covers the facilities extension to Retail Customer location at 4300 FM 723 Rd. PP, Richmond, Texas 77406.

The Company agrees to accept payment of \$17,100.00 Dollars to be paid by the Retail Customer, as a Non-Refundable Construction Payment in connection with the Retail Customer request to extend Company facilities to the above described location as follows: For requested underground service facilities in accordance with Terms and Conditions package Job# 82174818. This cost is based on utilizing the Company's standard installation equipment. The cost does not include overtime premiums. This agreement includes no cost for the extension, modification or removal of the existing overhead facilities. Please contact the Company's respective Service Center representative for any additional costs that may be associated with this project.

- Unless otherwise stated by Company in writing, the Non-Refundable Construction Payment amount above is valid for twelve months.

In consideration of said Non-Refundable Payment, to be paid to Company by Retail Customer prior to commencement of construction, Company agrees to install and operate lines and equipment necessary to distribute electric service to the identified location under the following General Conditions:

- Company shall at all times have title to and complete ownership and control over facilities installed by Company.
- Retail Customer must make satisfactory payment arrangements (if payment is required to extend Company facilities) and sign and return this Agreement before Company can proceed with the requested extension.

CenterPoint Energy Houston Electric, LLC
Applicable: Entire Service Area

- Extension of service facilities is contingent on acquisition of all necessary easements and rights of way.

Nothing herein contained within this Agreement shall be construed as a waiver or relinquishment by Company of any right that it has or may hereafter have to discontinue service for or on account of default in the payment of any bill owing or to become owing thereafter for any other reason or cause stated in Company's Tariff.

This Agreement shall not be binding upon Company unless and until it is signed by an authorized representative of the Company.

CenterPoint Energy Houston Electric, LLC

Lamar Consolidated I.S.D.

Retail Customer

By Frank De Leon

By _____
Signature

Frank De Leon

Name printed or typed

James Steenbergen

Name printed or typed

Title Senior Engineering Specialist

Title Board President

Date December 13, 2017

Date _____

**TERMS & CONDITIONS
UNDERGROUND ELECTRIC SERVICE**

FOR

**LAMAR CONSOLIDATED I.S.D.
Foster High School Practice Pool
4300 FM 723 Rd. PP, Richmond, Texas 77406**

Job #82174818

**CenterPoint Energy
Major Underground Engineering
P. O. Box 1700; Houston, Texas 77251-1700**

REFERENCE LAMAR CONSOLIDATED I.S.D. DRAWINGS:

Site Plan	Drawing #:	<u>E1.00C</u>	Received:	<u>May 11, 2017</u>
Electrical One-Line	Drawing #:	<u>E5.01</u>	Received:	<u>April 25, 2017</u>
Load Analysis	Drawing #:	<u>E5.01</u>	Received:	<u>April 25, 2017</u>

REFERENCE CENTERPOINT ENERGY SPECIFICATIONS:

Service Standards	:	May 1, 2016
Emergency Generators	:	007-231-82
Ready-Mix Concrete	:	007-221-01
Harmonic Distortion	:	007-231-83

Reviewed And Agreed To By: _____ Board President _____
Signature Title Date

James Steenberg
Print Name

If this Terms & Conditions package is signed by anyone other than an official from **Lamar Consolidated I.S.D.**, it will not be considered valid. A valid signature will be considered an acceptance of all information contained within this Terms & Conditions package.

						CenterPoint Energy Houston, Texas		
						WRITTEN	FD	12/13/2017
						CHECKED	AAO <i>AS</i>	12/13/2017
						APPROVED	AAO	12/13/2017
							SHEET 1 OF 15 SHEETS	
NO.	DATE	ITEMS REVISED	BY	CH	APP	PM 3345		

GENERAL

- A. These Terms and Conditions are for a service arrangement for Lamar Consolidated I.S.D. Lamar Consolidated I.S.D. and/or its contractors/representatives are herein referred to as the Customer.
- B. Service to be provided by CenterPoint Energy (CNP) from a 300 kVA, 34.5 kV - 480Y/277 V, three phase, four wire, pad mounted transformer.
- C. The CNP Major Underground Engineering (MUG) representative is Frank De Leon at 713-207-4941 or frank.deleon@centerpointenergy.com.

The CNP Service Area Consultant is Gabriel I Gonzalez at 281-341-4908.
- D. The Customer must comply with all CNP Service Standards, the National Electrical Code, the National Electrical Safety Code, all Occupational Safety and Health Administration (OSHA) requirements, the International Building Code and all local governing body codes.
- E. During installation of CNP equipment, CNP will make every effort to preserve the Customer's landscaping, parking areas, or other facilities. However, any cost that has been quoted to the Customer does not include any special replacements or repairs to these items. The Customer shall be solely responsible for any expenses associated with replacements or repairs to its facilities.
- F. The service arrangement outlined in these Terms and Conditions is based on the Customer drawings referenced on page 1. Any changes in the design as illustrated in the referenced drawings may impact CNP's ability to meet the Customer's requested service date.
- G. Any changes, additions, deletions, rearrangements, relocations, rerouting, reduction of clearances, etc., of the Customer's and/or CNP's service facilities illustrated in these Terms and Conditions shall have MUG's approval and may require a revised Terms and Conditions. It is the Customer's responsibility to coordinate the location of all Customer installed facilities outlined in these Terms and Conditions with all other structures and/or appurtenances not shown in the referenced drawings.
- H. Contact the MUG representative concerning Customer drawing revisions, information submission, questions, Terms and Conditions revision requests, etc.
- I. Hard copy submittals may be mailed to the MUG representative (address - 3000A Harrisburg Blvd. - Houston, Texas 77003). Electronic submittals may be e-mailed to the MUG representative. The MUG representative will; "approve the submittals", "approve the submittals as noted" or "not approve the submittals". The Customer shall not install any item that requires CNP approval before receiving an official approval from MUG. CNP shall not be responsible for any installed item that has not received MUG approval.

SERVICE CONNECTION

- A. The Customer's maximum number of secondary cables that can be terminated in CNP's pad mount transformer is 8-750 MCM cables per phase. The Customer shall advise the MUG representative, about the type, size and number of secondary conductors. Ampacity equivalent sets of cable must be individually approved by the MUG representative prior to installation by the Customer. If the Customer's cable requirements exceed this specified maximum limit, it cannot be served directly from the pad mounted transformer. The Customer shall then install, own, and maintain a cable tap box (CTB) (See Section D).
- B. On installations not utilizing a CTB, the Customer shall furnish, own, and maintain all secondary service conduit and cable underground into the secondary opening of the transformer pad. Secondary conductors shall be extended a minimum of seven feet (7') above the transformer pad. **The Customer shall not install the secondary cables until after the transformer has been set. CNP will terminate the secondary cables in the transformer.**
- C. To accommodate future expansion, the Customer may install up to 8-4" secondary conduits into the transformer pad.
- D. On installations utilizing a CTB, CNP shall furnish, own, install and terminate the secondary cable from the transformer to the CTB at the Customer's expense. The Customer shall furnish, install, own and maintain the CTB, the CTB pad, and 4-4" conduits from the secondary opening of the transformer pad to the CNP side of the CTB pad. The Customer shall install and terminate the secondary cable from its side of the CTB to its switchgear. Typical three-phase CTB drawings are available upon request. The Customer shall submit three (3) drawings of the proposed CTB to the MUG representative for approval prior to fabrication.
- E. The initial available short circuit current is 20,620 amperes symmetrical, with an X/R ratio of 3.0.
- F. The ultimate available short circuit current is 34,366 amperes symmetrical, with an X/R ratio of 3.1.
- G. Customers receiving electrical service from multiple sources will be required to install a permanent plaque or directory at each source in accordance with Article 230.2 of the National Electrical Code (NEC). These plaques are to signify that there is more than one electrical service to the building. The Customer shall keep the power from each source separate throughout its entire electrical system. This requirement is for the life of the service.
- H. A protective device coordination study for the Customer's service relative to CNP's protective devices may be requested by contacting the MUG representative.

ACCESS

The Customer must provide a twelve foot (12') minimum width, fourteen foot (14') minimum vertical clearance, all weather, vehicle access road designed for HS-20-44 loading as recognized by the American Association of State Highway Officials (AASHO), for CNP personnel and equipment ten feet (10') past the side of the proposed pad mounted equipment location. In addition, the area adjacent to the pad must be designed for HS-20-44 loading to allow for outrigger placement. If the access road and the pad mounted equipment location have not been completed and passed final inspection (see Final Inspection, page 7) at the time the Customer requests the equipment be set, the equipment can only be set under the following conditions.

- A. MUG has determined that the access route is dry and readily accessible to CNP's normal installation equipment.
- B. The Customer shall be responsible for all expenses associated with the repair and/or replacement of CNP pad mounted equipment damaged by additional construction activity. Damage to CNP equipment may result in delays to the Customer's requested service date.
- C. CNP will not complete the underground construction (i.e. pulling & terminating cable, energizing the service, etc.) until the access road and pad mounted equipment location have passed final inspection (see Final Inspection, page 7).

The Customer must provide a thirty two foot (32') minimum vertical clearance over all equipment pads for CNP trucks and equipment.

The Customer must maintain these requirements for the life of the service.

CNP will utilize the Customer's parking and driveway facilities for the required access.

EMERGENCY GENERATION AND SECONDARY LOAD TRANSFER

Customer installed Emergency Generators and/or Secondary Load Transfer schemes shall meet the requirements of the CNP Specification on Customer Emergency Generation and Secondary Load Transfer, Specification 007-231-82, latest revision (attached). This requirement is for the life of the service.

Generator exhaust must be located and/or directed away from CNP's equipment.

HARMONIC DISTORTION

The Customer shall meet the requirements of the CNP Specification on Limitation of Harmonic Distortion on the Distribution System, Specification 007-231-83, latest revision (available upon request). This requirement is for the life of the service.

REVISION NO.	SPECIFICATION NO.					SHEET 4 OF 15 SHEETS
--------------	-------------------	--	--	--	--	----------------------

METERING

- A. The Customer's metering arrangement must comply with CNP Service Standards, Section 400 or 500 as applicable.
- B. The metering current and potential transformers (CT's and PT's) will be installed in the secondary compartment of the transformer provided all service from the transformer is through one meter. If all the services are not through one meter, the Customer shall inform the MUG representative, so that alternate metering provisions can be arranged (separate CT and PT cans as required for each service).
- C. All Retail Customers must be metered separately.
- D. Meter Room and/or Modular Meter installations must have CNP written approval prior to the purchase/installation of materials/equipment. The Customer must submit applicable drawings to the MUG representative for approval.

FACILITIES INSTALLED BY THE CUSTOMER

All facilities are to be installed per the attached construction specifications. The Customer or its contractor is to request a preconstruction meeting prior to starting the required underground construction by calling the number listed below.

All facilities shall be inspected by CNP after the conduit is installed, pads are formed, reinforcing rods installed, etc. but prior to the pouring of concrete. CNP recommends that the Customer complete the pouring of concrete on the day the facilities are inspected and approved. The Customer will insure that all inspected and approved facilities remain in the approved condition until the concrete pour has been completed. If there is damage to the inspected and approved facilities prior to the pouring of concrete, the facilities must be re-inspected by CNP before the Customer begins the pouring of concrete. CNP reserves the right to require the Customer to break out any unapproved concrete pours at its expense.

CNP will make a reasonable attempt to complete all inspection requests. To insure that inspection requests can be fulfilled, they should be made twenty-four (24) hours in advance (Mon. - Fri.; between 9:00 a.m. and 3:00 p.m., holidays excluded) to Major Underground Engineering at (713) 207-6229. Job # 82174818 must be provided as the inspection identification number.

DUCTBANK INSTALLATION

All proposed conduit for CNP's use is to be installed in straight runs, unless otherwise indicated on CNP drawings. Any conduit bends must be installed with a twenty foot (20') minimum radius, unless indicated otherwise on CNP drawings. Conduit turn-ups into any equipment pad and/or pole pedestal must have a minimum five foot (5') radius. Any deviations from these requirements shall have written approval from the MUG representative prior to installation.

During installation, the minimum depth for a conduit run must be referenced to the final grade.

The Customer is to delay installation of approximately the last twenty feet (20') of the conduit run and the pole pedestal to any terminal pole until the pole has been set by CNP. Before trenching to the base of any terminal pole, the Customer must securely brace the pole. The Customer must request staking and setting of any terminal pole by contacting the Service Area Consultant.

The Customer must provide a jet line in each conduit installed. This jet line shall extend a minimum of seven feet (7') beyond the end of each conduit.

DUCTBANK INSTALLATION (continued)

For installations not utilizing a blanket easement document (see Easement Instrument section, page 7), the Customer shall also install a #14 American Wire Gage (AWG) or larger aluminum or copper 600 volt insulated conductor in one of the conduits. The conductor must be electrically continuous. For manhole installations, the electrically continuous conductor must also be looped through each manhole lid and tied to a concrete insert in the neck of each manhole. This conductor is to facilitate surveying of the duct bank by CNP. The duct bank cannot be surveyed until this conductor is installed as prescribed. The Customer must take adequate measures to assure the conductor will be in place until all necessary surveying is completed. After surveying of the duct bank is completed, but prior to CNP installing any primary cable, the Customer may retrieve its conductor at its option.

Conduit ends shall be plugged with a duct cap or other type capping device. The use of rags to plug conduits is not acceptable. If the conduit is installed in stages, the Customer must keep each section of conduit capped until the new section is installed. If, prior to CNP using any conduit, the conduit is found to be blocked, the Customer will be responsible, at its expense, for removing the obstruction.

CLEARANCES

Final approval for the location of the pad mount equipment and/or other proposed electrical installation is contingent upon proper clearance, as determined by CNP, from cooling towers, vents, buildings, structures, etc., and other underground utilities. It is in the Customer's and CNP's best interest to have all service equipment in a contamination-free environment to avoid unscheduled outages and/or premature equipment failures. Therefore, prior to any construction, the Customer shall inform the MUG representative of any existing or future contamination or pollutants which may affect the equipment so that necessary clearances can be secured.

The MUG representative shall be notified promptly if the Customer intends to install any obstructions such as walls, hedges, bushes, trees, etc., around the transformer and/or any associated equipment so that additional clearances and access can be secured. Any proposed enclosure surrounding CNP's equipment must be louvered, and both a profile and a cross-sectional view of the proposed louvered enclosure shall be submitted for approval prior to installation.

If, in the future, there is a problem with contamination of CNP's equipment, or proper clearances are not maintained, CNP reserves the right to relocate the equipment at the Customer's expense.

CNP will not allow other facilities to pass beneath its equipment pads. A one foot (1') minimum horizontal clearance shall be maintained between CNP pads and all other facilities.

A one foot (1') minimum vertical clearance must be maintained between CNP duct banks and all non-CNP facilities crossing the duct bank.

A five foot (5') minimum horizontal clearance must be maintained between CNP duct banks and other facilities running parallel to the duct bank. CNP will not allow joint trenching between CNP duct banks and other facilities.

ELEVATION REQUIREMENTS

The minimum elevation requirement for the top of the equipment pads shall be fifteen (15) feet above mean sea level or eighteen (18) inches above the documented 100 year floodplain, whichever is greater. The Customer must provide equipment pads that meet these elevation requirements. The easement (minimum working clearance) around the equipment pads shall also be brought up to the above mentioned minimum elevation, as outlined on the equipment pad detail specification. The easement area surrounding the equipment pads shall not have a slope greater than 2%. The pad and minimum easement elevations (minimum working clearance) must be verified at the time installation.

VENTILATION REQUIREMENTS

Any proposed barriers or enclosures in the vicinity of the equipment pads shall maintain a minimum of 50% free air flow. Prior to construction, the Customer shall submit drawings of the proposed barriers or enclosures to MUG Engineering Representative for approval.

FINAL INSPECTION

After the Customer has advised CNP that all "Customer installed" facilities pertaining to this service arrangement have been completed and inspected, a final on-site inspection will be made by a MUG representative. This final inspection will verify that all Customer installed facilities are in accordance with these Terms and Conditions. The Customer (or its contractor) and the Service Area Consultant will be advised of any needed corrections and/or changes. When all necessary corrections and/or changes have been completed, CNP's portion of the construction may begin.

EASEMENT INSTRUMENT

CNP will prepare an instrument for easements to be granted by the property owner after all installations for CNP's use have been completed according to these Terms and Conditions. The service cannot be energized until CNP has accepted the signed instrument for all easements.

The Customer also has the option of signing a blanket easement document. Use of the blanket easement allows the service to be energized before the final signed instrument for all easements has been completed. The Customer may request use of the blanket easement document by contacting the MUG representative.

CNP will need access to and from the proposed easements. CNP will use these easements, as shown on the attached sketches, for the purposes of erecting, installing, operating, maintaining, replacing, inspecting and removing electrical distribution facilities. The Customer shall keep these easements free and clear of any obstructions (trees, shrubs, other structures, etc.) that may endanger or interfere with the efficiency, safety, and proper operation of the proposed facilities for the life of the service.

REVISION NO.	SPECIFICATION NO.					SHEET 7 OF 15 SHEETS
--------------	-------------------	--	--	--	--	----------------------

INDEMNIFICATION AND LIABILITY LIMITS

Indemnity: This indemnity is pursuant to Company's Tariff located on our website at www.centerpointenergy.com.

RETAIL CUSTOMER ASSUMES THE RISK OF AND SHALL INDEMNIFY COMPANY AGAINST DAMAGES FOR INJURIES OR DEATH TO PERSONS OR LOSS TO RETAIL CUSTOMER'S PROPERTY, OR TO THE PROPERTY OF COMPANY, WHEN OCCASIONED BY ACTIVITIES OF RETAIL CUSTOMER OR THIRD PARTIES ON CUSTOMER'S PREMISES, RESULTING FROM THE INSTALLATION, EXISTENCE, REPLACEMENT, OR REPAIR OF COMPANY'S UNDERGROUND FACILITIES, AND AS FURTHER PROVIDED IN THE TERMS OF "LIMITS ON LIABILITY," SECTIONS 4.2 AND 5.2 OF THIS TARIFF. NOTWITHSTANDING ANY OF THE ABOVE, THE PROVISIONS REQUIRING A RETAIL CUSTOMER TO INDEMNIFY, FULLY PROTECT, OR SAVE COMPANY HARMLESS APPLY TO A GOVERNMENTAL ENTITY AS THIS TERM IS DEFINED IN CHAPTER 2251 OF THE TEXAS GOVERNMENT CODE, TO THE EXTENT OTHERWISE CONSISTENT WITH LAW; PROVIDED, HOWEVER, THAT ANY GOVERNMENTAL ENTITY THAT IS A RETAIL CUSTOMER TO WHICH THIS SUBSECTION 2.5 APPLIES MUST TAKE NECESSARY STEPS TO ENSURE THAT THE INDEMNIFICATION REQUIREMENTS OF THIS SUBSECTION 2.5 DO NOT CREATE A "DEBT" IN VIOLATION OF ARTICLE XI, SECTION 7 OF THE TEXAS CONSTITUTION. SUCH STEPS MAY INCLUDE, BUT ARE NOT NECESSARILY LIMITED TO, A THIRD-PARTY INDEMNIFICATION IN WHICH THE CONTRACTOR PERFORMING THE WORK FOR THE GOVERNMENTAL ENTITY INDEMNIFIES THE COMPANY OR THE ESTABLISHMENT OF A SINKING FUND. (See *Governmental Entity Addendum if applicable.*)

GENERAL LOCATION SKETCH

LAMBERT	SECTION	KEY MAP	FUNCTIONAL LOCATION	SCALE	CIRCUIT	ORDER NO.
4347	C2	564L	-	N. T. S.	BV41	-

LAMAR CONSOLIDATED I. S. D. (CUSTOMER) AND/OR ITS CONTRACTOR IS TO REQUEST A PRECONSTRUCTION MEETING PRIOR TO STARTING CONSTRUCTION BY CALLING (713) 207-6229

CENTERPOINT ENERGY (CNP) TO UTILIZE THE CUSTOMER'S PARKING AND DRIVEWAY FACILITIES FOR EQUIPMENT ACCESS

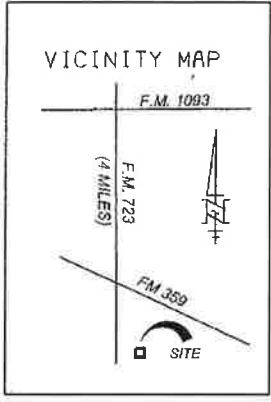
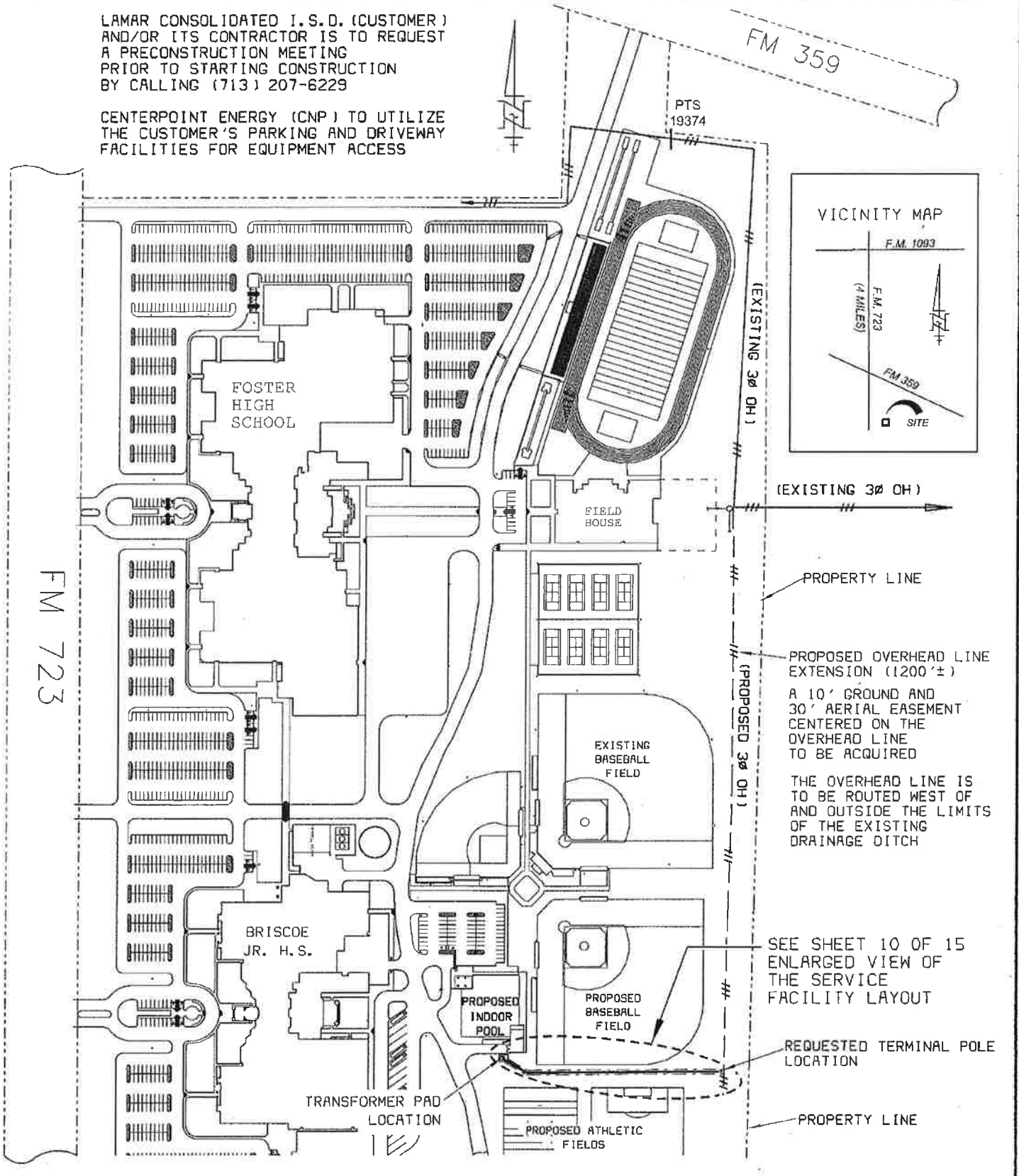

(EXISTING 3Ø OH)
(EXISTING 3Ø OH)
PROPERTY LINE
PROPOSED OVERHEAD LINE EXTENSION (1200'±)
A 10' GROUND AND 30' AERIAL EASEMENT CENTERED ON THE OVERHEAD LINE TO BE ACQUIRED
THE OVERHEAD LINE IS TO BE ROUTED WEST OF AND OUTSIDE THE LIMITS OF THE EXISTING DRAINAGE DITCH

SEE SHEET 10 OF 15 ENLARGED VIEW OF THE SERVICE FACILITY LAYOUT
REQUESTED TERMINAL POLE LOCATION
PROPERTY LINE

GENERAL LOCATION SKETCH

LAMBERT	SECTION	KEY MAP	FUNCTIONAL LOCATION	SCALE	CIRCUIT	ORDER NO.
4357	C2	564L	-	N. T. S.	BV41	-

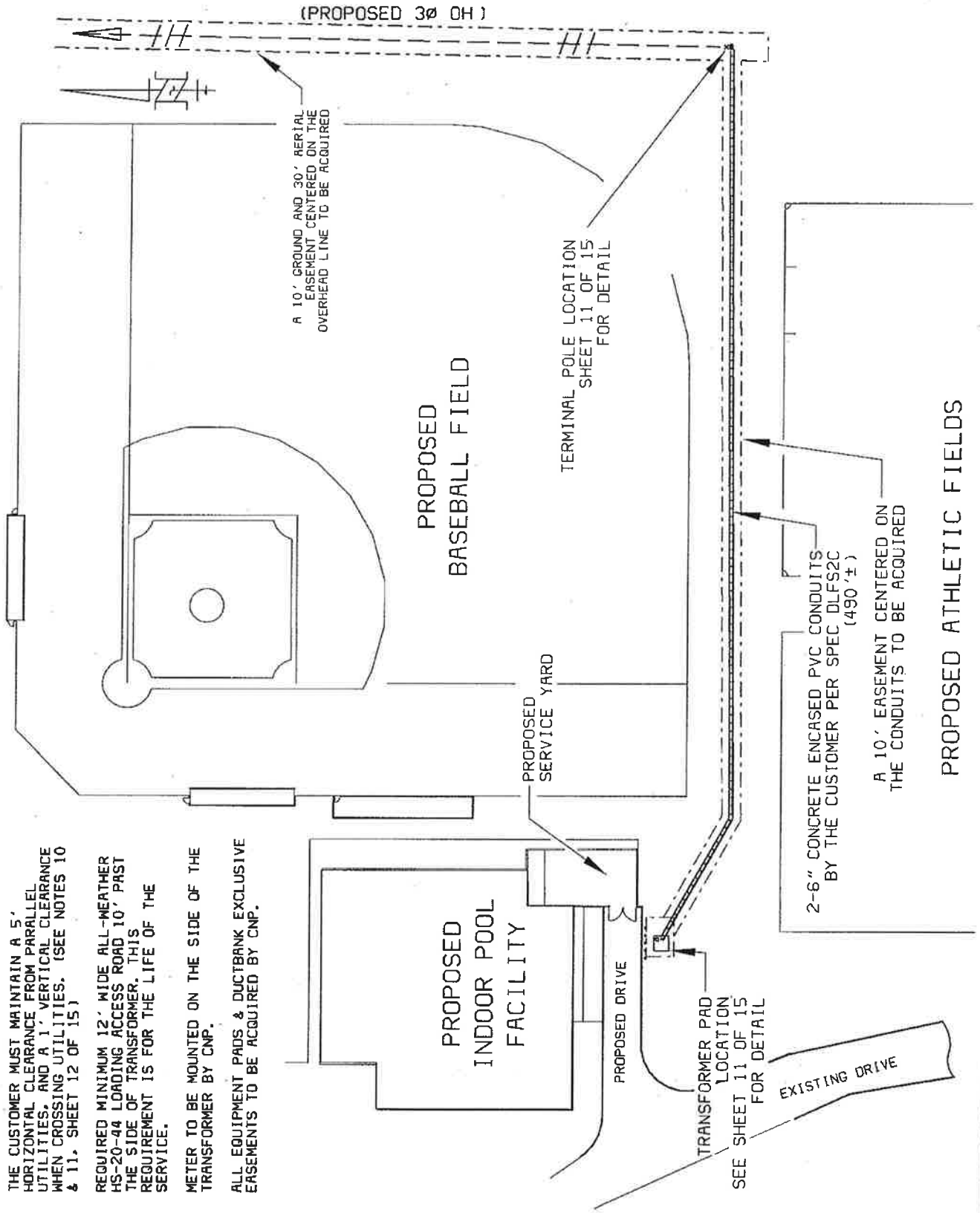

NOTES
CNP WILL NOT ALLOW OTHER FACILITIES TO PASS BENEATH ITS EQUIPMENT PAD.

THE CUSTOMER MUST MAINTAIN A 5' HORIZONTAL CLEARANCE FROM PARALLEL UTILITIES, AND A 1' VERTICAL CLEARANCE WHEN CROSSING UTILITIES. (SEE NOTES 10 & 11, SHEET 12 OF 15)

REQUIRED MINIMUM 12' WIDE ALL-WEATHER HS-20-44 LOADING ACCESS ROAD 10' PAST THE SIDE OF TRANSFORMER. THIS REQUIREMENT IS FOR THE LIFE OF THE SERVICE.

METER TO BE MOUNTED ON THE SIDE OF THE TRANSFORMER BY CNP.

ALL EQUIPMENT PADS & DUCTBANK EXCLUSIVE EASEMENTS TO BE ACQUIRED BY CNP.

GENERAL LOCATION SKETCH

LAMBERT	SECTION	KEY MAP	FUNCTIONAL LOCATION	SCALE	CIRCUIT	ORDER NO.
4357	C2	564L	-	N. T. S.	BV41	-

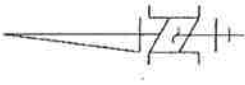

TERMINAL POLE
&
TRANSFORMER PAD
DETAILS

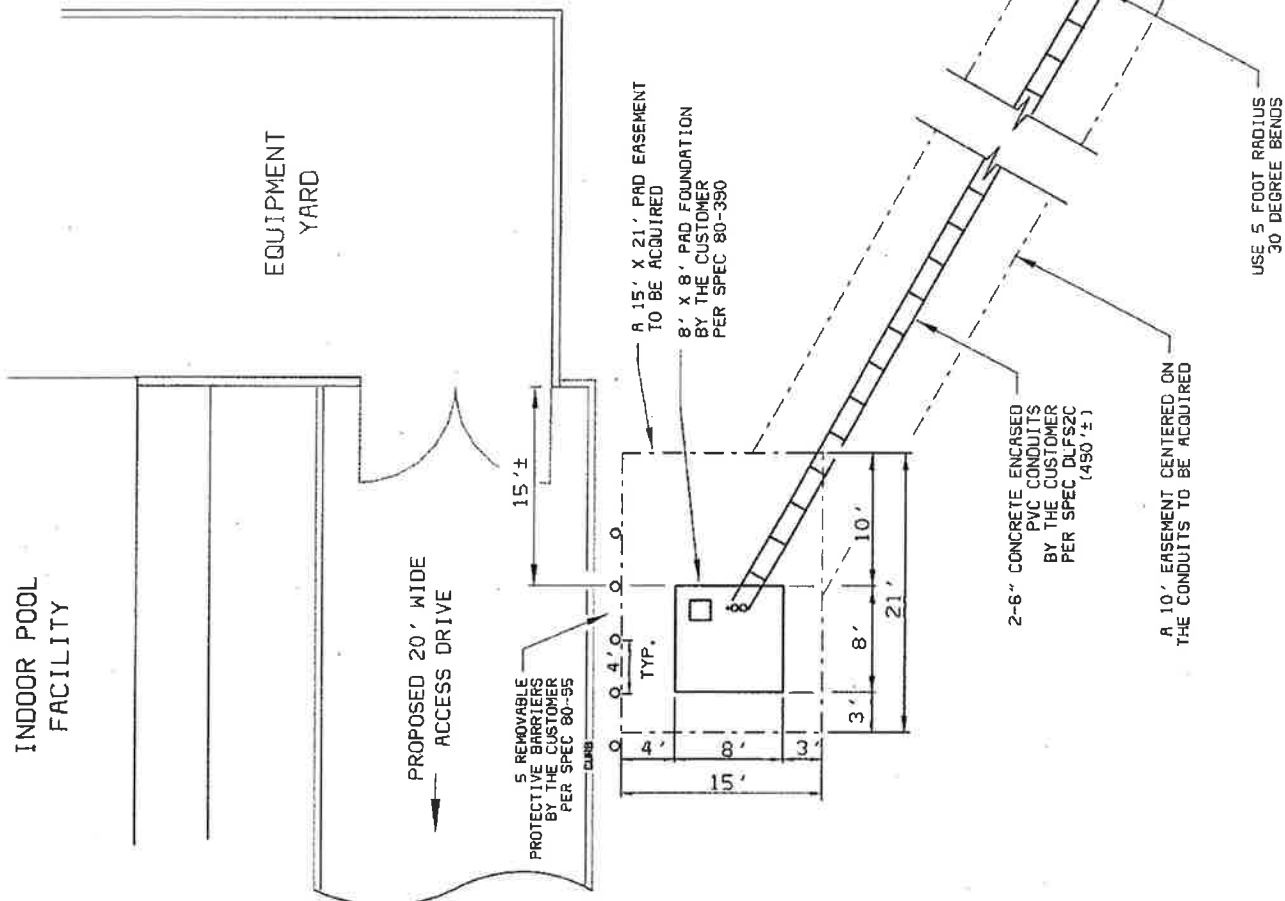

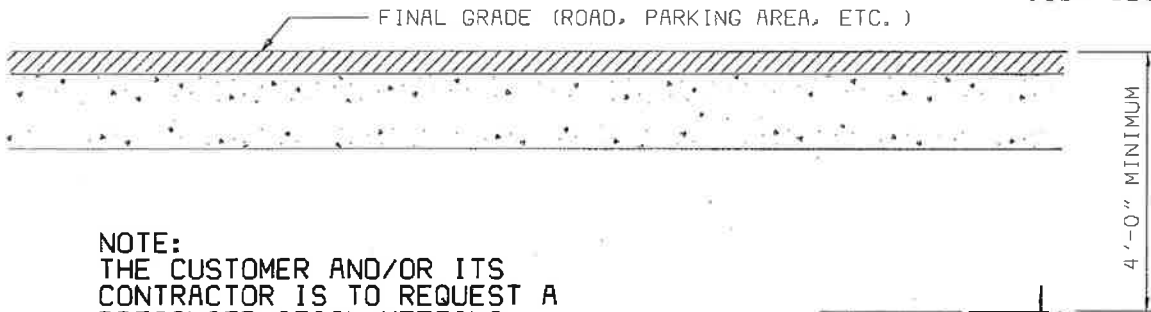

NOTE:
THE CUSTOMER AND/OR ITS
CONTRACTOR IS TO REQUEST A
PRECONSTRUCTION MEETING
PRIOR TO STARTING
CONSTRUCTION BY CALLING
(713) 207-6229.

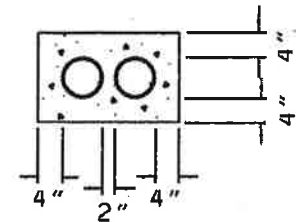

2 - 6" CONDUITS

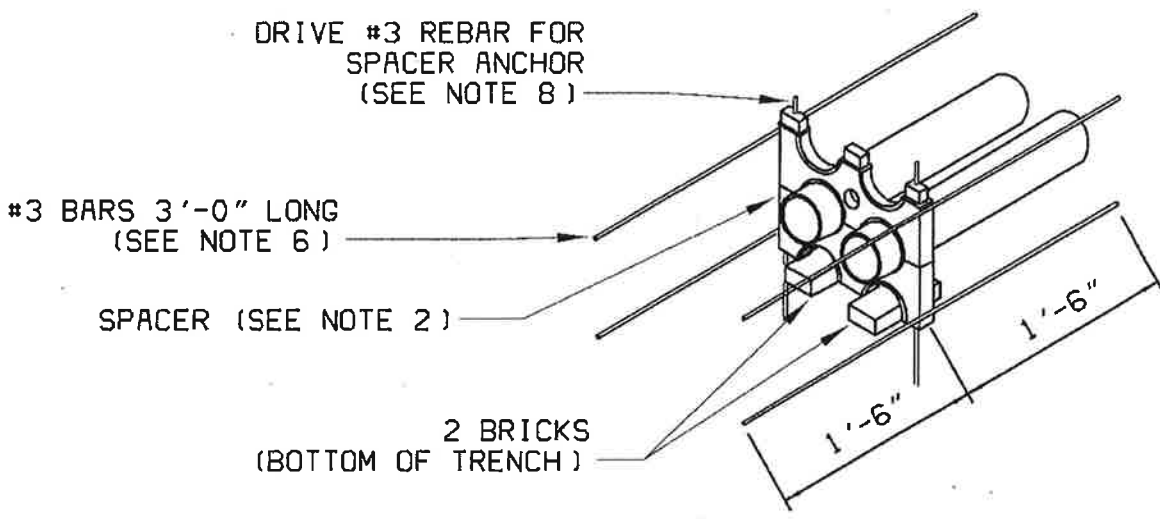

DRIVE #3 REBAR FOR
SPACER ANCHOR
(SEE NOTE 8)

#3 BARS 3'-0" LONG
(SEE NOTE 6)

SPACER (SEE NOTE 2)

2 BRICKS
(BOTTOM OF TRENCH)

NOTES:

1. CONDUIT TO BE PVC, MINIMUM GRADE TYPE EB.
2. SPACERS SHOULD BE INSTALLED NOT MORE THAN 10'-0" APART.
3. CONDUITS TERMINATING AT MANHOLES SHOULD BE SLOPED 0.5% DOWN TOWARD MANHOLE.
4. ALL EXTERIOR CONCRETE COVER DIMENSIONS ARE MINIMUM.
5. CONCRETE SHALL BE IN ACCORDANCE WITH CNP SPECIFICATION 007-221-01, LATEST REVISION.
6. PLACE REINFORCING BARS IN 4 CORNERS OF THE CONCRETE WHERE SPACERS ARE USED.
7. ON COLD JOINT CONCRETE POUR USE #5 REBAR (3'-0" IN LENGTH, EXPOSED 1'-6").
8. LENGTH OF REBAR FOR SPACER ANCHOR WILL VARY PER DUCT BANK HEIGHT.
9. CONDUITS ENDS SHALL BE PLUGGED WITH A DUCT CAP OR OTHER TYPE OF CAPPING DEVICE.
10. A ONE FOOT (1') VERTICAL CLEARANCE MUST BE MAINTAINED BETWEEN CNP'S DUCTBANK AND ALL NON-CNP FACILITIES CROSSING THE DUCTBANK.
11. A FIVE FOOT (5') HORIZONTAL CLEARANCE MUST BE MAINTAINED BETWEEN CNP'S DUCTBANK AND ALL NON-CNP FACILITIES RUNNING PARALLEL TO THE DUCTBANK (JOINT TRENCHING NOT PERMITTED).
12. INSTALL JET LINE IN ALL CONDUITS AND A #14 AWG WIRE IN ONE CONDUIT.

THREE PHASE DUCTBANK
FEEDER

BASED ON DISTRIBUTION STANDARD DLFS2C

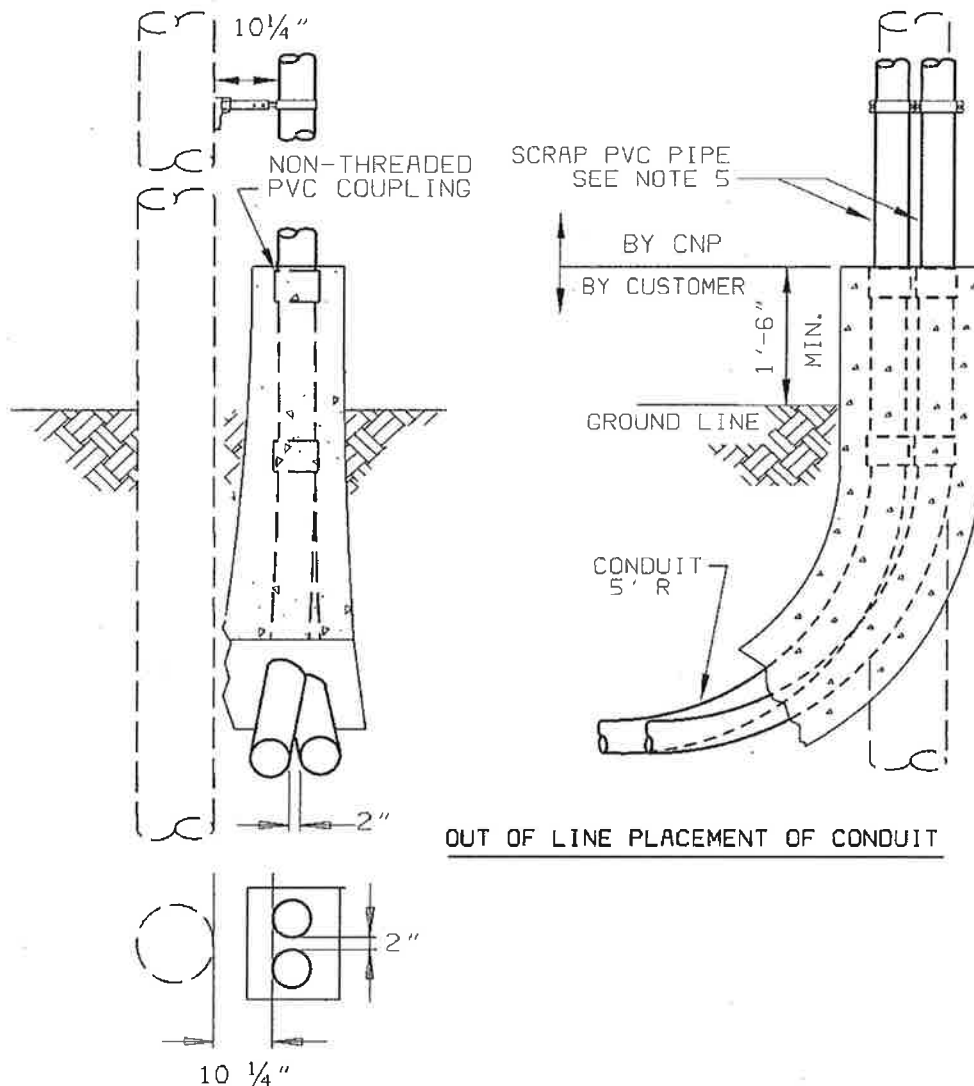

NOTES:

1. CONDUIT BENDS AT TERMINAL POLE SHALL BE PVC.
2. BRACE THE POLE SECURELY BEFORE TRENCHING.
3. INSTALL CONDUIT BENDS TO BASE OF POLE. ADD PORTIONS OF STRAIGHT CONDUIT AS NECESSARY TO OBTAIN THE PROPER HEIGHT ABOVE FINAL GRADE.
4. ATTACH COUPLING TO END OF CONDUIT.
5. INSERT, **BUT DO NOT GLUE**, A SHORT PIECE OF SCRAP PVC BUT DO NOT GLUE CONDUIT INTO THE TOP COUPLING. TIE CONDUIT TO BRACKET.
6. FORM AREA AROUND PEDESTAL TO THE TOP OF THE COUPLING. FORM PEDESTAL SO THAT NO CONCRETE WILL CONTACT POLE.
7. AFTER INSPECTION BY CNP, POUR CONCRETE TO TOP OF COUPLINGS.
8. ALL CONDUITS SHALL HAVE A MINIMUM 4" CONCRETE COVER.

TERMINAL POLE CONDUIT
PLACEMENT 12KV & 35 KV
BASED ON DISTRIBUTION STANDARD 65-500

0319866/100207

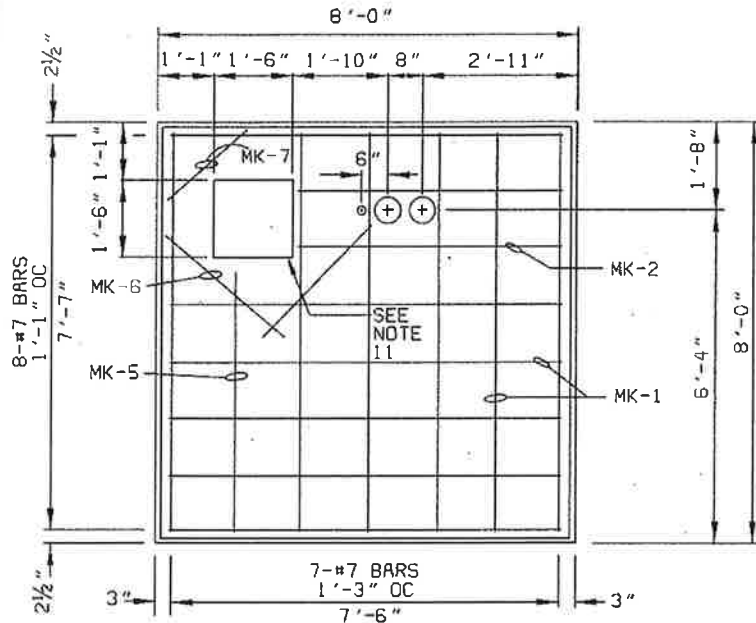

PLAN

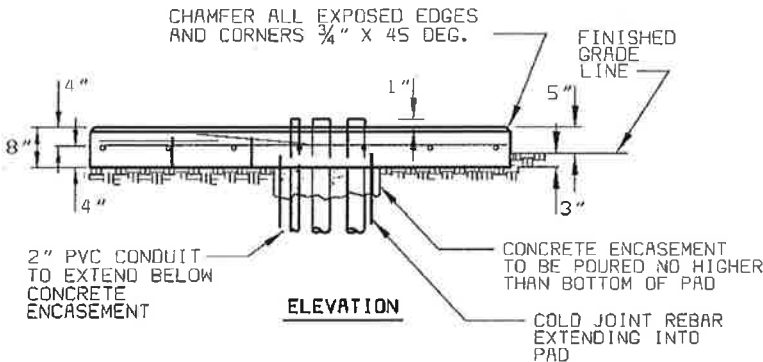

ELEVATION

REINFORCING SCHEDULE PER FOUNDATION				
MARK	QTY.	SIZE	LENGTH	REMARKS
MK-1	12	#7	7'-7"	STRAIGHT
MK-2	2	#7	5'-0"	STRAIGHT
MK-3	0	#7	2'-4"	STRAIGHT
MK-4	0	#7	5'-0"	STRAIGHT
MK-5	1	#7	4'-6"	STRAIGHT
MK-6	2	#7	3'-0"	STRAIGHT
MK-7	1	#7	2'-0"	STRAIGHT

MATERIAL ESTIMATE PER FOUNDATION	
DESCRIPTION	QTY.
REINFORCING STEEL #7	232 LBS
CONCRETE (5 SACK)	1 3/4 CU. YDS.
2" PVC CONDUIT	5 FT
TYPE EB OR BETTER PVC CONDUIT, 90 DEG, 80" R	2

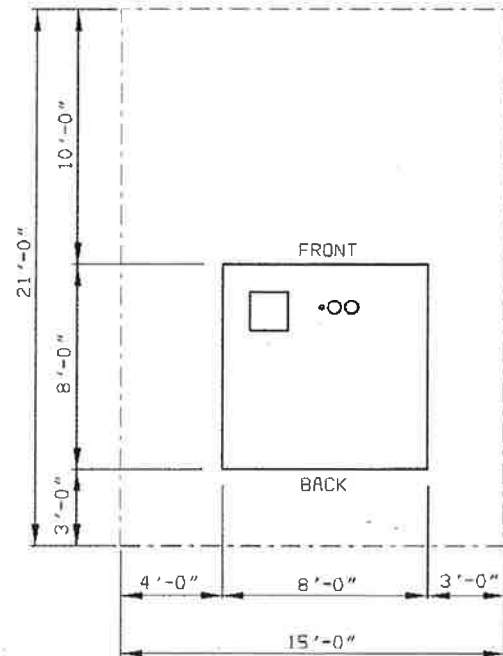

MINIMUM EASEMENT REQUIREMENTS

EQUIPMENT WEIGHT
20,000 LBS
MAXIMUM

NOTES:

1. CONCRETE SHALL BE IN ACCORDANCE WITH CNP SPECIFICATION 007-221-01, LATEST REVISION (MINIMUM COMPRESSION IN 28 DAYS, 3000 PSI).
2. REINFORCING STEEL SHALL BE INTERMEDIATE GRADE DEFORMED BARS IN ACCORDANCE WITH A.S.T.M. SPECIFICATION A-615, GRADE 60, OR BETTER.
3. ALL SPLICES IN REINFORCING SHALL LAP A LENGTH EQUAL TO 24 BAR DIAMETERS.
4. ALL DIMENSIONS ON REINFORCING ARE TO THE CENTER OF BARS.
5. CONCRETE SHALL BE THOROUGHLY WORKED AROUND REINFORCING, ANY EMBEDDED FIXTURES AND INTO ALL CORNERS OF FORMS.
6. IF REQUIRED, GROUT SHALL BE A MIXTURE OF 1 PART CEMENT TO 2 PARTS SAND WITH ENOUGH WATER TO PRODUCE A WORKABLE MIXTURE.
7. CONCRETE IS TO BE POURED ONLY WHEN THE ATMOSPHERIC TEMPERATURE IS A MINIMUM 40° F. AND RISING.
8. STRIP BACK ALL VEGETATION AND APPROXIMATELY 3" OF TOP SOIL. REMOVE ALL LOOSE CLODS AND STONES. BACKFILL AND THOROUGHLY COMPACT ALL CONDUIT TRENCHES AND HOLES BEFORE CONCRETE IS PLACED.
9. REINFORCING SHALL HAVE A MINIMUM OF 2 1/2" CONCRETE COVER.
10. SLOPE PAD 1" FRONT TO BACK.
11. THE SQUARE OPENING IS FOR THE CUSTOMER'S SECONDARY CONDUITS.
12. CNP WILL NOT ALLOW OTHER FACILITIES TO PASS BENEATH ITS EQUIPMENT PADS. A ONE FOOT MINIMUM HORIZONTAL CLEARANCE SHALL BE MAINTAINED BETWEEN CNP PADS AND ALL OTHER FACILITIES.
13. THE SECONDARY OPENING IS TO BE BACKFILLED WITH SAND TO WITHIN 4" OF THE TOP OF THE PAD.

150-1000 KVA, 3 PHASE
PMT FOUNDATION, 12KV & 35 KV
(SPECIAL APPLICATION)

BASED ON DISTRIBUTION STANDARD 80-390

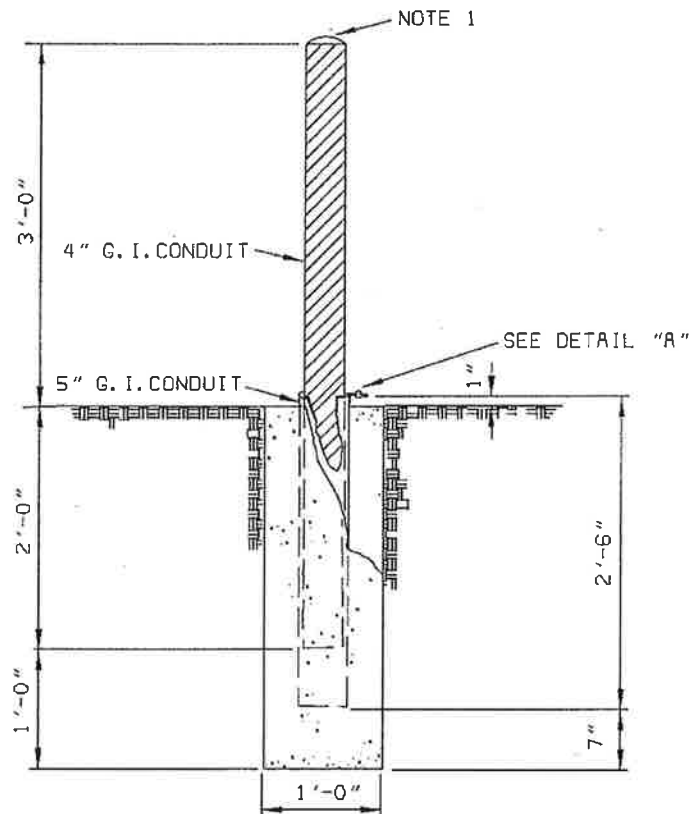
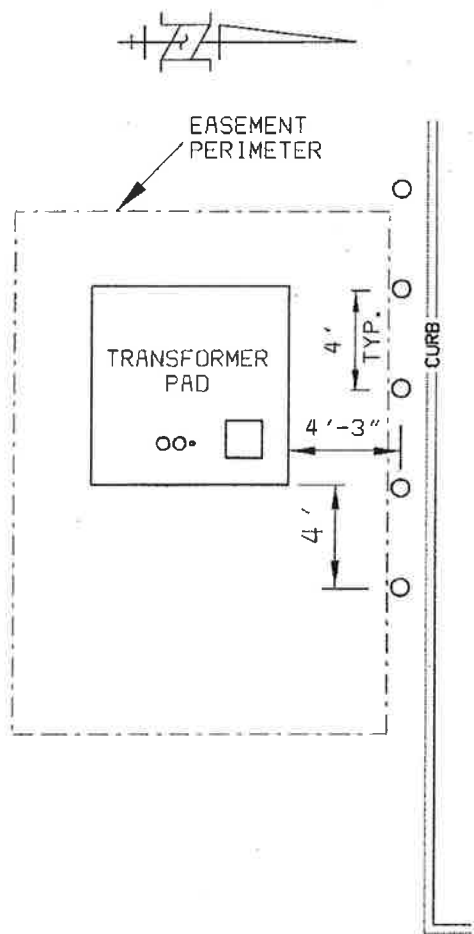

PROTECTIVE BARRIER
(REMOVABLE)

INSTALL FIVE (5)
REMOVABLE POST BARRIERS
ON APPROXIMATELY 4' CENTERS

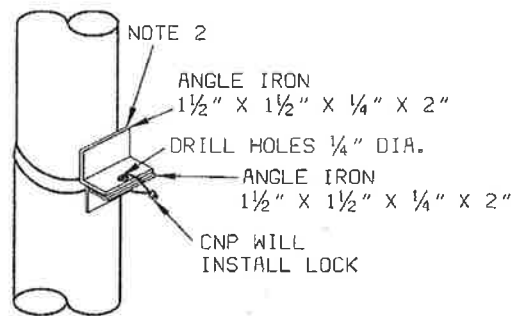

DETAIL "A"

NOTES:

1. 4" G.I. CONDUIT TO BE FILLED WITH CONCRETE.
2. ANGLE TO BE WELDED TO G.I. CONDUIT. ALL EXPOSED METAL TO BE PAINTED WITH GALVANOX PAINT.
3. SEAL GAP BETWEEN CONDUITS WITH DUCT SEAL FOR WATER TIGHT FIT.
4. USE 5" PLUG TO PREVENT CONCRETE FROM COMING UP 5" G.I. CONDUIT.

PROTECTIVE BARRIER
(REMOVABLE)

BASED ON DISTRIBUTION STANDARD 80-950

ADDENDUM TO "TERMS AND CONDITIONS TO UNDERGROUND ELECTRIC SERVICE"

This Addendum is dated as of the Effective Date (as defined below) and is between CENTERPOINT HOUSTON ELECTRIC, LLC (the "Company") and Lamar Consolidated I.S.D. ("Customer"). The Company and Customer are referred to in this Addendum individually as a "Party" and collectively as the "Parties."

Customer is the owner and operator of Briscoe Junior High School Practice Pool, 4300 FM 723 Rd. PP, Richmond, Texas 77406 ("Property"). ("Facilities") shall mean any facilities, equipment, cable, or other material referred to in the Agreement installed and owned by the customer or his contractor at **4300 FM 723 Rd. PP, Richmond, Texas 77406**.

Contemporaneously with the execution of this Addendum, Customer and the Company are entering into THE TERMS AND CONDITIONS TO UNDERGROUND ELECTRIC SERVICE (the "Agreement") under which underground electric service will be provided to the Facility. "Effective Date" means the date that the Agreement is signed, as indicated by the date next to the customer signature on the cover sheet of the Agreement.

Because of certain laws and regulations applicable to Customer, the Parties desire to set forth their understanding regarding those laws and regulations and the related allocation of certain risks and liabilities between them.

The Parties therefore agree as follows:

1. Applicability. This Addendum is being executed in connection with and will be deemed to be a part of the Agreement. No provision of the Agreement stating that the Agreement contains the entire understanding of the Parties with respect to its subject matter or other provision in the Agreement of the type typically referred to as a "merger clause" will apply to this Addendum. To the extent that the terms and provisions of this Addendum conflict with the terms and provisions of the Agreement, the terms and provisions of this Addendum control. Notwithstanding the execution of this Addendum, the Agreement remains in full force and effect, except as otherwise provided in this Addendum.

2. Customer as Governmental Entity. Customer represents and warrants that it is a governmental entity, and that as a governmental entity it is subject to constitutional and statutory limitations on its ability to be bound by certain terms and conditions of the Agreement, which may include terms and conditions relating to: liens on government property; disclaimers and limitations of warranties; disclaimers and limitations of liability for damages; waivers, disclaimers, and limitations on legal rights, remedies, requirements, commitment of future funding, and processes; limitations of time in which to bring legal action; control of litigation or dispute resolution; indemnities; and confidentiality of information, and to the extent that any provisions of the Agreement, including this Addendum, would violate any such restrictions, the Customer will not be bound by such provisions. Any terms or provisions of this Addendum that are less restrictive than those in the Agreement with respect to Customer's obligations will be null and void and will have no force or effect if the representation and warranty that Customer is a governmental entity is not true or to the extent that the more restrictive term in the Agreement

would be enforceable against Customer under Applicable Laws (as defined below). Terms and conditions in the Agreement relating to limitations of the type described in this section will only be binding on Customer to the extent they are valid and enforceable under all applicable laws, including all state and federal laws, rules and regulations, the constitutions of the United States and the State of Texas and the laws of the United States and the State of Texas ("Applicable Laws").

3. Maintenance. Except to the extent expressly set forth in a written agreement between the Parties, the Company will not be required to maintain equipment, cable, or other material that is owned by Customer. Customer acknowledges that it is Customer's sole responsibility to follow the proper administrative or internal procedures to cause its Facilities and any related equipment to be properly maintained. Customer also acknowledges that Company reserves the right, in accordance with Company Tariff, to discontinue service if Customer has failed, or the Company has determined, in its sole discretion, that Customer has failed, to maintain the Property and facilities or any related equipment, cable or other material in a manner that causes or could cause a safety hazard to person or property.

4. Installation. Customer understands that all facilities, equipment, cable and other material referred to in the Agreement must comply with all specifications set forth in said Agreement and the Permanent Easement and/or Right to Pull before the Company installs any equipment or provides electrical service. During the installation of any equipment to be installed by the Company under the Agreement, the Company will use every effort to preserve Customer's landscaping, parking areas, or other facilities. However, any cost that has been quoted to Customer does not include any special replacements or repairs to these items. The Company shall not be responsible for any expenses associated with replacements or repairs to Customer's property, and Customer hereby waives any claims for such expenses that it has or may have against the Company.

5. INDEMNIFICATION. This indemnity is pursuant to Company's Tariff located on our website at www.centerpointenergy.com. CUSTOMER ASSUMES THE RISK OF AND SHALL INDEMNIFY COMPANY AGAINST DAMAGES FOR INJURIES OR DEATH TO PERSONS OR LOSS TO CUSTOMER'S PROPERTY, OR TO THE PROPERTY OF COMPANY, WHEN OCCASIONED BY ACTIVITIES OF CUSTOMER OR THIRD PARTIES ON CUSTOMER'S PREMISES, RESULTING FROM THE INSTALLATION, EXISTENCE, REPLACEMENT, OR REPAIR OF COMPANY'S UNDERGROUND FACILITIES, AND AS FURTHER PROVIDED IN THE TERMS OF "LIMITS ON LIABILITY," SECTION 5.2 OF COMPANY'S TARIFF. NOTWITHSTANDING ANY OF THE ABOVE, THE PROVISIONS REQUIRING A CUSTOMER TO INDEMNIFY, FULLY PROTECT, OR SAVE COMPANY HARMLESS APPLY TO A GOVERNMENTAL ENTITY AS THIS TERM IS DEFINED IN CHAPTER 2251 OF THE TEXAS GOVERNMENT CODE, TO THE EXTENT OTHERWISE CONSISTENT WITH LAW; PROVIDED, HOWEVER, THAT ANY GOVERNMENTAL ENTITY THAT IS RECEIVING SERVICES UNDER THE AGREEMENT MUST TAKE NECESSARY STEPS TO ENSURE THAT THE INDEMNIFICATION REQUIREMENTS OF THIS SECTION DO NOT CREATE A "DEBT" IN VIOLATION OF ARTICLE XI, SECTION 7 OF THE TEXAS CONSTITUTION. SUCH STEPS MAY INCLUDE, BUT ARE NOT NECESSARILY LIMITED TO, A THIRD-PARTY INDEMNIFICATION IN WHICH THE

CONTRACTOR PERFORMING THE WORK FOR THE GOVERNMENTAL ENTITY INDEMNIFIES THE COMPANY OR THE ESTABLISHMENT OF A SINKING FUND. *SEE BROWN V. JEFFERSON COUNTY, 406 S.W.2D 185 (TEX. 1966).*

6. Further Assurances. If at any time after the date of this Addendum any further action is necessary or appropriate to carry out the purposes of this Addendum, Customer shall use all commercially reasonable efforts to take, or cause to be taken, that action.

7. Assignment. Customer shall not assign any part of its rights or delegate any performance under this Addendum, voluntarily or involuntarily, whether by merger, consolidation, dissolution, operation of law, or any other manner, without the Company's prior written consent. Any purported assignment of rights or delegation of performance in violation of this Section 7 is void and of no effect.

8. Modification; Waiver. No amendment of this Addendum will be effective unless it is in writing and signed by the Parties. No waiver of satisfaction of a condition or nonperformance of an obligation under this Addendum will be effective unless it is in writing and signed by the Party granting the waiver, and no such waiver will constitute a waiver of satisfaction of any other condition or nonperformance of any other obligation. To be valid, any document signed by a Party in accordance with this Section 8 must be signed by an officer or other representative of that Party authorized to do so.

In addition, nothing in this Addendum or the Agreement shall be construed as a waiver or relinquishment by the Company of any right that it has or may have hereafter to discontinue service for or on account of default in the performance of Customer's obligations under this Addendum or the Agreement, including payment of any bill owing or to become owing thereafter, or for any other reason or cause stated in the Company's Tariff.

[The remainder of this page has been intentionally left blank.]

The Parties are signing this Addendum as of the Effective Date.

COMPANY:

CENTERPOINT ENERGY HOUSTON
ELECTRIC, LLC

By:  _____

Name: Adewemimo A. Oyekenu, P. E.

Title: Supervising Engineer

CUSTOMER:

LAMAR CONSOLIDATED I.S.D.

By signing this Addendum, the person purporting to sign this Addendum on behalf of Customer is representing and warranting to the Company that the person has the legal authority to bind Customer and has been duly authorized by Customer to sign and deliver this Addendum to the Company.

By: _____

Name: James Steenbergen

Title: Board President

**CONSIDER APPROVAL OF CENTERPOINT ENERGY TERMS AND CONDITIONS
AND FACILITIES EXTENSION AGREEMENT FOR FULSHEAR HIGH SCHOOL
NATATORIUM**

RECOMMENDATION:

That the Board of Trustees approve the CenterPoint Energy terms and conditions and facilities extension agreement package for the installation of underground electric service at Fulshear High School Natatorium in the amount of \$19,200 and authorize the Board President to execute the agreement documents.

IMPACT/RATIONALE:

The terms and conditions are required to be executed for CenterPoint Energy to provide electric service for Fulshear High School Natatorium.

These funds were allocated within the 2014 Bond Budget.

PROGRAM DESCRIPTION:

Upon approval, the Board President will execute the agreement documents and CenterPoint Energy will begin design and installation of the permanent electrical service for Fulshear High School Natatorium.

Submitted By: Kevin McKeever, Administrator for Operations
Steve Hoyt, Vanir/Rice & Gardner Consultants, Inc., A Joint Venture

Recommended for approval:



Dr. Thomas Randle
Superintendent

CenterPoint Energy Houston Electric, LLC
Applicable: Entire Service Area

6.3 AGREEMENTS AND FORMS

6.3.1 FACILITIES EXTENSION AGREEMENT

This Facilities Extension Agreement is entered into by and between LAMAR CISD HIGH SCHOOL NO. 6 COMPLEX, herein called "Retail Customer" and CenterPoint Energy Houston Electric, LLC, herein called "Company" (hereinafter referred to as Agreement) for the construction, extension, installation, modification, repair, upgrade, conversion, relocation, de-energization or removal of Company's Delivery System, including temporary facilities (hereinafter referred to as facilities extension or extension), as described herein.

This Agreement covers the facilities extension to Retail Customer location at 9320 CHARGER WAY, FULSHEAR, TX.

The Company agrees to accept payment of \$19,200.00 Dollars to be paid by the Retail Customer, as a Non-Refundable Construction Payment in connection with the Retail Customer request to extend Company facilities to the above described location as follows: Installation of underground facilities, as detailed in the Terms and Conditions, Job #83165723. This agreement includes no cost for the extension, modification or removal of the existing overhead facilities. Please contact the Company's respective Service Center representative for any additional costs that may be associated with this project.

- Unless otherwise stated by Company in writing, the Non-Refundable Construction Payment amount above is valid for twelve months.

In consideration of said Non-Refundable Payment, to be paid to Company by Retail Customer prior to commencement of construction, Company agrees to install and operate lines and equipment necessary to distribute electric service to the identified location under the following General Conditions:

- Company shall at all times have title to and complete ownership and control over facilities installed by Company.
- Retail Customer must make satisfactory payment arrangements (if payment is required to extend Company facilities) and sign and return this Agreement before Company can proceed with the requested extension.

CenterPoint Energy Houston Electric, LLC
Applicable: Entire Service Area

- Extension of service facilities is contingent on acquisition of all necessary easements and rights of way.

Nothing herein contained within this Agreement shall be construed as a waiver or relinquishment by Company of any right that it has or may hereafter have to discontinue service for or on account of default in the payment of any bill owing or to become owing thereafter for any other reason or cause stated in Company's Tariff.

This Agreement shall not be binding upon Company unless and until it is signed by an authorized representative of the Company.

CenterPoint Energy Houston Electric, LLC

LAMAR CISD HIGH SCHOOL NO. 6
COMPLEX

Retail Customer

By _____

By _____

Signature

Latanya Joubert

James Steenbergen

Name printed or typed

Name printed or typed

Title Engineering Specialist

Title Board President

Date October 5, 2017

Date _____

GENERAL

A. These Terms and Conditions are for a service arrangement for LAMAR CISD HIGH SCHOOL NO. 6 COMPLEX. LAMAR CISD HIGH SCHOOL NO. 6 COMPLEX and/or its contractors/representatives are herein referred to as the Customer.

B. Service to be provided by CenterPoint Energy (CNP) from a 500 kVA, 34.5 kV - 480Y/277 V, three phase, four wire, pad mounted transformer.

C. The CNP Major Underground Engineering (MUG) representative is Latanya Joubert at 713-207-6242 or LaTanya.Joubert@centerpointenergy.com.

The CNP Service Area Consultant is Benjamin J Kresta at 281-391-5114.

D. The Customer must comply with all CNP Service Standards, the National Electrical Code, the National Electrical Safety Code, all Occupational Safety and Health Administration (OSHA) requirements, the International Building Code and all local governing body codes.

E. During installation of CNP equipment, CNP will make every effort to preserve the Customer's landscaping, parking areas, or other facilities. However, any cost that has been quoted to the Customer does not include any special replacements or repairs to these items. The Customer shall be solely responsible for any expenses associated with replacements or repairs to its facilities.

F. The service arrangement outlined in these Terms and Conditions is based on the Customer drawings referenced on page 1. Any changes in the design as illustrated in the referenced drawings may impact CNP's ability to meet the Customer's requested service date.

G. Any changes, additions, deletions, rearrangements, relocations, rerouting, reduction of clearances, etc., of the Customer's and/or CNP's service facilities illustrated in these Terms and Conditions shall have MUG's approval and may require a revised Terms and Conditions. It is the Customer's responsibility to coordinate the location of all Customer installed facilities outlined in these Terms and Conditions with all other structures and/or appurtenances not shown in the referenced drawings.

H. Contact the MUG representative concerning Customer drawing revisions, information submission, questions, Terms and Conditions revision requests, etc.

I. Hard copy submittals may be mailed to the MUG representative (address – 3000A Harrisburg Blvd. – Houston, Texas 77003). Electronic submittals may be e-mailed to the MUG representative. The MUG representative will; “approve the submittals”, “approve the submittals as noted” or “not approve the submittals”. The Customer shall not install any item that requires CNP approval before receiving an official approval from MUG. CNP shall not be responsible for any installed item that has not received MUG approval.

SERVICE CONNECTION

- A. The Customer's maximum number of secondary cables that can be terminated in CNP's pad mount transformer is 8-750 MCM cables per phase. The Customer shall advise the MUG representative, about the type, size and number of secondary conductors. Ampacity equivalent sets of cable must be individually approved by the MUG representative prior to installation by the Customer. If the Customer's cable requirements exceed this specified maximum limit, it cannot be served directly from the pad mounted transformer. The Customer shall then install, own, and maintain a cable tap box (CTB) (See Section D).
- B. On installations not utilizing a CTB, the Customer shall furnish, own, and maintain all secondary service conduit and cable underground into the secondary opening of the transformer pad. Secondary conductors shall be extended a minimum of seven feet (7') above the transformer pad. **The Customer shall not install the secondary cables until after the transformer has been set. CNP will terminate the secondary cables in the transformer.**
- C. To accommodate future expansion, the Customer may install up to 8-4" secondary conduits into the transformer pad.
- D. On installations utilizing a CTB, CNP shall furnish, own, install and terminate the secondary cable from the transformer to the CTB at the Customer's expense. The Customer shall furnish, install, own and maintain the CTB, the CTB pad, and 4-4" conduits from the secondary opening of the transformer pad to the CNP side of the CTB pad. The Customer shall install and terminate the secondary cable from its side of the CTB to its switchgear. Typical three-phase CTB drawings are available upon request. The Customer shall submit three (3) drawings of the proposed CTB to the MUG representative for approval prior to fabrication.
- E. The initial available short circuit current is 34,366 amperes symmetrical, with an X/R ratio of 3.1.
- F. The ultimate available short circuit current is 34,366 amperes symmetrical, with an X/R ratio of 3.1.
- G. Customers receiving electrical service from multiple sources will be required to install a permanent plaque or directory at each source in accordance with Article 230.2 of the National Electrical Code (NEC). These plaques are to signify that there is more than one electrical service to the building. The Customer shall keep the power from each source separate throughout its entire electrical system. This requirement is for the life of the service.
- H. A protective device coordination study for the Customer's service relative to CNP's protective devices may be requested by contacting the MUG representative.

ACCESS

The Customer must provide a twelve foot (12') minimum width, fourteen foot (14') minimum vertical clearance, all weather, vehicle access road designed for HS-20-44 loading as recognized by the American Association of State Highway Officials (AASHO), for CNP personnel and equipment ten feet (10') past the side of the proposed pad mounted equipment location. In addition, the area adjacent to the pad must be designed for HS-20-44 loading to allow for outrigger placement. If the access road and the pad mounted equipment location have not been completed and passed final inspection (see Final Inspection, page 7) at the time the Customer requests the equipment be set, the equipment can only be set under the following conditions.

- A. MUG has determined that the access route is dry and readily accessible to CNP's normal installation equipment.
- B. The Customer shall be responsible for all expenses associated with the repair and/or replacement of CNP pad mounted equipment damaged by additional construction activity. Damage to CNP equipment may result in delays to the Customer's requested service date.
- C. CNP will not complete the underground construction (i.e. pulling & terminating cable, energizing the service, etc.) until the access road and pad mounted equipment location have passed final inspection (see Final Inspection, page 7).

The Customer must provide a thirty two foot (32') minimum vertical clearance over all equipment pads for CNP trucks and equipment.

The Customer must maintain these requirements for the life of the service.

CNP will utilize the Customer's parking and driveway facilities for the required access.

EMERGENCY GENERATION AND SECONDARY LOAD TRANSFER

Customer installed Emergency Generators and/or Secondary Load Transfer schemes shall meet the requirements of the CNP Specification on Customer Emergency Generation and Secondary Load Transfer, Specification 007-231-82, latest revision (attached). This requirement is for the life of the service.

Generator exhaust must be located and/or directed away from CNP's equipment.

HARMONIC DISTORTION

The Customer shall meet the requirements of the CNP Specification on Limitation of Harmonic Distortion on the Distribution System, Specification 007-231-83, latest revision (available upon request). This requirement is for the life of the service.

METERING

- A. The Customer's metering arrangement must comply with CNP Service Standards, Section 400 or 500 as applicable.
- B. The metering current and potential transformers (CT's and PT's) will be installed in the secondary compartment of the transformer provided all service from the transformer is through one meter. If all the services are not through one meter, the Customer shall inform the MUG representative, so that alternate metering provisions can be arranged (separate CT and PT cans as required for each service).
- C. All Retail Customers must be metered separately.
- D. Meter Room and/or Modular Meter installations must have CNP written approval prior to the purchase/installation of materials/equipment. The Customer must submit applicable drawings to the MUG representative for approval.

FACILITIES INSTALLED BY THE CUSTOMER

All facilities are to be installed per the attached construction specifications. The Customer or its contractor is to request a preconstruction meeting prior to starting the required underground construction by calling the number listed below.

All facilities shall be inspected by CNP after the conduit is installed, pads are formed, reinforcing rods installed, etc. but prior to the pouring of concrete. CNP recommends that the Customer complete the pouring of concrete on the day the facilities are inspected and approved. The Customer will insure that all inspected and approved facilities remain in the approved condition until the concrete pour has been completed. If there is damage to the inspected and approved facilities prior to the pouring of concrete, the facilities must be re-inspected by CNP before the Customer begins the pouring of concrete. CNP reserves the right to require the Customer to break out any unapproved concrete pours at its expense.

CNP will make a reasonable attempt to complete all inspection requests. To insure that inspection requests can be fulfilled, they should be made twenty-four (24) hours in advance (Mon. - Fri.; between 9:00 a.m. and 3:00 p.m., holidays excluded) to Major Underground Engineering at (713) 207-6229. Job # 83165723 must be provided as the inspection identification number.

DUCTBANK INSTALLATION

All proposed conduit for CNP's use is to be installed in straight runs, unless otherwise indicated on CNP drawings. Any conduit bends must be installed with a twenty foot (20') minimum radius, unless indicated otherwise on CNP drawings. Conduit turn-ups into any equipment pad and/or pole pedestal must have a minimum five foot (5') radius. Any deviations from these requirements shall have written approval from the MUG representative prior to installation.

During installation, the minimum depth for a conduit run must be referenced to the final grade.

The Customer is to delay installation of approximately the last twenty feet (20') of the conduit run and the pole pedestal to any terminal pole until the pole has been set by CNP. Before trenching to the base of any terminal pole, the Customer must securely brace the pole. The Customer must request staking and setting of any terminal pole by contacting the Service Area Consultant.

The Customer must provide a jet line in each conduit installed. This jet line shall extend a minimum of seven feet (7') beyond the end of each conduit.

DUCTBANK INSTALLATION (continued)

For installations not utilizing a blanket easement document (see Easement Instrument section, page 7), the Customer shall also install a #14 American Wire Gage (AWG) or larger aluminum or copper 600 volt insulated conductor in one of the conduits. The conductor must be electrically continuous. For manhole installations, the electrically continuous conductor must also be looped through each manhole lid and tied to a concrete insert in the neck of each manhole. This conductor is to facilitate surveying of the duct bank by CNP. The duct bank cannot be surveyed until this conductor is installed as prescribed. The Customer must take adequate measures to assure the conductor will be in place until all necessary surveying is completed. After surveying of the duct bank is completed, but prior to CNP installing any primary cable, the Customer may retrieve its conductor at its option.

Conduit ends shall be plugged with a duct cap or other type capping device. The use of rags to plug conduits is not acceptable. If the conduit is installed in stages, the Customer must keep each section of conduit capped until the new section is installed. If, prior to CNP using any conduit, the conduit is found to be blocked, the Customer will be responsible, at its expense, for removing the obstruction.

CLEARANCES

Final approval for the location of the pad mount equipment and/or other proposed electrical installation is contingent upon proper clearance, as determined by CNP, from cooling towers, vents, buildings, structures, etc., and other underground utilities. It is in the Customer's and CNP's best interest to have all service equipment in a contamination-free environment to avoid unscheduled outages and/or premature equipment failures. Therefore, prior to any construction, the Customer shall inform the MUG representative of any existing or future contamination or pollutants which may affect the equipment so that necessary clearances can be secured.

The MUG representative shall be notified promptly if the Customer intends to install any obstructions such as walls, hedges, bushes, trees, etc., around the transformer and/or any associated equipment so that additional clearances and access can be secured. Any proposed enclosure surrounding CNP's equipment must be louvered, and both a profile and a cross-sectional view of the proposed louvered enclosure shall be submitted for approval prior to installation.

If, in the future, there is a problem with contamination of CNP's equipment, or proper clearances are not maintained, CNP reserves the right to relocate the equipment at the Customer's expense.

CNP will not allow other facilities to pass beneath its equipment pads. A one foot (1') minimum horizontal clearance shall be maintained between CNP pads and all other facilities.

A one foot (1') minimum vertical clearance must be maintained between CNP duct banks and all non-CNP facilities crossing the duct bank.

A five foot (5') minimum horizontal clearance must be maintained between CNP duct banks and other facilities running parallel to the duct bank. CNP will not allow joint trenching between CNP duct banks and other facilities.

ELEVATION REQUIREMENTS

The minimum elevation requirement for the top of the equipment pads shall be fifteen (15) feet above mean sea level or eighteen (18) inches above the documented 100 year floodplain, whichever is greater. The Customer must provide equipment pads that meet these elevation requirements. The easement (minimum working clearance) around the equipment pads shall also be brought up to the above mentioned minimum elevation, as outlined on the equipment pad detail specification. The easement area surrounding the equipment pads shall not have a slope greater than 2%. The pad and minimum easement elevations (minimum working clearance) must be verified at the time installation.

VENTILATION REQUIREMENTS

Any proposed barriers or enclosures in the vicinity of the equipment pads shall maintain a minimum of 50% free air flow. Prior to construction, the Customer shall submit drawings of the proposed barriers or enclosures to MUG Engineering Representative for approval.

FINAL INSPECTION

After the Customer has advised CNP that all "Customer installed" facilities pertaining to this service arrangement have been completed and inspected, a final on-site inspection will be made by a MUG representative. This final inspection will verify that all Customer installed facilities are in accordance with these Terms and Conditions. The Customer (or its contractor) and the Service Area Consultant will be advised of any needed corrections and/or changes. When all necessary corrections and/or changes have been completed, CNP's portion of the construction may begin.

EASEMENT INSTRUMENT

CNP will prepare an instrument for easements to be granted by the property owner after all installations for CNP's use have been completed according to these Terms and Conditions. The service cannot be energized until CNP has accepted the signed instrument for all easements.

The Customer also has the option of signing a blanket easement document. Use of the blanket easement allows the service to be energized before the final signed instrument for all easements has been completed. The Customer may request use of the blanket easement document by contacting the MUG representative.

CNP will need access to and from the proposed easements. CNP will use these easements, as shown on the attached sketches, for the purposes of erecting, installing, operating, maintaining, replacing, inspecting and removing electrical distribution facilities. The Customer shall keep these easements free and clear of any obstructions (trees, shrubs, other structures, etc.) that may endanger or interfere with the efficiency, safety, and proper operation of the proposed facilities for the life of the service.

INDEMNIFICATION AND LIABILITY LIMITS

Indemnity: This indemnity is pursuant to Company's Tariff located on our website at www.centerpointenergy.com.

RETAIL CUSTOMER ASSUMES THE RISK OF AND SHALL INDEMNIFY COMPANY AGAINST DAMAGES FOR INJURIES OR DEATH TO PERSONS OR LOSS TO RETAIL CUSTOMER'S PROPERTY, OR TO THE PROPERTY OF COMPANY, WHEN OCCASIONED BY ACTIVITIES OF RETAIL CUSTOMER OR THIRD PARTIES ON CUSTOMER'S PREMISES, RESULTING FROM THE INSTALLATION, EXISTENCE, REPLACEMENT, OR REPAIR OF COMPANY'S UNDERGROUND FACILITIES, AND AS FURTHER PROVIDED IN THE TERMS OF "LIMITS ON LIABILITY," SECTIONS 4.2 AND 5.2 OF THIS TARIFF. NOTWITHSTANDING ANY OF THE ABOVE, THE PROVISIONS REQUIRING A RETAIL CUSTOMER TO INDEMNIFY, FULLY PROTECT, OR SAVE COMPANY HARMLESS APPLY TO A GOVERNMENTAL ENTITY AS THIS TERM IS DEFINED IN CHAPTER 2251 OF THE TEXAS GOVERNMENT CODE, TO THE EXTENT OTHERWISE CONSISTENT WITH LAW; PROVIDED, HOWEVER, THAT ANY GOVERNMENTAL ENTITY THAT IS A RETAIL CUSTOMER TO WHICH THIS SUBSECTION 2.5 APPLIES MUST TAKE NECESSARY STEPS TO ENSURE THAT THE INDEMNIFICATION REQUIREMENTS OF THIS SUBSECTION 2.5 DO NOT CREATE A "DEBT" IN VIOLATION OF ARTICLE XI, SECTION 7 OF THE TEXAS CONSTITUTION. SUCH STEPS MAY INCLUDE, BUT ARE NOT NECESSARILY LIMITED TO, A THIRD-PARTY INDEMNIFICATION IN WHICH THE CONTRACTOR PERFORMING THE WORK FOR THE GOVERNMENTAL ENTITY INDEMNIFIES THE COMPANY OR THE ESTABLISHMENT OF A SINKING FUND. (*See Governmental Entity Addendum if applicable.*)

GENERAL LOCATION SKETCH

LAMBERT	SECTION	KEY MAP	FUNCTIONAL LOCATION	SCALE	CIRCUIT	ORDER NO.
4154	B3	523E		N. T. S.	FL42	

LAMAR CISD HIGH SCHOOL NO.6 COMPLEX (CUSTOMER)
AND/OR ITS CONTRACTOR IS TO
REQUEST A PRECONSTRUCTION MEETING
PRIOR TO STARTING CONSTRUCTION BY
CALLING (713) 207-6229

CENTERPOINT ENERGY (CNP) TO UTILIZE
THE CUSTOMER'S PARKING AND DRIVEWAY
FACILITIES FOR EQUIPMENT ACCESS

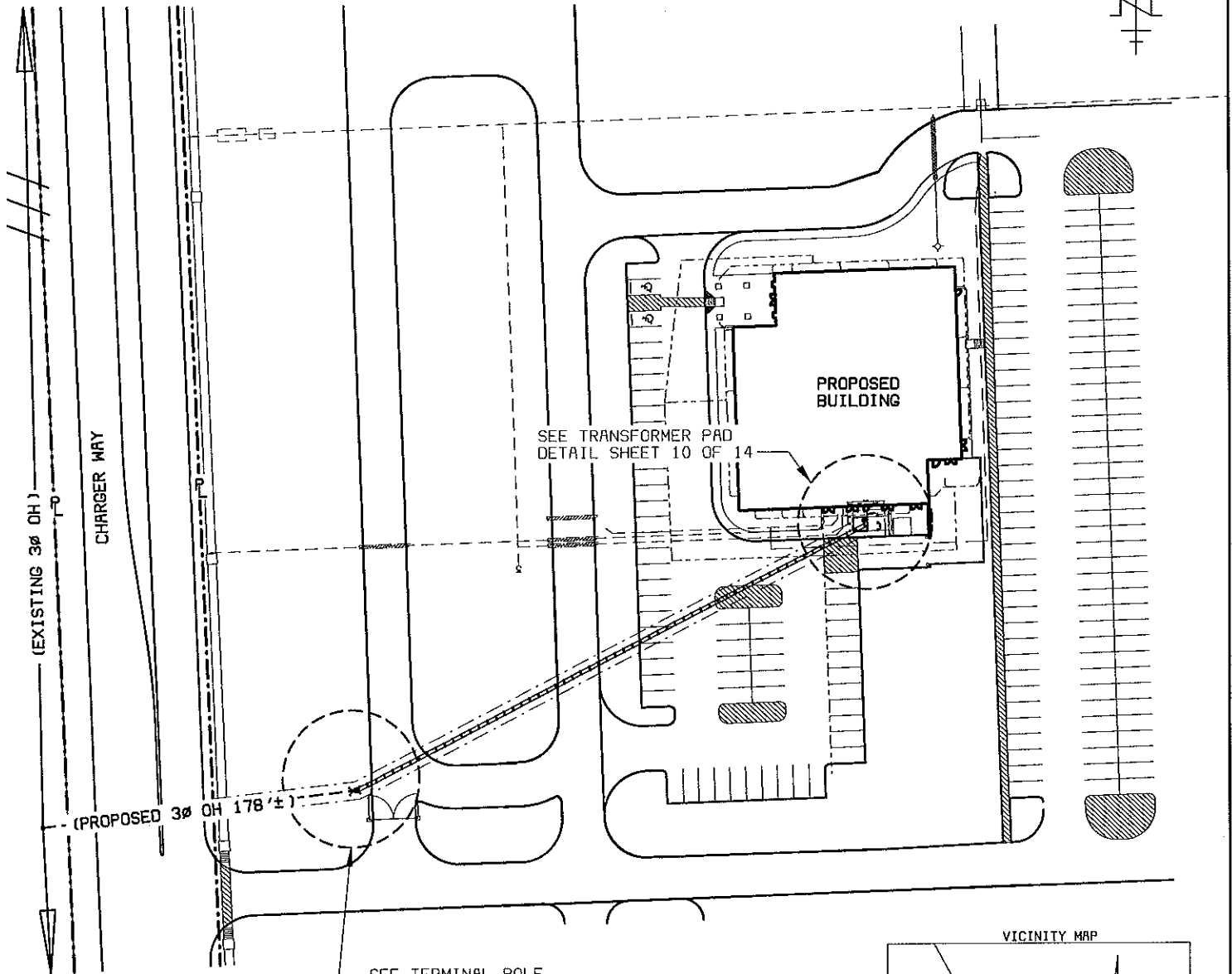
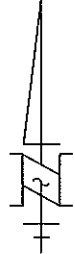

SEE TERMINAL POLE
DETAIL SHEET 10 OF 14

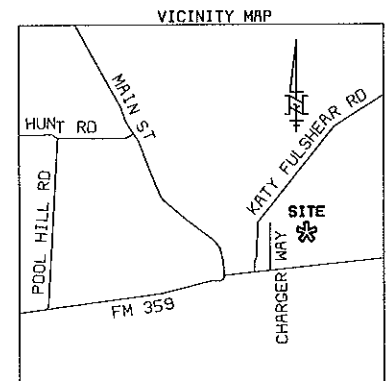

DETAIL SKETCH

LAMBERT	SECTION	KEY MAP	FUNCTIONAL LOCATION	SCALE	CIRCUIT	ORDER NO.
4154	B3	523E		N. T. S.	FL.42	

TRANSFORMER PAD DETAIL

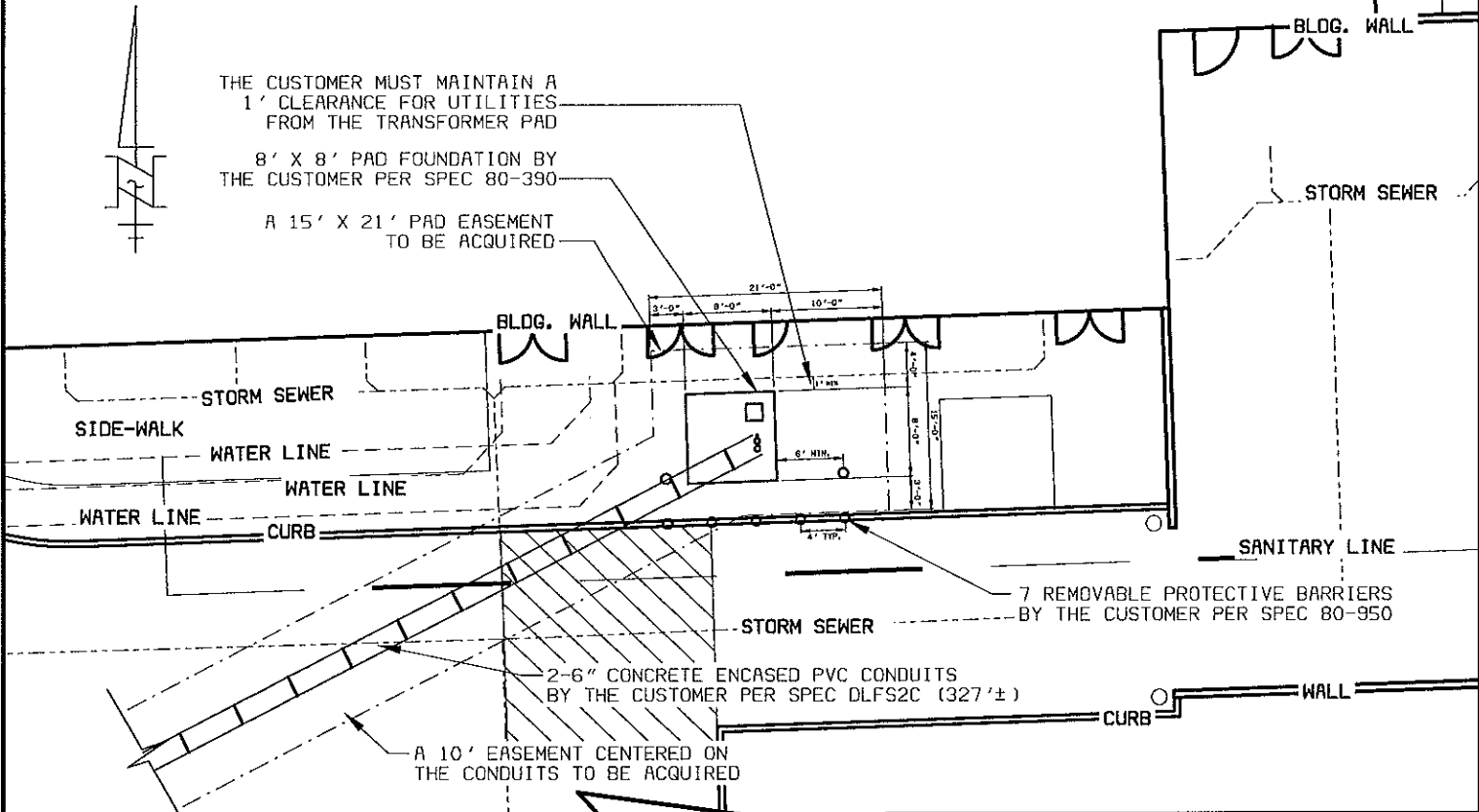

NOTES
 CNP WILL NOT ALLOW OTHER FACILITIES TO PASS BENEATH ITS EQUIPMENT PAD.
 THE CUSTOMER MUST MAINTAIN A 5' HORIZONTAL CLEARANCE FROM PARALLEL UTILITIES, AND A 1' VERTICAL CLEARANCE WHEN CROSSING UTILITIES. (SEE NOTES 10 & 11, SHEET 11 OF 14)
 REQUIRED MINIMUM 12' WIDE ALL-WEATHER HS-20-44 LOADING ACCESS ROAD 10' PAST THE SIDE OF TRANSFORMER. THIS REQUIREMENT IS FOR THE LIFE OF THE SERVICE.
 METER TO BE MOUNTED ON THE SIDE OF THE TRANSFORMER BY CNP.
 ALL EQUIPMENT PADS & DUCTBANK EXCLUSIVE EASEMENTS TO BE ACQUIRED BY CNP.

TERMINAL POLE DETAIL

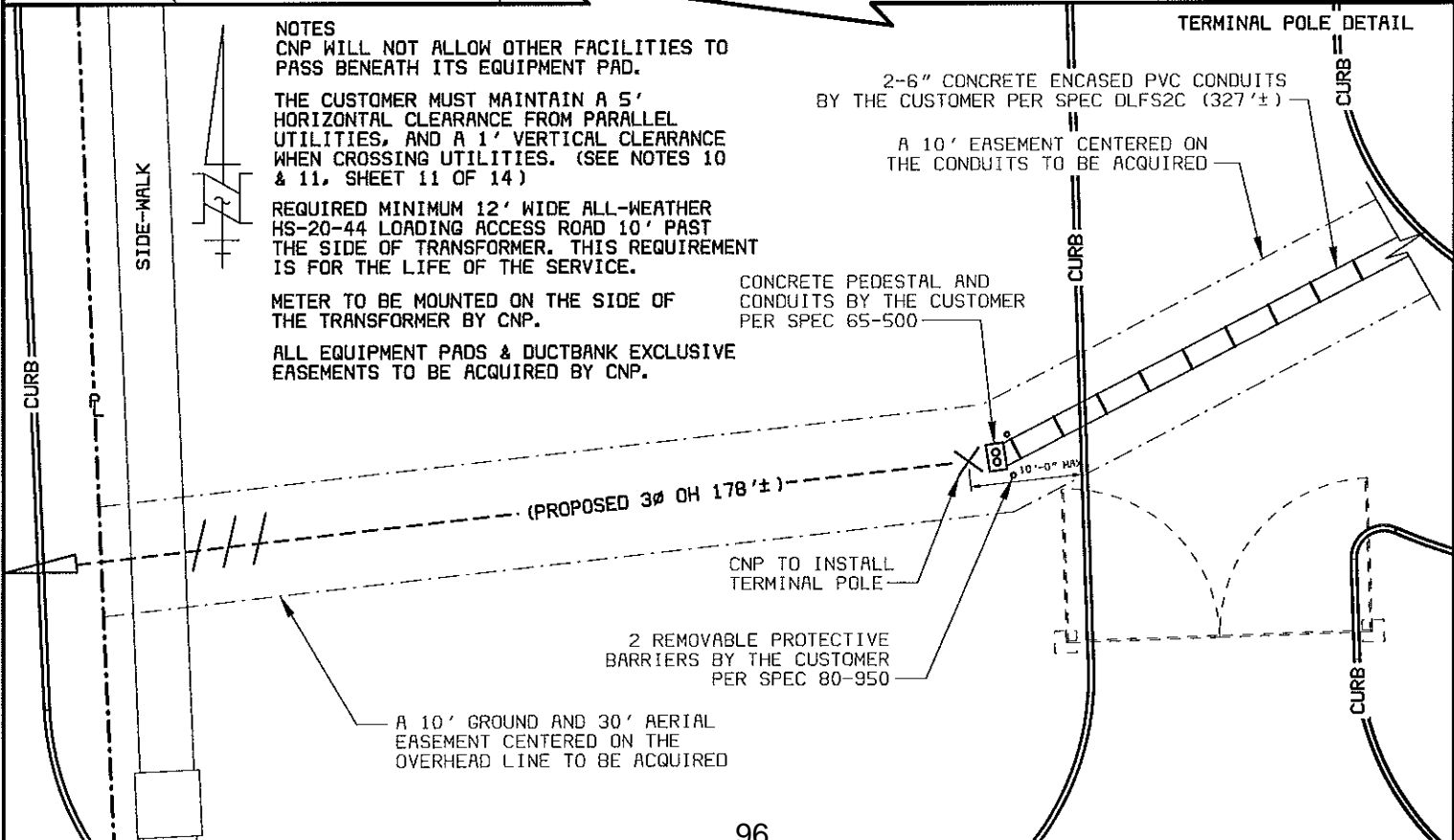

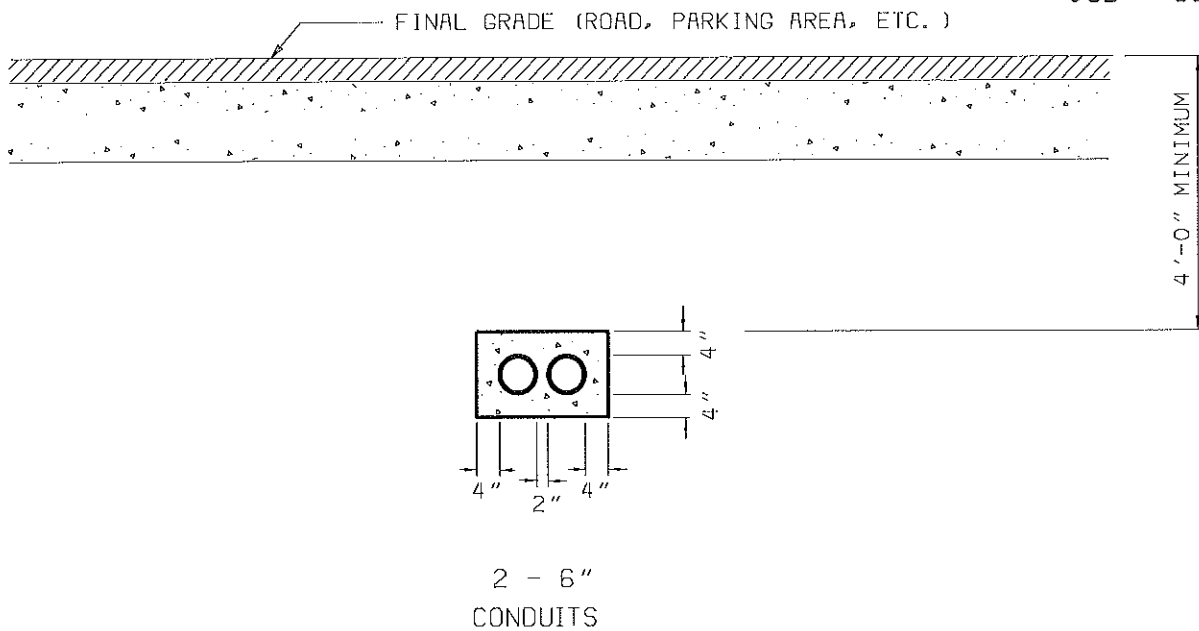

NOTE:
THE CUSTOMER AND/OR ITS CONTRACTOR
IS TO REQUEST A PRECONSTRUCTION MEETING
PRIOR TO STARTING CONSTRUCTION BY CALLING
(713) 207-6229.

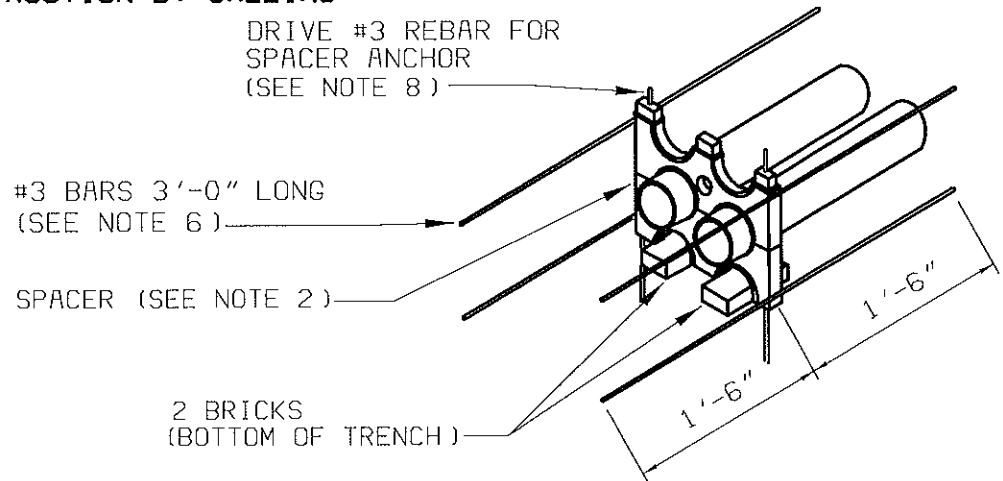

NOTES:

1. CONDUIT TO BE PVC, MINIMUM GRADE TYPE EB.
2. SPACERS SHOULD BE INSTALLED NOT MORE THAN 10'-0" APART.
3. CONDUITS TERMINATING AT MANHOLES SHOULD BE SLOPED 0.5% DOWN TOWARD MANHOLE.
4. ALL EXTERIOR CONCRETE COVER DIMENSIONS ARE MINIMUM.
5. CONCRETE SHALL BE IN ACCORDANCE WITH CNP SPECIFICATION 007-221-01, LATEST REVISION.
6. PLACE REINFORCING BARS IN 4 CORNERS OF THE CONCRETE WHERE SPACERS ARE USED.
7. ON COLD JOINT CONCRETE POUR USE #5 REBAR (3'-0" IN LENGTH, EXPOSED 1'-6").
8. LENGTH OF REBAR FOR SPACER ANCHOR WILL VARY PER DUCT BANK HEIGHT.
9. CONDUITS ENDS SHALL BE PLUGGED WITH A DUCT CAP OR OTHER TYPE OF CAPPING DEVICE.
10. A ONE FOOT (1') VERTICAL CLEARANCE MUST BE MAINTAINED BETWEEN CNP'S DUCTBANK AND ALL NON-CNP FACILITIES CROSSING THE DUCTBANK.
11. A FIVE FOOT (5') HORIZONTAL CLEARANCE MUST BE MAINTAINED BETWEEN CNP'S DUCTBANK AND ALL NON-CNP FACILITIES RUNNING PARALLEL TO THE DUCTBANK (JOINT TRENCHING NOT PERMITTED).
12. INSTALL JET LINE IN ALL CONDUITS AND A #14 AWG WIRE IN ONE CONDUIT.

THREE PHASE DUCTBANK
FEEDER

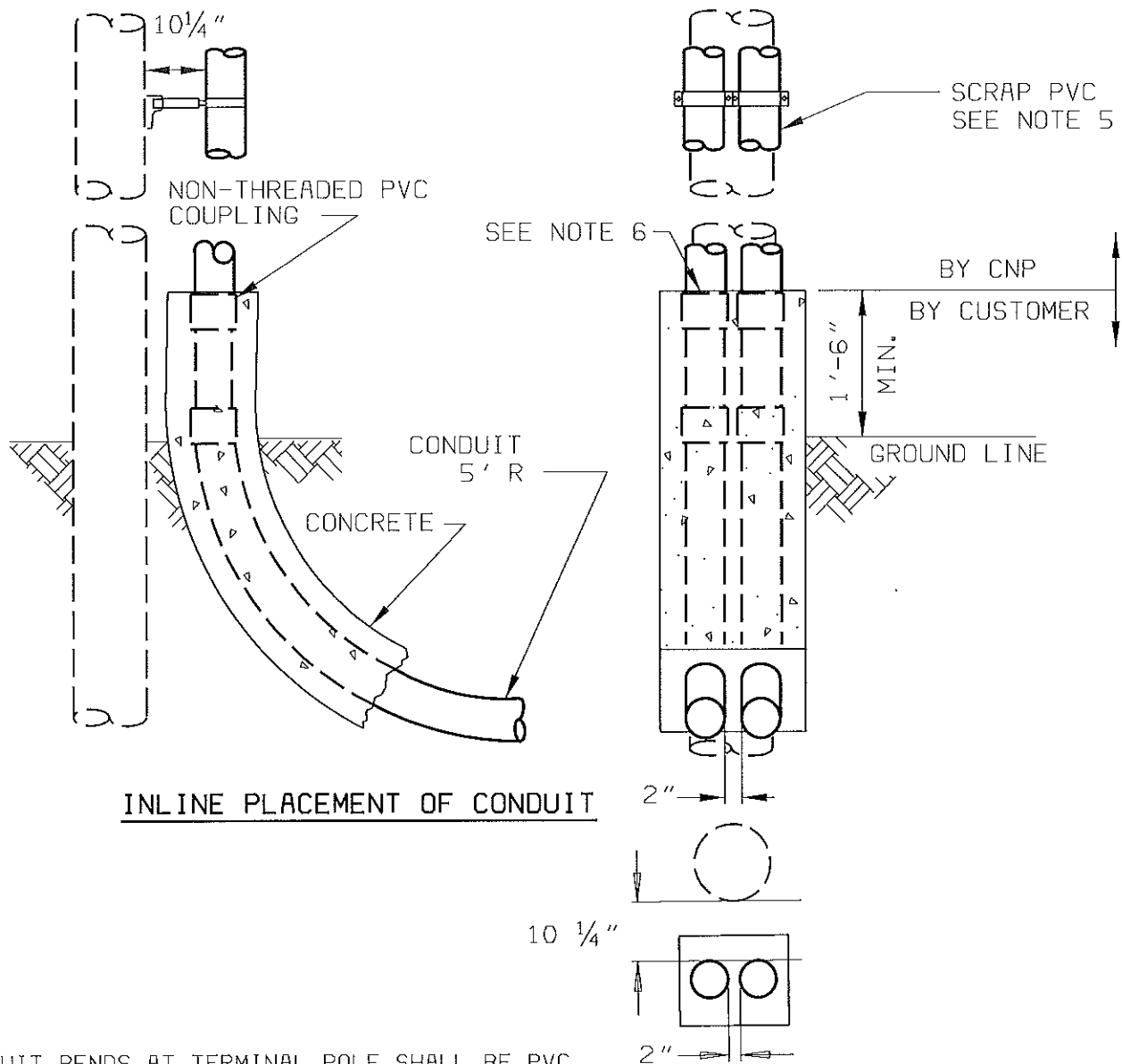

INLINE PLACEMENT OF CONDUIT

NOTES:

1. CONDUIT BENDS AT TERMINAL POLE SHALL BE PVC.
2. BRACE THE POLE SECURELY BEFORE TRENCHING.
3. INSTALL CONDUIT BENDS TO BASE OF POLE. ADD PORTIONS OF STRAIGHT CONDUIT AS NECESSARY TO OBTAIN THE PROPER HEIGHT ABOVE FINAL GRADE.
4. ATTACH COUPLING TO END OF CONDUIT.
5. INSERT, **BUT DO NOT GLUE**, A SHORT PIECE OF SCRAP PVC BUT DO NOT GLUE CONDUIT INTO THE TOP COUPLING. TIE CONDUIT TO BRACKET.
6. FORM AREA AROUND PEDESTAL TO THE TOP OF THE COUPLING. FORM PEDESTAL SO THAT NO CONCRETE WILL CONTACT POLE.
7. AFTER INSPECTION BY CNP, POUR CONCRETE TO TOP OF COUPLINGS.
8. ALL CONDUITS SHALL HAVE A MINIMUM 4" CONCRETE COVER.

TERMINAL POLE CONDUIT
PLACEMENT 12KV & 35 KV

98 BASED ON DISTRIBUTION STANDARD 65-500

031986/100207

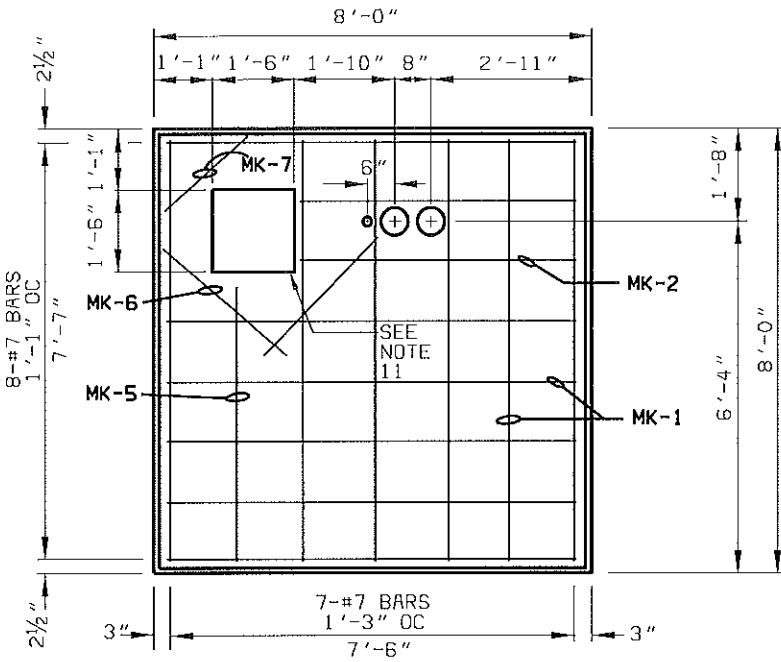

PLAN

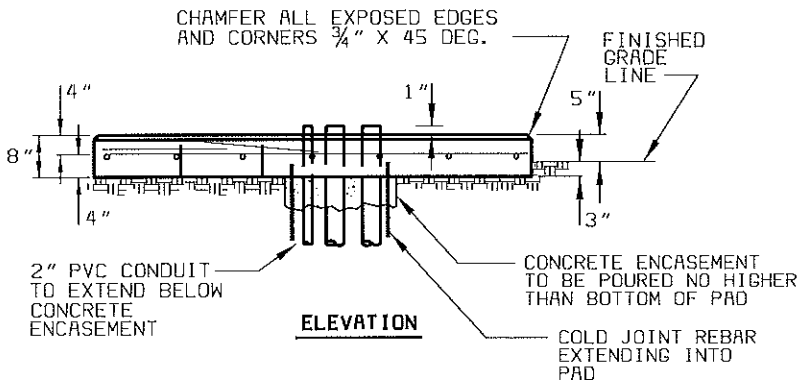

ELEVATION

NOTES:

1. CONCRETE SHALL BE IN ACCORDANCE WITH CNP SPECIFICATION 007-221-01, LATEST REVISION (MINIMUM COMPRESSION IN 28 DAYS, 3000 PSI).
2. REINFORCING STEEL SHALL BE INTERMEDIATE GRADE DEFORMED BARS IN ACCORDANCE WITH A.S.T.M. SPECIFICATION A-615, GRADE 60, OR BETTER.
3. ALL SPLICES IN REINFORCING SHALL LAP A LENGTH EQUAL TO 24 BAR DIAMETERS.
4. ALL DIMENSIONS ON REINFORCING ARE TO THE CENTER OF BARS.
5. CONCRETE SHALL BE THOROUGHLY WORKED AROUND REINFORCING, ANY EMBEDDED FIXTURES AND INTO ALL CORNERS OF FORMS.
6. IF REQUIRED, GROUT SHALL BE A MIXTURE OF 1 PART CEMENT TO 2 PARTS SAND WITH ENOUGH WATER TO PRODUCE A WORKABLE MIXTURE.
7. CONCRETE IS TO BE POURED ONLY WHEN THE ATMOSPHERIC TEMPERATURE IS A MINIMUM 40° F. AND RISING.
8. STRIP BACK ALL VEGETATION AND APPROXIMATELY 3" OF TOP SOIL. REMOVE ALL LOOSE CLODS AND STONES. BACKFILL AND THOROUGHLY COMPACT ALL CONDUIT TRENCHES AND HOLES BEFORE CONCRETE IS PLACED.
9. REINFORCING SHALL HAVE A MINIMUM OF 2½" CONCRETE COVER.
10. SLOPE PAD 1" FRONT TO BACK.
11. THE SQUARE OPENING IS FOR THE CUSTOMER'S SECONDARY CONDUITS.
12. CNP WILL NOT ALLOW OTHER FACILITIES TO PASS BENEATH ITS EQUIPMENT PADS. A ONE FOOT MINIMUM HORIZONTAL CLEARANCE SHALL BE MAINTAINED BETWEEN CNP PADS AND ALL OTHER FACILITIES.
13. THE SECONDARY OPENING IS TO BACKFILLED WITH SAND TO WITHIN 4" OF THE TOP OF THE PAD.

REINFORCING SCHEDULE PER FOUNDATION				
MARK	QTY.	SIZE	LENGTH	REMARKS
MK-1	12	#7	7'-7"	STRAIGHT
MK-2	2	#7	5'-0"	STRAIGHT
MK-3	0	#7	2'-4"	STRAIGHT
MK-4	0	#7	5'-0"	STRAIGHT
MK-5	1	#7	4'-6"	STRAIGHT
MK-6	2	#7	3'-0"	STRAIGHT
MK-7	1	#7	2'-0"	STRAIGHT

MATERIAL ESTIMATE PER FOUNDATION	
DESCRIPTION	QTY.
REINFORCING STEEL #7	232 LBS
CONCRETE (5 SACK)	1¾ CU. YDS.
2" PVC CONDUIT	5 FT
TYPE EB OR BETTER PVC CONDUIT, 90 DEG, 60" R	2

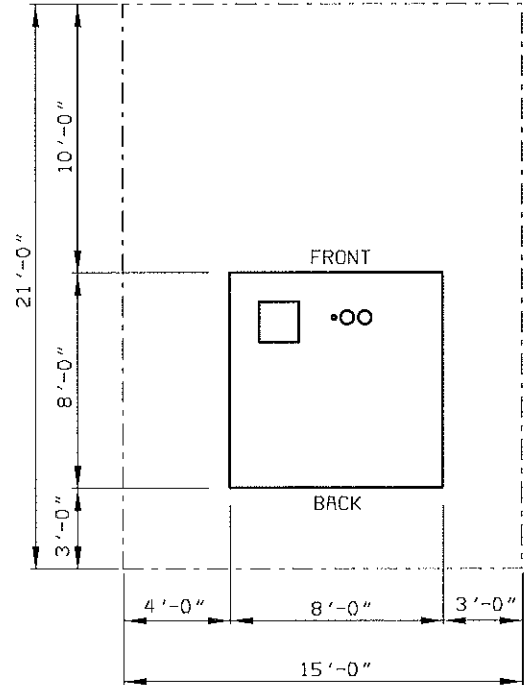

MINIMUM EASEMENT REQUIREMENTS

**EQUIPMENT WEIGHT
20,000 LBS
MAXIMUM**

**150-1000 KVA, 3 PHASE
PMT FOUNDATION, 12KV & 35 KV
(SPECIAL APPLICATION)**

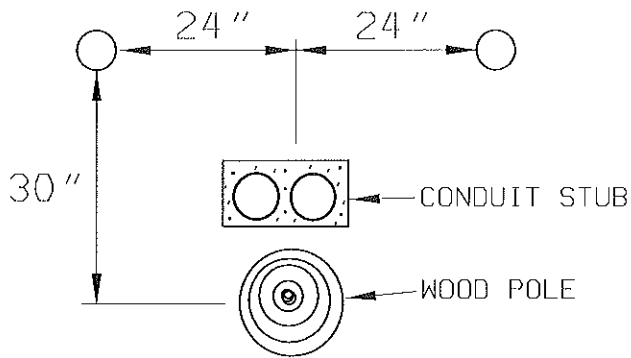

TERMINAL POLE PROTECTIVE BARRIER PLACEMENT

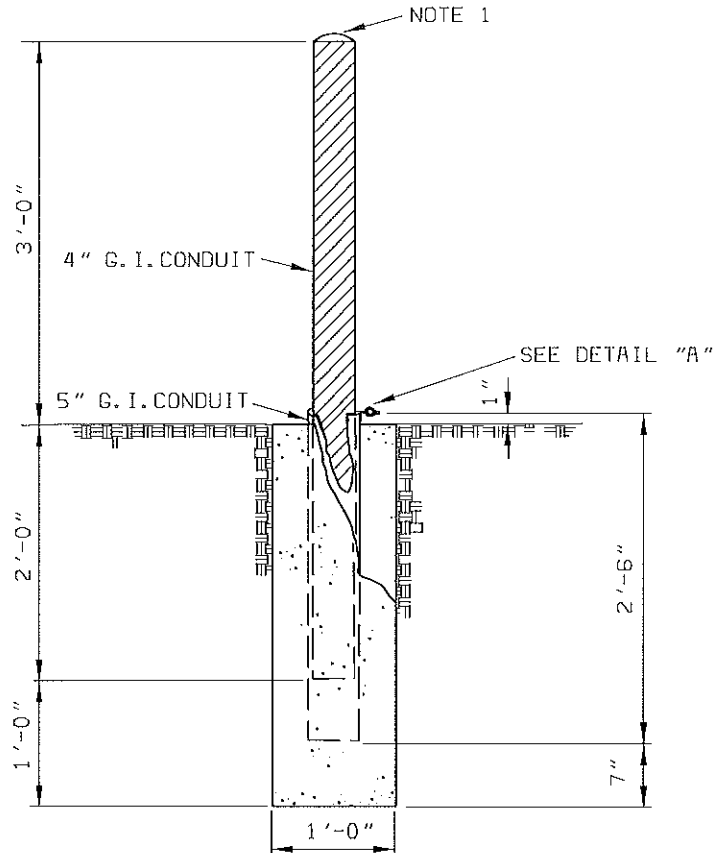

**PROTECTIVE BARRIER
(REMOVABLE)**

INSTALL ON APPROXIMATELY 4' CENTERS AS SPECIFIED ON SKETCH

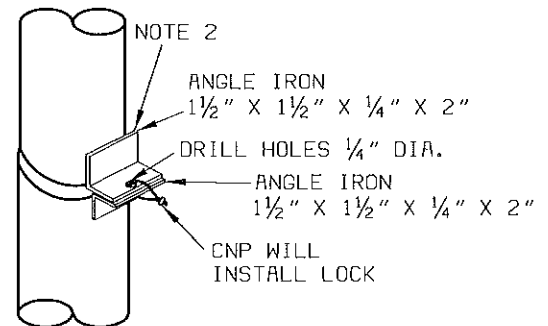

DETAIL "A"

NOTES:

1. 4" G. I. CONDUIT TO BE FILLED WITH CONCRETE.
2. ANGLE TO BE WELDED TO G. I. CONDUIT. ALL EXPOSED METAL TO BE PAINTED WITH GALVANOX PAINT.
3. SEAL GAP BETWEEN CONDUITS WITH DUCT SEAL FOR WATER TIGHT FIT.
4. USE 5" PLUG TO PREVENT CONCRETE FROM COMING UP 5" G. I. CONDUIT.

**PROTECTIVE BARRIER
(REMOVABLE)**

**CONSIDER APPROVAL OF MATERIALS TESTING
FOR CULVER ELEMENTARY SCHOOL**

RECOMMENDATION:

That the Board of Trustees approve Terracon, Inc. for materials testing for Culver Elementary School in the total amount of \$84,890 and authorize the Board President to execute the agreement.

IMPACT/RATIONALE:

Materials testing is a professional service that the District must contract directly. These funds were allocated within the 2014 Bond Budget.

PROGRAM DESCRIPTION:

Materials testing services will generate reports and verify that materials are installed correctly as per the specifications. These reports are crucial in verifying the quality of the construction of Culver Elementary School.

Submitted By: Kevin McKeever, Administrator for Operations
Steve Hoyt, Vanir/Rice & Gardner Consultants, Inc., A Joint Venture

Recommended for approval:



Dr. Thomas Randle
Superintendent



December 7, 2017

Lamar Consolidated Independent School District
Attn: Mr. J. Kevin McKeever
Administrator of Operations
3911 Avenue I
Rosenberg, Texas 77471

Subject: Proposal for Construction Materials Testing Services
LCISD Thomas R. Culver, III Elementary School
Briarwood Crossing Dr. and Coopers Hill Trail, Pleak, Texas
Terracon Proposal P92171578

Dear Mr. McKeever:

Terracon Consultants, Inc. (Terracon) is pleased to submit this proposal to provide construction materials engineering and testing services for the above referenced project. In this proposal we present our understanding of the scope of the project, our proposed services, and our budget estimate.

Terracon provided geotechnical services for this project. Our presence on this project and commitment to responsive quality services will make Terracon a valuable asset to the project.

A) PROJECT INFORMATION

The site is located at Briarwood Crossing Dr. and Coopers Hill Trail in Pleak, Texas. The project involves the construction of an elementary school with an approximate footprint of 95,000 sf. The building foundation will consist of a structural slab with drilled and underreamed piers. The superstructure will consist of a structural steel single-story building with mezzanine and masonry walls. In addition, civil work includes water, sanitary, and storm sewer utilities with site paving (6, 7, and 8 inch thick) supported by 6 inches of stabilized subgrade.

Terracon was provided with the following construction documents for preparation of this proposal:

- Terracon Consultants Geotechnical Report 92175312 dated October 19, 2017
- 95% Drawings prepared by VLK Architects, Inc.

If selected for this project, Terracon requests that we be placed on the distribution of all plan revisions.

B) SCOPE OF SERVICES

Terracon prepared the following scope of services based on our review and understanding of the documents listed above:

Earthwork:

1. Sample building pad subgrade, natural site materials, cement stabilized sand, treated pavement subgrade, utility backfill, and base. Prepare and test the samples for Atterberg Limits (ASTM D4318), moisture-density relationship (ASTM D698, ASTM D558, and ASTM D1557).
2. Sample cement-sand backfill for utility trenches, mold specimens, and perform compressive strength tests in the laboratory (ASTM D1633).
3. Evaluate the subgrade soil for proposed chemically treated pavement subgrade.
4. Observe the chemical treatment process for the pavement subgrade.
5. Perform field gradation tests of treated subgrade.
6. Measure the depth of treated subgrade using phenolphthalein.
7. Observe proofrolling operations of the building pad subgrade and pavement subgrades; and perform density tests of the building pad subgrade, cement stabilized sand, treated pavement subgrade, utility backfill, and base using the nuclear method (ASTM D6938) to determine the moisture content and percent compaction of the soil materials.

Foundations:

1. Observe the installation of the drilled pier foundations. For each pier observed, information regarding shaft depth, auger diameter, and chained belling tool diameter will be documented. The chained belling tool diameter will be measured when extended above ground for each bell size.
2. Obtain pocket penetrometer readings on soil cuttings removed during excavation at or near the bearing stratum and document the approximate shear strength of the soil.

3. Perform compressive tests of concrete test cylinders cast in the field (ASTM C1231 or C617, C39).

Cast-in-Place Concrete:

1. Sample and test the fresh concrete for each mix. Perform tests for slump, air content, and concrete temperature only; and cast test specimens (ASTM C172, C31, C143, C173 or C231, and C1064). Terracon understands that the contractor will be responsible for maintaining the initial curing temperature of the concrete test specimens. Terracon will record the initial curing temperatures only when conditioned curing boxes are provided by the contractor.
2. Concrete will be sampled at a frequency of 1 set of test cylinders every 50 cubic yards of structural concrete and every 125 cubic yards of paving, sidewalks, and area paving. Terracon requests that a copy of the approved mix design(s) be provided to us prior to placement of the concrete.
3. Perform compressive strength tests of concrete test cylinders cast in the field (ASTM C1231, C39). Four 6" x 12" concrete cylinders per set will be prepared for strength testing (1 for 7-day, 2 for 28-days and 1 for 56 days). If 4" x 8" cylinders are used, a set of 5 will be cast (1 for 7 days, 3 for 28 days, and 1 for 56 days)
4. Observe reinforcing steel prior to concrete placement. We will observe the rebar size, spacing and configuration. **Terracon recommends we be scheduled a minimum of 24 hours prior to each concrete placement.**
5. Within 48 hours of concrete placement, travel to project site to collect and transport hardened concrete test cylinders to Terracon's Houston laboratory for processing, curing and testing.

Spray-Applied Fireproofing Materials:

Measure fireproofing thickness of in place fireproofing material; sample fireproofing material to determine in-place density by displacement method; and measure adhesion cohesion of the fireproofing material. Terracon will test the fireproofing in accordance with the frequency and testing standards referenced in the IBC code noted in the project documents (ASTM E605 and ASTM E736).

Masonry:

1. Observe and document the condition of storage areas for masonry materials.
2. Observe and document the mixing proportions of grout used during construction.
3. Observe the reinforcing steel in CMU walls and bond beams.
4. Sample the fresh grout during construction and cast grout prisms (ASTM C1019) for compressive strength tests.
5. Observe fabrication of CMU prisms, transport CMU prisms to our laboratory after initial curing, and test for compressive strength.

Structural Steel Welded and Bolted Connections:

1. Terracon recommends that the general contractor schedule a pre-erection meeting to discuss the erection sequence, review welding and bolting requirements and to review welder certification records.
2. Provide a Certified Welding Inspector (CWI) in the field to visually check accessible field bolted/welded connections in accordance with applicable AISC and AWS specifications.
3. Perform visual inspections of metal decking for placement including overlap, fastener spacing, shear studs for number, pattern, and bond, supports at openings and penetrations, and puddle welds pattern, size and quality.

Project Management/ Administration:

A project manager will be assigned to the project to review the daily activity and assist in scheduling the work. Field and laboratory tests will be reviewed prior to submittal. The project manager will be responsible for maintaining the project budget and will oversee the preparation of the final test reports.

Terracon recommends that the general contractor schedule pre-construction meetings prior to each phase of our proposed testing and observations to discuss the erection sequence, review welding and bolting requirements and to review welder certification records.

Special Inspections Letter:

Upon completion of our services, a special inspection letter will be prepared, if requested. The letter will list services we performed and if the results and/ or observations were in compliance with the project documents. A copy of our test reports will be available with the special inspection letter if requested.

Scheduling Retests:

It is the responsibility of your representative to schedule retests in a like manner to scheduling our original services. Terracon shall not be held responsible for retests not performed as a result of a failure to schedule our services or any subsequent damage caused as a result of a lack of retesting.

Additional Services:

If you would like us to perform additional work, please contact us and we will issue a short Supplement to Agreement form, or Supplemental Proposal, that outlines the additional work to be performed and associated fees. To authorize us to begin work, you simply return a signed copy of the Supplemental agreement.

Mechanically Stabilized Earth (MSE) Walls:

This proposal excludes materials testing and observations related to mechanically stabilized earth (MSE) walls. Should the owner or client require Terracon to provide services on any portion of the MSE wall, Terracon should be requested to provide a separate proposal prior to start of construction of the MSE walls. Terracon requires an internal cursory review of the MSE wall design. This cursory review is only for internal Terracon purposes and is intended to establish the appropriate scope of construction materials testing services for the project if it is decided we will accept the assignment. This review should not be construed as accepting any design responsibility or providing any review capacity for the contractor or owner.

C) REPORTING

Results of field tests will be submitted verbally to available personnel at the site. Written reports of field tests and observations will be distributed within five business days. Test reports will be distributed via email. You will need to provide Terracon with a distribution list prior to the beginning of the project. The list will need to include the company name, address, contact person name, phone number, and e-mail address for each person. Our reported test locations will typically be

estimated by pacing distances and approximating angles and elevations from local control data (staking and layout lines) provided by others on site. The accuracy of our locations will be dependent on the accuracy, availability and frequency of the control points provided by the client and/ or contractor.

PROJECT STAFFING AND ADMINISTRATION

Field testing services will be provided on an "as requested" basis when scheduled by your representative. A notice of 24 hours (48 hours is required for structural steel services) is required to properly schedule our services. To schedule our services please contact our dispatcher at (713) 690-2258. The dispatch office hours are from 7:00 a.m. to 5:00 p.m. Messages left after business hours will be checked the following business day. Terracon shall not be held responsible for tests not performed as a result of a failure to schedule our services or any subsequent damage caused as a result of a lack of testing.

Terracon recommends that a copy of this proposal be provided to the general contractor so they understand our scope of services and schedule us accordingly. Please note that the number of tests and trips described in the Scope of Services does not constitute a minimum or maximum number of tests or trips that may be required for this project.

D) COMPENSATION

Based on the project information available for our review, we propose an estimate cost of **\$84,890**. Services provided will be based on the unit rates included in the attached Cost Estimate. Please note that this is only a budget estimate and not a not-to-exceed price. Many factors beyond our control, such as weather and the contractor's schedule, will dictate the final fee for our services. Quantities for re-tests, cancellations and stand-by time are not included in our fee.

For services provided on an "as requested" basis, overtime is defined as all hours in excess of eight hours per day, outside of the normal hours of 7:00 a.m. to 6:00 p.m. Monday through Friday, and all hours worked on weekends and holidays. Overtime rates will be 1.5 times the hourly rate quoted. A four hour minimum charge is applicable to all trips made to provide our testing, observation and consulting services. The minimum charge is not applicable for trips to the project site for sample pickup only. All labor, equipment and transportation charges are billed on a portal to portal basis from our office. You will be invoiced on a monthly basis for services actually performed and/or as authorized by you or your designated representative. Terracon's total invoice fee is due within thirty days following final receipt of invoice.

E) SITE ACCESS AND SAFETY

Client shall secure all necessary site related approvals, permits, licenses, and consents necessary to commence and complete the services and will execute any necessary site access agreement. Terracon will be responsible for supervision and site safety measures for its own employees, but shall not be responsible for the supervision or health and safety precautions for any third parties, including Client's contractors, subcontractors, or other parties present at the site.

F) TESTING AND OBSERVATION

Client understands that testing and observation are discrete sampling procedures, and that such procedures indicate conditions only at the depths, locations, and times the procedures were performed. Terracon will provide test results and opinions based on tests and field observations only for the work tested. Client understands that testing and observation are not continuous or exhaustive, and are conducted to reduce – not eliminate - project risk. Client agrees to the level or amount of testing performed and the associated risk. Client is responsible (even if delegated to contractor) for notifying and scheduling Terracon so Terracon can perform these services. Terracon shall not be responsible for the quality and completeness of Client's contractor's work or their adherence to the project documents, and Terracon's performance of testing and observation services shall not relieve contractor in any way from its responsibility for defects discovered in its work, or create a warranty or guarantee. Terracon will not supervise or direct the work performed by contractor or its subcontractors and is not responsible for their means and methods.

G) AUTHORIZATION

This proposal may be accepted by executing the attached Agreement For Services and returning an executed copy along with this proposal to Terracon. This proposal for services and accompanying limitations shall constitute the exclusive terms, conditions and services to be performed for this project. This proposal is valid only if authorized within sixty days from the listed proposal date. **Terracon cannot begin field and laboratory services without a signed Agreement for Services.**

Proposal for Construction Materials Testing Services

Lamar Consolidated ISD Culver Elementary School
Briarwood Crossing Dr. and Coopers Hill Trail, Pleak, TX
December 7, 2017 • Terracon Proposal No. P92171578



We appreciate this opportunity of working with you and we look forward to working with you in the future.

Sincerely,
Terracon Consultants, Inc.
(TBPE Firm Registration No. F-3272)

A handwritten signature in blue ink, appearing to read 'Mark D. Wells'.

Mark D. Wells, P.E., PMP
Senior Engineer

A handwritten signature in blue ink, appearing to read 'Chad C. Gordon'.

Chad C. Gordon, P.E.
Materials Services Manager

Attachments:

- (1) Cost Estimate
- (2) Agreement For Services



COST ESTIMATE

LCISD Culver Elementary School
 Briarwood Crossing Dr. and Coopers Hill Trail, Pleak, Texas
 Terracon Proposal P92171578

Service (As described in proposal)	Quantity	Unit	Unit Rate	Estimate
EARTHWORK				
Field Representative, Regular Hours	200	hours	\$ 46.00	\$ 9,200.00
Field Representative, Overtime Hours	40	hours	\$ 69.00	\$ 2,760.00
Nuclear Density Gauge	40	trip	\$ 60.00	\$ 2,400.00
Lime Determination	2	each	\$ 300.00	\$ 600.00
Moisture Density Relationship	8	each	\$ 165.00	\$ 1,320.00
Atterberg Limits	8	each	\$ 65.00	\$ 520.00
Cement Stabilized Sand	12	each	\$ 60.00	\$ 720.00
Vehicle Charge	40	trip	\$ 60.00	\$ 2,400.00
Subtotal, Earthwork				\$ 19,920.00
FOUNDATIONS				
Senior Field Representative, Regular Hours	160	hours	\$ 46.00	\$ 7,360.00
Senior Field Representative, Overtime Hours	40	hours	\$ 69.00	\$ 2,760.00
Concrete Compressive Strength	80	each	\$ 16.00	\$ 1,280.00
Vehicle Charge	20	trip	\$ 60.00	\$ 1,200.00
Sample Pickup (inclusive of labor and vehicle charge)	4	trip	\$ 150.00	\$ 600.00
Subtotal, Foundations				\$ 13,200.00
CAST-IN-PLACE CONCRETE				
Field Representative, Regular Hours	220	hours	\$ 46.00	\$ 10,120.00
Field Representative, Overtime Hours	60	hours	\$ 69.00	\$ 4,140.00
Concrete Compressive Strength	420	each	\$ 16.00	\$ 6,720.00
Vehicle Charge	40	trip	\$ 60.00	\$ 2,400.00
Sample Pickup (inclusive of labor and vehicle charge)	10	trip	\$ 150.00	\$ 1,500.00
Subtotal, Cast-in-Place Concrete				\$ 24,880.00
STRUCTURAL STEEL				
Certified Welding Inspector, Regular Hours	40	hours	\$ 90.00	\$ 3,600.00
Field Representative, Regular Hours	8	hours	\$ 46.00	\$ 368.00
Grout Compressive Strength (sets of 6)	24	each	\$ 35.00	\$ 840.00
Vehicle Charge	10	trip	\$ 60.00	\$ 600.00
Ultrasonic Equipment	2	trip	\$ 100.00	\$ 200.00
Sample Pickup (inclusive of labor and vehicle charge)	1	trip	\$ 150.00	\$ 150.00
Subtotal, Structural Steel				\$ 5,758.00
FIREPROOFING				
Field Representative, Regular Hours	64	hours	\$ 46.00	\$ 2,944.00
Vehicle Charge	15	trip	\$ 60.00	\$ 900.00
Adhesion/Cohesion	30	each	\$ 25.00	\$ 750.00
Density	30	each	\$ 30.00	\$ 900.00
Subtotal, Fireproofing				\$ 5,494.00



COST ESTIMATE

LCISD Culver Elementary School

Briarwood Crossing Dr. and Coopers Hill Trail, Pleak, Texas

Terracon Proposal P92171578

MASONRY				
Field Representative, Regular hours	48	hours	\$ 46.00	\$ 2,208.00
Grout Compressive Strength (sets of 4)	48	each	\$ 35.00	\$ 1,680.00
Vehicle Charge	12	trip	\$ 60.00	\$ 720.00
Sample Pickup (inclusive of labor and vehicle charge)	12	trip	\$ 150.00	\$ 1,800.00
Subtotal, Masonry				\$ 6,408.00
PROJECT MANAGEMENT				
Project Manager & Administration	70	hours	\$ 125.00	\$ 8,750.00
Vehicle Charge	8	trip	\$ 60.00	\$ 480.00
Subtotal, Project Management & Administration				\$ 9,230.00
ESTIMATED COST				\$ 84,890.00

AGREEMENT FOR SERVICES

This **AGREEMENT** is between Lamar Consolidated ISD ("Client") and Terracon Consultants, Inc. ("Consultant") for Services to be provided by Consultant for Client on the LCISD Culver Elementary School project ("Project"), as described in the Project Information section of Consultant's Proposal dated 12/07/2017 ("Proposal") unless the Project is otherwise described in Exhibit A to this Agreement (which section or Exhibit is incorporated into this Agreement).

1. **Scope of Services.** The scope of Consultant's services is described in the Scope of Services section of the Proposal ("Services"), unless Services are otherwise described in Exhibit B to this Agreement (which section or exhibit is incorporated into this Agreement). Portions of the Services may be subcontracted. When Consultant subcontracts to other individuals or companies, then consultant will collect from Client on the Subcontractors' behalf. Consultant's Services do not include the investigation or detection of, nor do recommendations in Consultant's reports address the presence or prevention of biological pollutants (e.g., mold, fungi, bacteria, viruses, or their byproducts) or occupant safety issues, such as vulnerability to natural disasters, terrorism, or violence. If Services include purchase of software, Client will execute a separate software license agreement. Consultant's findings, opinions, and recommendations are based solely upon data and information obtained by and furnished to Consultant at the time of the Services.
2. **Acceptance/ Termination.** Client agrees that execution of this Agreement is a material element of the consideration Consultant requires to execute the Services, and if Services are initiated by Consultant prior to execution of this Agreement as an accommodation for Client at Client's request, both parties shall consider that commencement of Services constitutes formal acceptance of all terms and conditions of this Agreement. Additional terms and conditions may be added or changed only by written amendment to this Agreement signed by both parties. In the event Client uses a purchase order or other form to administer this Agreement, the use of such form shall be for convenience purposes only and any additional or conflicting terms it contains are stricken. This Agreement shall not be assigned by either party without prior written consent of the other party. Either party may terminate this Agreement or the Services upon written notice to the other. In such case, Consultant shall be paid costs incurred and fees earned to the date of termination plus reasonable costs of closing the Project.
3. **Change Orders.** Client may request changes to the scope of Services by altering or adding to the Services to be performed. If Client so requests, Consultant will return to Client a statement (or supplemental proposal) of the change setting forth an adjustment to the Services and fees for the requested changes. Following Client's review, Client shall provide written acceptance. If Client does not follow these procedures, but instead directs, authorizes, or permits Consultant to perform changed or additional work, the Services are changed accordingly and Consultant will be paid for this work according to the fees stated or its current fee schedule. If project conditions change materially from those observed at the site or described to Consultant at the time of proposal, Consultant is entitled to a change order equitably adjusting its Services and fee.
4. **Compensation and Terms of Payment.** Client shall pay compensation for the Services performed at the fees stated in the Compensation section of the Proposal unless fees are otherwise stated in Exhibit C to this Agreement (which section or Exhibit is incorporated into this Agreement). If not stated in either, fees will be according to Consultant's current fee schedule. Fee schedules are valid for the calendar year in which they are issued. Fees do not include sales tax. Client will pay applicable sales tax as required by law. Consultant may invoice Client at least monthly and payment is due upon receipt of invoice. Client shall notify Consultant in writing, at the address below, within 15 days of the date of the invoice if Client objects to any portion of the charges on the invoice, and shall promptly pay the undisputed portion. Client shall pay a finance fee of 1.5% per month, but not exceeding the maximum rate allowed by law, for all unpaid amounts 30 days or older. Client agrees to pay all collection-related costs that Consultant incurs, including attorney fees. Consultant may suspend Services for lack of timely payment. It is the responsibility of Client to determine whether federal, state, or local prevailing wage requirements apply and to notify Consultant if prevailing wages apply. If it is later determined that prevailing wages apply, and Consultant was not previously notified by Client, Client agrees to pay the prevailing wage from that point forward, as well as a retroactive payment adjustment to bring previously paid amounts in line with prevailing wages. Client also agrees to defend, indemnify, and hold harmless Consultant from any alleged violations made by any governmental agency regulating prevailing wage activity for failing to pay prevailing wages, including the payment of any fines or penalties.
5. **Third Party Reliance.** This Agreement and the Services provided are for Consultant and Client's sole benefit and exclusive use with no third party beneficiaries intended. Reliance upon the Services and any work product is limited to Client, and is not intended for third parties other than those who have executed Consultant's reliance agreement, subject to the prior approval of Consultant and Client.
6. **LIMITATION OF LIABILITY.** CLIENT AND CONSULTANT HAVE EVALUATED THE RISKS AND REWARDS ASSOCIATED WITH THIS PROJECT, INCLUDING CONSULTANT'S FEE RELATIVE TO THE RISKS ASSUMED, AND AGREE TO ALLOCATE CERTAIN OF THE ASSOCIATED RISKS. TO THE FULLEST EXTENT PERMITTED BY LAW, THE TOTAL AGGREGATE LIABILITY OF CONSULTANT (AND ITS RELATED CORPORATIONS AND EMPLOYEES) TO CLIENT AND THIRD PARTIES GRANTED RELIANCE IS LIMITED TO THE GREATER OF \$50,000 OR CONSULTANT'S FEE, FOR ANY AND ALL INJURIES, DAMAGES, CLAIMS, LOSSES, OR EXPENSES (INCLUDING ATTORNEY AND EXPERT FEES) ARISING OUT OF CONSULTANT'S SERVICES OR THIS AGREEMENT. PRIOR TO ACCEPTANCE OF THIS AGREEMENT AND UPON WRITTEN REQUEST FROM CLIENT, CONSULTANT MAY NEGOTIATE A HIGHER LIMITATION FOR ADDITIONAL CONSIDERATION IN THE FORM OF A SURCHARGE TO BE ADDED TO THE AMOUNT STATED IN THE COMPENSATION SECTION OF THE PROPOSAL. THIS LIMITATION SHALL APPLY REGARDLESS OF AVAILABLE PROFESSIONAL LIABILITY INSURANCE COVERAGE, CAUSE(S), OR THE THEORY OF LIABILITY, INCLUDING NEGLIGENCE, INDEMNITY, OR OTHER RECOVERY. THIS LIMITATION SHALL NOT APPLY TO THE EXTENT THE DAMAGE IS PAID UNDER CONSULTANT'S COMMERCIAL GENERAL LIABILITY POLICY.
7. **Indemnity/Statute of Limitations.** Consultant and Client shall indemnify and hold harmless the other and their respective employees from and against legal liability for claims, losses, damages, and expenses to the extent such claims, losses, damages, or expenses are legally determined to be caused by their negligent acts, errors, or omissions. In the event such claims, losses, damages, or expenses are legally determined to be caused by the joint or concurrent negligence of Consultant and Client, they shall be borne by each party in proportion to its own negligence under comparative fault principles. Neither party shall have a duty to defend the other party, and no duty to defend is hereby created by this indemnity provision and such duty is explicitly waived under this Agreement. Causes of action arising out of Consultant's Services or this Agreement regardless of cause(s) or the theory of liability, including negligence, indemnity or other recovery shall be deemed to have accrued and the applicable statute of limitations shall commence to run not later than the date of Consultant's substantial completion of Services on the project.
8. **Warranty.** Consultant will perform the Services in a manner consistent with that level of care and skill ordinarily exercised by members of the profession currently practicing under similar conditions in the same locale. EXCEPT FOR THE STANDARD OF CARE PREVIOUSLY STATED, CONSULTANT MAKES NO WARRANTIES OR GUARANTEES, EXPRESS OR IMPLIED, RELATING TO CONSULTANT'S SERVICES AND CONSULTANT DISCLAIMS ANY IMPLIED WARRANTIES OR WARRANTIES IMPOSED BY LAW, INCLUDING WARRANTIES OF MERCHANTABILITY AND FITNESS FOR A PARTICULAR PURPOSE.

- 9. Insurance.** Consultant represents that it now carries, and will continue to carry: (i) workers' compensation insurance in accordance with the laws of the states having jurisdiction over Consultant's employees who are engaged in the Services, and employer's liability insurance (\$1,000,000); (ii) commercial general liability insurance (\$1,000,000 occ / \$2,000,000 agg); (iii) automobile liability insurance (\$1,000,000 B.I. and P.D. combined single limit); and (iv) professional liability insurance (\$1,000,000 claim / agg). Certificates of insurance will be provided upon request. Client and Consultant shall waive subrogation against the other party on all general liability and property coverage.
- 10. CONSEQUENTIAL DAMAGES.** NEITHER PARTY SHALL BE LIABLE TO THE OTHER FOR LOSS OF PROFITS OR REVENUE; LOSS OF USE OR OPPORTUNITY; LOSS OF GOOD WILL; COST OF SUBSTITUTE FACILITIES, GOODS, OR SERVICES; COST OF CAPITAL; OR FOR ANY SPECIAL, CONSEQUENTIAL, INDIRECT, PUNITIVE, OR EXEMPLARY DAMAGES.
- 11. Dispute Resolution.** Client shall not be entitled to assert a Claim against Consultant based on any theory of professional negligence unless and until Client has obtained the written opinion from a registered, independent, and reputable engineer, architect, or geologist that Consultant has violated the standard of care applicable to Consultant's performance of the Services. Client shall provide this opinion to Consultant and the parties shall endeavor to resolve the dispute within 30 days, after which Client may pursue its remedies at law. This Agreement shall be governed by and construed according to Kansas law.
- 12. Subsurface Explorations.** Subsurface conditions throughout the site may vary from those depicted on logs of discrete borings, test pits, or other exploratory services. Client understands Consultant's layout of boring and test locations is approximate and that Consultant may deviate a reasonable distance from those locations. Consultant will take reasonable precautions to reduce damage to the site when performing Services; however, Client accepts that invasive services such as drilling or sampling may damage or alter the site. Site restoration is not provided unless specifically included in the Services.
- 13. Testing and Observations.** Client understands that testing and observation are discrete sampling procedures, and that such procedures indicate conditions only at the depths, locations, and times the procedures were performed. Consultant will provide test results and opinions based on tests and field observations only for the work tested. Client understands that testing and observation are not continuous or exhaustive, and are conducted to reduce - not eliminate - project risk. Client shall cause all tests and inspections of the site, materials, and Services performed by Consultant to be timely and properly scheduled in order for the Services to be performed in accordance with the plans, specifications, contract documents, and Consultant's recommendations. No claims for loss or damage or injury shall be brought against Consultant by Client or any third party unless all tests and inspections have been so performed and Consultant's recommendations have been followed. Unless otherwise stated in the Proposal, Client assumes sole responsibility for determining whether the quantity and the nature of Services ordered by Client is adequate and sufficient for Client's intended purpose. Client is responsible (even if delegated to contractor) for requesting services, and notifying and scheduling Consultant so Consultant can perform these Services. Consultant is not responsible for damages caused by Services not performed due to a failure to request or schedule Consultant's Services. Consultant shall not be responsible for the quality and completeness of Client's contractor's work or their adherence to the project documents, and Consultant's performance of testing and observation services shall not relieve Client's contractor in any way from its responsibility for defects discovered in its work, or create a warranty or guarantee. Consultant will not supervise or direct the work performed by Client's contractor or its subcontractors and is not responsible for their means and methods. The extension of unit prices with quantities to establish a total estimated cost does not guarantee a maximum cost to complete the Services. The quantities, when given, are estimates based on contract documents and schedules made available at the time of the Proposal. Since schedule, performance, production, and charges are directed and/or controlled by others, any quantity extensions must be considered as estimated and not a guarantee of maximum cost.
- 14. Sample Disposition, Affected Materials, and Indemnity.** Samples are consumed in testing or disposed of upon completion of the testing procedures (unless stated otherwise in the Services). Client shall furnish or cause to be furnished to Consultant all documents and information known or available to Client that relate to the identity, location, quantity, nature, or characteristic of any hazardous waste, toxic, radioactive, or contaminated materials ("Affected Materials") at or near the site, and shall immediately transmit new, updated, or revised information as it becomes available. Client agrees that Consultant is not responsible for the disposition of Affected Materials unless specifically provided in the Services, and that Client is responsible for directing such disposition. In no event shall Consultant be required to sign a hazardous waste manifest or take title to any Affected Materials. Client shall have the obligation to make all spill or release notifications to appropriate governmental agencies. The Client agrees that Consultant neither created nor contributed to the creation or existence of any Affected Materials conditions at the site and Consultant shall not be responsible for any claims, losses, or damages allegedly arising out of Consultant's performance of Services hereunder, or for any claims against Consultant as a generator, disposer, or arranger of Affected Materials under federal, state, or local law or ordinance.
- 15. Ownership of Documents.** Work product, such as reports, logs, data, notes, or calculations, prepared by Consultant shall remain Consultant's property. Proprietary concepts, systems, and ideas developed during performance of the Services shall remain the sole property of Consultant. Files shall be maintained in general accordance with Consultant's document retention policies and practices.
- 16. Utilities.** Client shall provide the location and/or arrange for the marking of private utilities and subterranean structures. Consultant shall take reasonable precautions to avoid damage or injury to subterranean structures or utilities. Consultant shall not be responsible for damage to subterranean structures or utilities that are not called to Consultant's attention, are not correctly marked, including by a utility locate service, or are incorrectly shown on the plans furnished to Consultant.
- 17. Site Access and Safety.** Client shall secure all necessary site related approvals, permits, licenses, and consents necessary to commence and complete the Services and will execute any necessary site access agreement. Consultant will be responsible for supervision and site safety measures for its own employees, but shall not be responsible for the supervision or health and safety precautions for any other parties, including Client, Client's contractors, subcontractors, or other parties present at the site.

Consultant: Terracon Consultants, Inc.
By: *Mark D Wells* Date: 12/7/2017
Name/Title: Mark D Wells / Senior Project Materials Engineer
Address: 11555 Clay Rd Ste 100
Houston, TX 77043-1239
Phone: (713) 690-8989 Fax: (713) 690-8787
Email: Mark.Wells@terracon.com

Client: Lamar Consolidated ISD
By: _____ Date: _____
Name/Title: James Steenberg / Board President
Address: 3911 Avenue I
Rosenberg, TX 77471
Phone: 832-223-0000 Fax: _____
Email: _____

**CONSIDER APPROVAL OF BASE COST INCREASE FOR
REFURBISHED MOVING VAN SEMI-TRAILERS**

RECOMMENDATION:

That the Board of Trustees approve the purchase of refurbished moving van trailers in an amount not to exceed \$85,000, along with the approval for budget amendment as necessary.

IMPACT/RATIONALE:

We expect to realize approximately \$10,000 in annual savings by minimizing the need to use rental trucks. Trailers will be pulled by truck tractor to transport equipment to events in which Lamar CISD participates, such as band and athletic events. Trailers will be purchased in a base model, with a price not to exceed \$85,000 per trailer.

This price includes:

- delivery of a road-ready, DOT certified, 53-foot trailer with 3 curb-side doors, 1 street-side barn door, and hinged back doors;
- installation of a 23-foot second deck approximately 45 inches above the main deck, safety rails, industry standard load bars and $\frac{3}{4}$ " plywood decking, high durability commercial carpet on the second floor;
- fixed interior stairs, retracting stairs at all trailer side entry points;
- installation of a full-width dual stage hydraulic ramp with associated mobile power unit;
- 12 feet of custom shelving on the upper deck for instrument storage;
- installation of 12-volt low-profile interior LED lights (8 upstairs and 5 downstairs);
- installation of 12-volt exterior flood lights (10 lights);
- Installation of a power center including a charging circuit, battery, and lights switches with voltmeter and USB charging ports;
- Installation of a roof-mounted solar panel to maintain battery charge without the need to plug the trailer into generator power or the tractor.

This price represents 4 trailers with a fully built-out interior. Funding will come from 2011 available bond funds. Installation of decal removal, painting, application of exterior wraps, etc. may be purchased separately to customize the base trailer according to each campus's needs.

Tractors will be purchased through the transportation budget, which will be offset by rental and other fees.

Submitted by: Kevin McKeever, Administrator for Operations
Mike Jones, Director of Transportation
Ram Estrada, Director of Fine Arts
Lamanda Nipps, Purchasing and Materials Manager
Jill Ludwig, CPA, RTSBA, Chief Financial Officer

Recommended for approval:

Thomas Randle

Dr. Thomas Randle
Superintendent

BACKGROUND

The high school marching bands need to transition to semi-trailers to replace the 48-foot gooseneck trailers – the bands have outgrown using the trailers. Our 48-foot trailers offer 2,700 square feet of storage space, and the 53-foot trailers with a second deck offer 4,240 square feet of storage space. One driver can drive the semi-trailer tractor, whereas we have used up to three drivers for the 48-foot trailer, District maintenance van and a rental truck.

There is also a benefit in the safety features the semi-trailers offer. Rental vans provide a lift gate that have potential for students and adult volunteers to accidentally walk off from a 4-foot drop. There is also a high risk of our equipment to fall off the narrow lift platform and be damaged. There are many hinges on a lift gate where careless hands could get pinched during operation. The 53-foot semi-trailers have a hydraulic ramp that rises approximately 30 inches off the ground at a safe incline, and they offer multiple points of entry. The 48-foot trailers only offer one surface for moving and storage, with limited points of entry. It currently takes approximately 45 minutes after each event to load trailers and trucks, keeping the entire band out later during events. With multiple entry points on the semi-trailer, students and parent volunteers can load more efficiently, allowing students to leave late-night events quicker.

Using rental trucks that are not customized to specific needs allows instruments to move during transport; this adds unneeded wear on the instruments and impacts the effective life-span for instruments and an increased need for repair. Many marching band events happen at night - the semi-trailers offer the advantage of copious amounts of light both inside the trailer as well as outside the trailer.

Transitioning to the 53-foot semi-trailer is now a best practice in many school districts around the country to safely and cost-effectively transport the large marching band inventory to and from competitive events and football games.

INFORMATION ITEM: BOARD POLICIES -- FIRST READING

The following local policies are attached for review:

- Localized Policy Manual Update 109

Local policies are customized to provide a procedure or guidelines to enforce the legal policies and district guidelines.

Resource Person: Dr. Thomas Randle, Superintendent

Localized Policy Manual Update 109

Lamar CISD

Remember: You can download a PDF of this update packet, annotated copies of the (LOCAL) policies, editable (LOCAL) text, and more on my.tasb.org under *Policy Service Resource Library: Local Manual Updates*.

Need help? Please call your policy consultant at 800-580-7529 or e-mail Policy.Service@TASB.org.

Contents

Overview	1
(LEGAL) vs. (LOCAL) Policies: Remember the Difference	3
How to Place Policy Changes on the Agenda for Board Action	3
How to Notify Policy Service of Board Action	4
How to Keep Minutes	4
How to Maintain Your Historical Record	4
How to Keep Your Administrative Regulations Current	5
Disclaimer and Copyright	5

Overview

Update 109 encompasses changes in law from the 85th Legislative Session that have an immediate effect on the governance and management of the district. See the Explanatory Notes for a full listing of the legal policies affected. Recommended changes to local policies address the following topics:

- Board member requests for records and visits to campuses;
- Security of polling places;
- District investments;
- Criminal history for contractors and subcontractors;
- Prepaid meal card/accounts for students;
- Board delegation of certain termination actions;
- Employee standards of conduct, including electronic communications with students;

- Possession of firearms on locked vehicles in district parking areas;
- Cameras in special education classrooms;
- Parental notification of certain educator misconduct with students;
- Transportation funding for areas with a high risk of violence;
- Student issues, including attendance, bullying, mental health, and lice notification;
- Refusing entry to or ejecting persons from district property and visits by sex offenders to district premises;
- Responding to Public Information Act requests; and
- Opportunities for patriotic society representatives to speak to students.

Included in your Update 109 packet, please see the insert “Accessibility Changes to Your Online Policies and the Policy On Line® Application,” which explains changes you will see to your online policies and the Policy On Line application after adoption of Update 109 to address accessibility for people with disabilities.

Your Localized Update 109 packet also contains:

- **Explanatory Notes** describing the changes to each policy. Please note that, where appropriate, the Explanatory Notes ask you to verify that a particular policy reflects current district practice and to advise us of any changes needed so that our records and the district’s policy manual accurately track the district’s practice. Explanatory notes may also provide important information about policies not included in the update packet.
- ***Vantage Points—A Board Member’s Guide to Update 109***, which provides local officials a highly summarized first glance at the update. Please distribute the enclosed copies of *Vantage Points* to your board members with the review copies of the update.
- **Instructions** for incorporating this update into each of the district’s Localized Policy Manuals after board adoption. Use the enclosed Instruction Sheet as a guide to which policies should be added, replaced, and removed from your manual.

(LEGAL) vs. (LOCAL) Policies: Remember the Difference

(LEGAL) policies:

- Reflect the ever-changing legal context for governance and management of the district
- Should inform local decision making
- Should NOT be adopted, but only reviewed

(LOCAL) policies:

- Require close attention by both the administration and the board
- Must reflect the practices of the district and the intentions of the board
- May only be changed by board action (adopt, revise, or repeal)

If your board adopts changes to the (LOCAL) policies contained in this packet, please notify your policy consultant.

How to Place Policy Changes on the Agenda for Board Action

Board action on Localized Update 109 must occur within a properly posted, open meeting of the board.

- Update 109 may be addressed on the agenda posting as “Policy Update 109, affecting (LOCAL) policies (see attached list of codes).”
- You may use the “Agenda Posting (LOCAL) Policy List” provided online in *Local Manual Updates* and attach that list to the posting, or you may compile a list of (LOCAL) policy codes, titles, and subtitles from the material provided below.
- **BoardBook** compilers should use “Policy Update 109, affecting (LOCAL) policies” as the agenda item and, as agenda sub-items, the policy code, title, and subtitle of each of the (LOCAL) policies affected by the update.
- Here is a suggested motion for board action on Localized Update 109:
“I move that the board add, revise, or delete (LOCAL) policies as recommended by TASB Policy Service and according to the Instruction Sheet for TASB Localized Policy Manual Update 109 [with the following changes:]”

How to Notify Policy Service of Board Action

Notify Policy Service of the board's action on Update 109 using the Update 109 Adoption Notification Form, enclosed, so Policy Service records remain accurate.

How to Keep Minutes

The board's action on Localized Update 109 must be reflected in board minutes. Your minutes should include:

- The list of proposed (LOCAL) policy actions, such as the Instruction Sheet—annotated to reflect any changes made by the board
- The Explanatory Notes for the update (filed as an attachment to the minutes)
- Copies of new, replaced, or rescinded (LOCAL) policies

How to Maintain Your Historical Record

To construct a separate historical record of the manual, you must track the history of individual (LOCAL) policies. You should maintain a permanent historical record of every (LOCAL) policy adopted, revised, or rescinded by the board.

At a minimum, this record should include the following key pieces of information:

- Policy code
- Date of board action
- Text of policy

For more guidance on maintaining this record, please refer to:

- [*The Administrator's Guide to Policy Management*](#)
- [Tutorial videos](#) on handling an update

These guides are available in the myTASB *Policy Service Resource Library*.

How to Keep Your Administrative Regulations Current

Inspect your administrative procedures and documents—including EXHIBITS, REGULATIONS, handbooks, and guides—that may be affected by Update 109 policy changes.

If you must make changes to the REGULATIONS or EXHIBITS contained in your board policy manual, please notify your policy consultant.

Disclaimer and Copyright

PLEASE NOTE: This information is provided for educational purposes only to facilitate a general understanding of the law or other regulatory matter. This information is neither an exhaustive treatment on the subject nor is this intended to substitute for the advice of an attorney or other professional adviser. Consult with your attorney or professional adviser to apply these principles to specific fact situations.

Entire localized update packet © 2017 Texas Association of School Boards, Inc. All rights reserved.

Instruction Sheet

TASB Localized Policy Manual Update 109

District Lamar CISD

Code	Action To Be Taken	Note
ATTN (NOTE)	No policy enclosed	See explanatory note
A (LEGAL)	Replace table of contents	Revised table of contents
AE (LEGAL)	Replace policy	Revised policy
AE (EXHIBIT)	DELETE exhibit	See explanatory note
AF (LEGAL)	Replace policy	Revised policy
AIA (LEGAL)	Replace policy	Revised policy
AIB (LEGAL)	Replace policy	Revised policy
AIC (LEGAL)	Replace policy	Revised policy
BAA (LEGAL)	Replace policy	Revised policy
BBD (LEGAL)	Replace policy	Revised policy
BBE (LEGAL)	Replace policy	Revised policy
BBE (LOCAL)	Replace policy	Revised policy
BBFA (LEGAL)	Replace policy	Revised policy
BDAE (LEGAL)	Replace policy	Revised policy
BE (LEGAL)	Replace policy	Revised policy
BEC (LEGAL)	Replace policy	Revised policy
BG (LEGAL)	ADD policy	See explanatory note
BJA (LEGAL)	Replace policy	Revised policy
BJCD (LEGAL)	Replace policy	Revised policy
BR (LEGAL)	Replace policy	Revised policy
CCF (LEGAL)	Replace policy	Revised policy
CDA (LEGAL)	Replace policy	Revised policy
CDA (LOCAL)	Replace policy	Revised policy
CE (LEGAL)	Replace policy	Revised policy
CFA (LEGAL)	Replace policy	Revised policy
CH (LEGAL)	Replace policy	Revised policy
CI (LEGAL)	Replace policy	Revised policy
CJA (LEGAL)	Replace policy	Revised policy
CKC (LEGAL)	Replace policy	Revised policy
CKC (LOCAL)	Replace policy	Revised policy
CKE (LEGAL)	Replace policy	Revised policy
CL (LEGAL)	Replace policy	Revised policy

Instruction Sheet
TASB Localized Policy Manual Update 109

CLA	(LEGAL)	Replace policy	Revised policy
CLC	(LEGAL)	Replace policy	Revised policy
CMD	(LEGAL)	Replace policy	Revised policy
CNA	(LEGAL)	Replace policy	Revised policy
CNA	(LOCAL)	Replace policy	Revised policy
CNC	(LEGAL)	Replace policy	Revised policy
CO	(LEGAL)	Replace policy	Revised policy
CO	(LOCAL)	Replace policy	Revised policy
CQA	(LEGAL)	Replace policy	Revised policy
CRB	(LEGAL)	Replace policy	Revised policy
CRE	(LEGAL)	Replace policy	Revised policy
CV	(LEGAL)	Replace policy	Revised policy
CV	(EXHIBIT)	DELETE exhibit	See explanatory note
DBA	(LEGAL)	Replace policy	Revised policy
DC	(LEGAL)	Replace policy	Revised policy
DEC	(LEGAL)	Replace policy	Revised policy
DECA	(LEGAL)	Replace policy	Revised policy
DECB	(LEGAL)	Replace policy	Revised policy
DF	(LEGAL)	Replace policy	Revised policy
DF	(LOCAL)	ADD policy	See explanatory note
DFBA	(LEGAL)	Replace policy	Revised policy
DFE	(LEGAL)	Replace policy	Revised policy
DH	(LEGAL)	Replace policy	Revised policy
DH	(LOCAL)	Replace policy	Revised policy
DHB	(LEGAL)	Replace policy	Revised policy
DI	(EXHIBIT)	DELETE exhibit	See explanatory note
DMA	(LEGAL)	Replace policy	Revised policy
DNA	(LEGAL)	Replace policy	Revised policy
DNB	(LEGAL)	Replace policy	Revised policy
DP	(LEGAL)	Replace policy	Revised policy
EB	(LEGAL)	Replace policy	Revised policy
EC	(LEGAL)	Replace policy	Revised policy
EF	(LEGAL)	Replace policy	Revised policy
EFA	(LEGAL)	Replace policy	Revised policy

Instruction Sheet
TASB Localized Policy Manual Update 109

EHAA (LEGAL)	Replace policy	Revised policy
EHAD (LEGAL)	Replace policy	Revised policy
EHB (LEGAL)	Replace policy	Revised policy
EHBAB (LEGAL)	Replace policy	Revised policy
EHBAD (LEGAL)	Replace policy	Revised policy
EHBAE (LEGAL)	Replace policy	Revised policy
EHBAF (LEGAL)	Replace policy	Revised policy
EHBAF (LOCAL)	Replace policy	Revised policy
EHBC (LEGAL)	Replace policy	Revised policy
EHBG (LEGAL)	Replace policy	Revised policy
EHBK (LEGAL)	Replace policy	Revised policy
EHDD (LEGAL)	Replace policy	Revised policy
EHDE (LEGAL)	Replace policy	Revised policy
EIE (LEGAL)	Replace policy	Revised policy
EIF (LEGAL)	Replace policy	Revised policy
EJ (LEGAL)	Replace policy	Revised policy
EJ (LOCAL)	DELETE policy	See explanatory note
EK (LEGAL)	Replace policy	Revised policy
EKB (LEGAL)	Replace policy	Revised policy
EL (LEGAL)	Replace policy	Revised policy
FB (LEGAL)	Replace policy	Revised policy
FBA (LEGAL)	Replace policy	Revised policy
FD (LEGAL)	Replace policy	Revised policy
FDA (LEGAL)	Replace policy	Revised policy
FDB (LEGAL)	Replace policy	Revised policy
FEA (LEGAL)	Replace policy	Revised policy
FEA (LOCAL)	Replace policy	Revised policy
FFA (LEGAL)	Replace policy	Revised policy
FFA (LOCAL)	Replace policy	Revised policy
FFAB (LEGAL)	Replace policy	Revised policy
FFAD (LEGAL)	Replace policy	Revised policy
FFB (LEGAL)	Replace policy	Revised policy
FFC (LEGAL)	Replace policy	Revised policy
FFEA (LEGAL)	Replace policy	Revised policy

Instruction Sheet

TASB Localized Policy Manual Update 109

FFF	(LEGAL)	Replace policy	Revised policy
FFF	(LOCAL)	ADD policy	See explanatory note
FFG	(LEGAL)	Replace policy	Revised policy
FFI	(LEGAL)	Replace policy	Revised policy
FFI	(LOCAL)	Replace policy	Revised policy
FL	(LEGAL)	Replace policy	Revised policy
FM	(LEGAL)	Replace policy	Revised policy
FNCG	(LEGAL)	Replace policy	Revised policy
FNCH	(LEGAL)	DELETE policy	See explanatory note
FNG	(LEGAL)	Replace policy	Revised policy
FO	(LEGAL)	Replace policy	Revised policy
FOB	(LEGAL)	Replace policy	Revised policy
FOC	(LEGAL)	Replace policy	Revised policy
FOCA	(LEGAL)	Replace policy	Revised policy
FOD	(LEGAL)	Replace policy	Revised policy
FP	(LEGAL)	Replace policy	Revised policy
G	(LEGAL)	Replace table of contents	Revised table of contents
GBA	(LEGAL)	Replace policy	Revised policy
GBAA	(LEGAL)	Replace policy	Revised policy
GBAA	(LOCAL)	Replace policy	Revised policy
GBAA	(REGULATION)	Review regulation	Revise as necessary
GKA	(LEGAL)	Replace policy	Revised policy
GKA	(LOCAL)	Replace policy	Revised policy
GKB	(LEGAL)	Replace policy	Revised policy
GKC	(LEGAL)	Replace policy	Revised policy
GKC	(LOCAL)	Replace policy	Revised policy
GKE	(LEGAL)	ADD policy	See explanatory note
GKE	(LOCAL)	ADD policy	See explanatory note
GKG	(LEGAL)	Replace policy	Revised policy
GRAA	(LEGAL)	Replace policy	Revised policy

PUBLIC EDUCATION MISSION, GOALS, AND OBJECTIVES

The mission of the Texas public education system is to ensure that all Texas children have access to a quality education that enables them to achieve their full potential and fully participate now and in the future in the social, economic, and educational opportunities in our state and nation. That mission is grounded on the conviction that a general diffusion of knowledge is essential for the welfare of Texas and for the preservation of the liberties and rights of Texas citizens. It is further grounded on the conviction that a successful public education system is directly related to a strong, dedicated, and supportive family and that parental involvement in the school is essential for the maximum educational achievement of a child. The objectives of public education are:

OBJECTIVE 1: Parents will be full partners with educators in the education of their children.

OBJECTIVE 2: Students will be encouraged and challenged to meet their full educational potential.

OBJECTIVE 3: Through enhanced dropout prevention efforts, all students will remain in school until they obtain a diploma.

OBJECTIVE 4: A well-balanced and appropriate curriculum will be provided to all students.

OBJECTIVE 5: Educators will prepare students to be thoughtful, active citizens who have an appreciation for the basic values of our state and national heritage and who can understand and productively function in a free enterprise society.

OBJECTIVE 6: Qualified and highly effective personnel will be recruited, developed, and retained.

OBJECTIVE 7: Texas students will demonstrate exemplary performance in comparison to national and international standards.

OBJECTIVE 8: School campuses will maintain a safe and disciplined environment conducive to student learning.

OBJECTIVE 9: Educators will keep abreast of the development of creative and innovative techniques in instruction and administration using those techniques as appropriate to improve student learning.

OBJECTIVE 10: Technology will be implemented and used to increase the effectiveness of student learning, instructional management, staff development, and administration.

The academic goals of public education are to serve as a foundation for a well-balanced and appropriate education. The students in the public education system will demonstrate exemplary performance in:

GOAL 1: The reading and writing of the English language.

GOAL 2: The understanding of mathematics.

GOAL 3: The understanding of science.

GOAL 4: The understanding of social studies.

Education Code 4.001, 4.002

CURRENT

BOARD MEMBERS AUTHORITY

BBE
(LOCAL)

BOARD AUTHORITY

The Board has final authority to determine and interpret the policies that govern the schools and, subject to the mandates and limits imposed by state and federal authorities, has complete and full control of the District. Board action shall be taken only in meetings that comply with the Open Meetings Act. [See BE(LEGAL)]

TRANSACTIONING BUSINESS

When a proposal is presented to the Board, the Board shall hold a discussion and reach a decision. Although there may be dissenting votes, which are a matter of public record, each Board decision shall be an action by the whole Board binding upon each member.

INDIVIDUAL AUTHORITY FOR COMMITTING THE BOARD

Board members as individuals shall not exercise authority over the District, its property, or its employees. Except for appropriate duties and functions of the Board President, an individual member may act on behalf of the Board only with the express authorization of the Board. Without such authorization, no individual member may commit the Board on any issue. [See BDAA]

INDIVIDUAL ACCESS TO INFORMATION

An individual Board member, acting in his or her official capacity, shall have the right to seek information pertaining to District fiscal affairs, business transactions, governance, and personnel matters, including information that properly may be withheld from members of the general public in accordance with the Public Information Chapter of the Government Code. [See GBA]

LIMITATIONS

If a Board member is not acting in his or her official capacity, the Board member has no greater right to District records than a member of the public.

An individual Board member shall not have access to confidential student records unless the member is acting in his or her official capacity and has a legitimate educational interest in the records in accordance with policy FL.

A Board member who is denied access to a record under this provision may ask the Board to determine whether the record should be provided or may file a request under the Public Information Act. [See GBAA]

REQUESTS FOR RECORDS

An individual Board member shall seek access to records or request copies of records from the Superintendent or other designated custodian of records. When a custodian of records other than the Superintendent provides access to records or copies of records to an individual Board member, the provider shall inform the Superintendent of the records provided.

In accordance with law, the District shall track and report any requests under this provision, including the cost of responding to one or more requests by any individual Board member for 200 or more pages of material in a 90-day period.

BOARD MEMBERS
AUTHORITY

BBE
(LOCAL)

REQUESTS FOR
REPORTS

No individual Board member shall direct or require District employees to prepare reports derived from an analysis of information in existing District records or to create a new record compiled from information in existing District records. Directives to the Superintendent or other custodian of records regarding the preparation of reports shall be by Board action.

CONFIDENTIALITY

At the time a Board member is provided access to confidential records or to reports compiled from such records, the Superintendent or other District employee shall advise the Board member of the responsibility to comply with confidentiality requirements.

REFERRING
COMPLAINTS

If employees, parents, students, or other members of the public bring concerns or complaints to an individual Board member, he or she shall refer them to the Superintendent or another appropriate administrator, who shall proceed according to the applicable complaint policy. [See (LOCAL) policies at DGBA, FNG, and GF]

When the concern or complaint directly pertains to the Board's own actions or policy, for which there is no administrative remedy, the Board member may request that the issue be placed on the agenda.

Board Authority

The Board has final authority to determine and interpret the policies that govern the schools and, subject to the mandates and limits imposed by state and federal authorities, has complete and full control of the District. Board action shall be taken only in meetings that comply with the Open Meetings Act. [See BE(LEGAL)]

**Transacting
Business**

When a proposal is presented to the Board, the Board shall hold a discussion and reach a decision. Although there may be dissenting votes, which are a matter of public record, each Board decision shall be an action by the whole Board binding upon each member.

**Individual Authority
for Committing the
Board**

Board members as individuals shall not exercise authority over the District, its property, or its employees. Except for appropriate duties and functions of the Board President, an individual member may act on behalf of the Board only with the express authorization of the Board. Without such authorization, no individual member may commit the Board on any issue. [See BDAA]

**Individual Access to
Information**

An individual Board member, acting in his or her official capacity, shall have the right to seek information pertaining to District fiscal affairs, business transactions, governance, and personnel matters, including information that properly may be withheld from members of the general public in accordance with the Public Information Chapter of the Government Code. [See GBA]

Limitations

If a Board member is not acting in his or her official capacity, the Board member has no greater right to District records than a member of the public.

An individual Board member shall not have access to confidential student records unless the member is acting in his or her official capacity and has a legitimate educational interest in the records in accordance with policy FL.

A Board member who is denied access to a record under this provision may ask the Board to determine whether the record should be provided or may file a request under the Public Information Act. [See GBAA]

**Requests for
Records**

An individual Board member shall seek access to records or request copies of records from the Superintendent or other designated custodian of records, who shall respond within the time frames required by law. When a custodian of records other than the Superintendent provides access to records or copies of records to an individual Board member, the provider shall inform the Superintendent of the records provided.

In accordance with law, the District shall track and report any requests under this provision, including the cost of responding to one

BOARD MEMBERS
AUTHORITY

BBE
(LOCAL)

or more requests by any individual Board member for 200 or more pages of material in a 90-day period.

Requests for
Reports

No individual Board member shall direct or require District employees to prepare reports derived from an analysis of information in existing District records or to create a new record compiled from information in existing District records. Directives to the Superintendent or other custodian of records regarding the preparation of reports shall be by Board action.

Confidentiality

At the time a Board member is provided access to confidential records or to reports compiled from such records, the Superintendent or other District employee shall advise the Board member of the responsibility to comply with confidentiality requirements.

Referring
Complaints

If employees, parents, students, or other members of the public bring concerns or complaints to an individual Board member, he or she shall refer them to the Superintendent or another appropriate administrator, who shall proceed according to the applicable complaint policy. [See (LOCAL) policies at DGBA, FNG, and GF]

When the concern or complaint directly pertains to the Board's own actions or policy, for which there is no administrative remedy, the Board member may request that the issue be placed on the agenda.

Visits to District
Facilities

A Board member shall adhere to any posted requirements for visitors to first report to the main office of a District facility, including a school campus. Visits during the school or business day shall not be permitted if their duration or frequency interferes with the delivery of instruction or District operations. [See also GKC]

CURRENT

OTHER REVENUES INVESTMENTS

CDA
(LOCAL)

POLICY	It is the policy of the District to invest public funds in a manner that ensures the safety of invested funds, maintains sufficient liquidity to provide for the daily needs of the District, and achieves maximum yield in relation to the risk assumed. Safety of invested principal, however, remains highest in priority.
INVESTMENT AUTHORITY	The chief financial officer, the budget and treasury officer, and the director of finance shall serve as the investment officers of the District and shall invest District funds as directed by the Board and in accordance with the District's written investment policy and generally accepted accounting procedures.
SCOPE	This investment policy applies to all financial assets of the District. These funds are accounted for in the District's comprehensive annual financial report and include:
GENERAL FUND	The general fund usually includes transactions as a result of revenues from local maintenance taxes, Foundation School Program entitlements, and other locally generated sources.
SPECIAL REVENUE FUNDS	Special revenue funds are governmental funds used to account for the proceeds of specific revenue sources that are legally restricted to expenditures for specified purposes.
DEBT SERVICE FUNDS	A debt service fund is a governmental fund, with budgetary control, that must be used to account for general long-term debt principal and interest for debt issues and other long-term debts for which a tax has been dedicated.
CAPITAL PROJECTS FUNDS	A capital projects fund is a governmental fund that must be used to account, on a project basis, for projects financed by the proceeds from bond issues, or for capital projects otherwise mandated to be accounted for in this fund.
INTERNAL SERVICE FUNDS	Internal service funds are proprietary funds accounted for on the accrual basis.
TRUST AND AGENCY FUNDS	This group of funds is used to account for assets held by a school district in a trustee capacity of the District, or as an agent for individuals, private organizations, other governmental units and/or other funds. This fund type consists of expendable trust funds, non-expendable trust funds, pension trust funds and agency funds.
TEXAS TEACHER RETIREMENT FUND	<p>The Texas Teacher Retirement Fund shall not be covered by this policy.</p> <p>All employees of the District employed for one-half or more of the standard work load, and who are not exempted from membership under Government Code, Section 822.002, are required to participate in the Teacher Retirement System of Texas, a multiple-</p>

OTHER REVENUES
INVESTMENTS

CDA
(LOCAL)

employer public employee retirement system. It is a cost-sharing public employee retirement system with one exception—all risks and costs are not shared by the District, but are the liability of the state of Texas, and as such, all investments are maintained by the Teacher Retirement System.

OBJECTIVES

The primary objectives, in priority order, of investment activities shall be safety, liquidity, and yield:

SAFETY

1. Safety of principal is the foremost objective of the investment program. Investments shall be undertaken in a manner that seeks to ensure the preservation of capital in the overall portfolio. The objective will be to mitigate credit risk and interest rate risk.
 - a. The District will minimize credit risk, which is the risk of loss due to the failure of the security issuer or backer, by:
 - (1) Limiting investments to the types of securities listed in this investment policy;
 - (2) Pre-qualifying the financial institutions, brokers/dealers, and advisors with which the District will do business in accordance with this policy; and
 - (3) Diversifying the investment portfolio so that the impact of potential losses from any one type of security or from any one individual issuer will be minimized.
 - b. To reduce exposure to changes in interest rates that could adversely affect the value of investments, the District shall use final and weighted-average-maturity limits and diversification.

The District shall monitor interest rate risk using weighted average maturity and specific identification.

LIQUIDITY

2. The investment portfolio shall remain sufficiently liquid to meet all operating requirements that may be reasonably anticipated. This is accomplished by structuring the portfolio so that securities mature concurrent with cash needs to meet anticipated demands (static liquidity). Furthermore, since all possible cash demands cannot be anticipated, the portfolio should consist largely of securities with active secondary or resale markets (dynamic liquidity). Alternatively, a portion of the portfolio may be placed in money market mutual funds or local government investment pools that offer same-day liquidity for short-term funds.

OTHER REVENUES
INVESTMENTS

CDA
(LOCAL)

YIELD

3. The investment portfolio shall be designed with the objective of attaining a market rate of return throughout budgetary and economic cycles, taking into account the investment risk constraints and liquidity needs. Return on investment is of secondary importance compared to the safety and liquidity objectives described above. The core of investments are limited to relatively low risk securities in anticipation of earning a fair return relative to the risk being assumed. Securities shall generally be held until maturity with the following exceptions:
 - a. A security with declining credit may be sold early to minimize loss of principal.
 - b. A security swap would improve the quality, yield, or target duration in the portfolio.
 - c. Liquidity needs of the portfolio require that the security be sold.

FUND STRATEGIES

Appropriate investment strategies shall be developed by fund category. The strategies must define the investment objectives for each fund type, with priority consideration being given to the suitability of the investment for the type of funds being invested, the preservation and safety of principal, liquidity, marketability, diversification, and yield. Investments shall be made in accordance with these objectives, and the maximum allowable stated maturity for any individual security may exceed one year provided legal limits are not exceeded.

The District shall have a similar investment strategy for each of the following covered funds:

1. General fund.
2. Special revenue fund(s)—including funds used to account for federal, state, and local grants, as well as the food service fund and the campus activity fund.
3. Debt service fund(s).
4. Capital project fund(s).
5. Proprietary fund(s)—including the funds used to account for the workers' compensation and medical self-insurance programs.
6. Trust and agency funds-including the student activity fund.

The District shall follow the investment strategies listed below (in order of importance) for each covered fund:

OTHER REVENUES
INVESTMENTS

CDA
(LOCAL)

1. Each investment option shall be reviewed to ensure understanding of the suitability of the investment to the financial requirements of the District;
2. Investments shall be selected that provide preservation and safety of invested funds;
3. Investment strategies for all covered funds shall have as their objective sufficient investment liquidity to timely meet obligations. Maturities longer than one year are authorized provided legal limits are not exceeded;
4. The investment shall be marketable if the need arises to liquidate invested funds before maturity;
5. The investment type shall be consistent with the Board's desired diversification of the investment portfolio; and
6. All invested funds of the District shall attain a rate of return commensurate with the District's investment risk constraints and the cash flow characteristics of the portfolio.

The District shall diversify its investments in all funds by security type and institution. The District shall consider purchase of high quality short-term to medium-term securities that will complement each other in a laddered or liability-matching portfolio structure.

PRUDENCE

Investments shall be made with judgment and care—under circumstances then prevailing which persons of prudence, discretion and intelligence exercise in the management of their own affairs, not for speculation, but for investment, considering the probable safety of their capital as well as the probable income to be derived.

The standard of prudence to be used by investment officials shall be the “prudent person” standard and shall be applied in the context of managing an overall portfolio. Investment officers acting in accordance with written procedures and the investment policy and exercising due diligence shall be relieved of personal responsibility for an individual security's credit risk or market price changes, provided deviations from expectations are reported in a timely fashion and appropriate action is taken to control adverse developments.

In determining whether an investment official has exercised prudence with respect to an investment decision, the determination shall be made taking into consideration the investment of all funds over which the official had responsibility rather than consideration as to the prudence of a single investment and, whether the investment decision was consistent with the District's investment policy and written investment procedures.

OTHER REVENUES
INVESTMENTS

CDA
(LOCAL)

ETHICS AND
CONFLICTS OF
INTEREST

Officers and employees involved in the investment process shall refrain from personal business activity that could conflict with proper execution of the investment program, or which could impair their ability to make impartial investment decisions.

Officers and employees involved in the investment process shall sign annual statements agreeing to abide by this section of the investment policy and affirming no known conflicts of interest.

An officer or employee involved in the investment process has a personal business relationship with a business organization if:

1. The officer or employee owns ten percent or more of the voting stock or shares of the business organization or owns \$5,000 or more of the fair market value of the business organization;
2. Funds received by the officer or employee from the business organization exceed ten percent of his/her gross income for the previous year;
3. The officer or employee has acquired from the business organization during the previous year investments with a book value of \$2,500 or more for his/her personal account; or
4. The officer is related within the second degree by affinity or consanguinity, as determined under Chapter 573 of the Texas Government Code, to an individual seeking to transact investment business with the entity.

If the investment officer has a personal business relationship with a business organization, a disclosure statement must be filed with the Texas Ethics Commission.

AUTHORIZED
INVESTMENTS

From those investments authorized by law and described in CDA(LEGAL), the Board shall permit investment of District funds in the following investment types only, consistent with the strategies and maturities defined in this policy:

1. Obligations of the United States or its agencies and instrumentalities; direct obligations of the state of Texas or its agencies; other obligations, the principal and interest of which are unconditionally guaranteed or insured by, or backed by the full faith and credit of the state of Texas, the United States, or its instrumentalities; including obligations that are fully guaranteed or insured by the Federal Deposit Insurance Corporation (FDIC) or by the explicit full faith and credit of the United States; obligations of states, agencies, counties, cities, and other political subdivisions of any state rated as to investment

quality by a nationally recognized investment rating firm not less than A or its equivalent. *Gov't Code 2256.009*

2. Certificates of deposit or share certificates issued by a depository institution that has its main office or a branch office in Texas that is guaranteed or insured by the FDIC or its successor or the National Credit Union Share Insurance Fund or its successor and is secured by obligations described in item 1 above, including mortgage-backed securities directly issued by a federal agency or instrumentality that have a market value of not less than the principal amount of the certificates or are secured in any other manner and amount provided by law for the deposits of the investment entity. *Gov't Code 2256.010*

In addition to the authority to invest funds in certificates of deposit under the previous section, an investment in certificates of deposit made in accordance with the following conditions is an authorized investment under Government Code 2256.010:

- a. The funds are invested by the District through a broker that has its main office or a branch office in this state and is selected from a list adopted by the District as required by Government Code 2256.025, or a depository institution that has its main office or a branch office in this state and that is selected by the District;
- b. The broker or depository institution selected by the District arranges for the deposit of the funds in certificates of deposit in one or more federally insured depository institutions, wherever located, for the account of the District;
- c. The full amount of the principal and accrued interest of each of the certificates of deposit is insured by the United States or an instrumentality of the United States; and
- d. The District appoints the depository institution selected by the District, an entity described by Government Code 2257.041(d), or a clearing broker-dealer registered with the Securities and Exchange Commission and operating pursuant to Securities and Exchange Commission Rule 15c3-3 (17 C.F.R. Section 240.15c3-3) as custodian for the District with respect to the certificates of deposit issued for the account of the District entity.

Gov't Code 2256.010(b)

3. Fully collateralized repurchase agreements that have a defined termination date, are secured by a combination of cash and obligations of the United States or its agencies and in-

strumentalities, require the securities being purchased by the District or cash held by the District to be pledged to the District, held in the District's name, and deposited with a third party selected and approved by the investment committee, and placed through a primary government securities dealer, as defined by the Federal Reserve or a financial institution doing business in the State of Texas. *Gov't Code 2256.011*

The District shall have a master repurchase agreement signed with the bank or dealer with whom all repurchase agreements are traded.

4. Commercial paper that has a stated maturity of 270 days or fewer from the date of issuance and is rated not less than A1-1 or P-1 or an equivalent rating by at least two nationally recognized credit rating agencies or by one nationally recognized credit rating agency provided the commercial paper is fully secured by an irrevocable letter of credit issued by a bank organized and existing under U.S. law or the law of any state; and to the extent that commercial paper is held through an investment pool and not as an individual issue through the District. *Gov't Code 2256.013.*
5. No-load money market mutual funds that are regulated by the Securities and Exchange Commission, and have a dollar-weighted average stated maturity of 90 days or fewer, are invested exclusively in obligations described by items 1–4 above, and include in their investment objectives the maintenance of a stable net asset value of \$1 for each share. Investments in mutual funds shall be limited to the percentages authorized by Government Code 2256.014(c). *Gov't Code 2256.014.*
6. A public funds investment pool meeting the requirements of Government Code 2256.016, are rated no lower than AAA or an equivalent rating by at least one nationally recognized rating service, and are authorized by resolution or ordinance by the Board. In addition, a local government investment pool created to function as a money market mutual fund must mark its portfolio to the market daily and, to the extent reasonably possible, stabilize at \$1 net asset value. *Gov't Code 2256.016.*
7. Guaranteed investment contracts that have a defined termination date and are secured by obligations described by Government Code 2256.09(a)(1), excluding those obligations described by Government Code 2256.09(b), in an amount at least equal to the amount of bond proceeds invested under the contract; such obligations must be pledged to the District

OTHER REVENUES
INVESTMENTS

CDA
(LOCAL)

and held in the District's name with an approved third party.
Gov't Code 2256.015.

Corporate bonds are not an eligible investment for a public funds investment pool. *Gov't Code 2256.0204(g)*

AUTHORIZED
BROKERS / DEALERS

The investment officers will maintain a list of financial institutions, approved by the investment committee, who are authorized to provide investment services. In addition, a list will also be maintained of approved security brokers/dealers selected by credit-worthiness who are authorized to provide investment services in the state of Texas. These may include primary dealers or regional dealers that qualify under Securities and Exchange Commission Rule 15C3-1 (uniform net capital rule).

All financial institutions and brokers/dealers who desire to become qualified bidders for investment transactions must supply the investment officers with the following:

1. Audited financial statements
2. Proof of Financial Industry Regulatory Authority (FINRA) certification
3. Trading resolution
4. Proof of registration in the state of Texas
5. Completed broker/dealer questionnaire
6. Certification of having read the District's investment policy

This information will be reviewed by the investment officers and a recommendation for addition to the list of approved bidders will be submitted to the investment committee for approval.

A periodic review, at least annually, of the financial condition and registration of new qualified bidders will be conducted by the investment committee. Recommendations will be provided for consideration by the Board as necessary.

MONITORING MARKET
PRICES

The investment officers shall keep the Board informed of significant declines in the market value of the District's investment portfolio. Information sources may include financial/investment publications and electronic media, available software for tracking investments, commercial or investment banks, financial advisors, and representatives/advisors of investment pools or money market funds. Monitoring shall be done monthly or more often as economic conditions warrant by using appropriate reports, indices, or benchmarks for the type of investment.

OTHER REVENUES
INVESTMENTS

CDA
(LOCAL)

MONITORING RATING
CHANGES

In accordance with Government Code 2256.005(b), the investment officers shall develop a procedure to monitor changes in investment ratings and to liquidate investments that do not maintain satisfactory ratings.

SELECTION OF
DEPOSITORY

The Board shall select and designate a depository institution in accordance with CDA(LEGAL) and (LOCAL). The depository shall be selected based upon its solvency and stability of leadership as well as on the services provided. The depository shall be selected through a formalized bidding process in response to the District's request for bid (RFB) outlining all services required. Such services should provide the greatest flexibility for money management and should include online account management, positive pay accounts, purchasing card capabilities, and other services considered necessary by District management.

The District shall have the discretion to determine the time span for rebidding the depository contract; however, a three-year period will be the maximum length of time between bidding.

COMPETITIVE
BIDDING

It is the strategy of the District to require competitive bidding for all individual security purchases and sales except for:

1. Transactions with money market mutual funds and local government investment pools (which are deemed to be made at prevailing market rates);
2. Treasury and agency securities purchased at issue through an approved broker/dealer or financial institution; or
3. Automatic overnight "sweep" transactions with the District Depository.

At least three bids or offers must be solicited for all other transactions involving individual securities. The District's investment advisor is also required to solicit at least three bids or offers when transacting trades on the District's behalf. In situations where other dealers do not offer the exact security being offered, offers on the closest comparable investment may be used to establish a fair market price for the security.

COLLATERAL

The investment officers shall ensure that all District funds (principal and accrued interest) are fully collateralized to 110 percent or insured in one or more of the following manners:

1. FDIC insurance coverage; and/or
2. 110 percent of the uninsured value in obligations of the United States or its agencies or instrumentalities or other authorized securities as outlined in item 4 below.

OTHER REVENUES
INVESTMENTS

CDA
(LOCAL)

3. All pledged securities shall be held in safekeeping by the District, in a custodial account approved by the District in a third party financial institution, or with a Federal Reserve Bank. The third party custodian shall be required to issue safekeeping receipts directly to the District and to provide a monthly listing of each specific security, rate, description, maturity, CUSIP number, and other information as may be deemed necessary and appropriate by the District. In order to anticipate market changes and provide a level of additional security for all funds, the collateralization level required shall be 110 percent of the market value. The bank shall be liable for pricing securities and providing 110 percent collateralization.
4. Pledged securities shall be limited to only those items which are specifically permitted as approved investment instruments within the definitions of this policy. Should a pledged security fail to meet this requirement, it shall be the sole responsibility of the financial institution to immediately, without notice from the District or cost to the District, replace any such nonconforming security.

SAFEKEEPING AND
CUSTODY

Safekeeping and custody of securities and collateral shall be in accordance with state law. It shall be the District's intent to place securities and collateral in the possession of a third party custodian designated by the District where feasible, and held in the District's name as evidenced by safekeeping receipts of the institution with which the securities are deposited.

All investment transactions except investment pool funds and mutual funds will be executed by delivery vs. payment (DVP) to ensure that securities are deposited in an eligible financial institution prior to the release of funds. That is, funds shall not be wired or paid until verification has been made that the Trustee received the securities or collateral.

DIVERSIFICATION

The District shall diversify its investments by security type and institution. The asset mix of the District's portfolio is expressed in terms of maximum commitment so as to allow sufficient flexibility to take advantage of market considerations within the context of this policy. The asset mix requirements are as follows:

Money Market Accounts	60% (maximum)
Certificates of Deposit	25% (maximum)
U.S. Treasury Obligations	100% (maximum)
U.S. Government Securities	100% (maximum)
Repurchase Agreements	15% (maximum)
Public Funds Investment Pools	100% (maximum)

OTHER REVENUES
INVESTMENTS

CDA
(LOCAL)

Commercial Paper	25% (maximum)
Guaranteed Investment Contracts	60% (maximum)

MAXIMUM MATURITY

To the extent possible, the District shall attempt to match its investments with anticipated cash flow requirements. Unless matched to a specific cash flow, the District shall not directly invest in securities maturing more than 36 months from the date of purchase. However, securities with a maturity of greater than 12 months shall not exceed ten percent of the total portfolio, and shall be approved by the Board before purchase.

Bond proceeds and debt service funds may be invested in securities exceeding 12 months if the maturity of such investments is made to coincide as nearly as practicable with the expected use of the funds.

ARBITRAGE

The Tax Reform Act of 1986 provided limitations restricting the amount of income that could be generated from the investment of tax-exempt General Obligation Bond proceeds and debt service income. The arbitrage rebate provisions require that the District compute earnings on investment from each issue of bonds on an annual basis to determine if a rebate is required. To determine the District's arbitrage position, the District is required to perform specific calculations relative to the actual yield earned on the investment of the funds and the yield that could have been earned if the funds had been invested at a rate equal to the yield on the bonds sold by the District. The rebate provision states that periodically (not less than once every five years, and not later than 60 days after the maturity of the bonds), the District is required to pay the U.S. Treasury a rebate of excess earnings based on the District being in a positive arbitrage position. The Tax Reform restrictions require precision in the monitoring and recording of investments as a whole, and particularly as relates to yields and computations so as to ensure compliance. Failure to comply can dictate that the bonds become taxable, retroactively from the date of issue.

The District's investment position relative to arbitrage is the continued pursuit of maximizing the yield on applicable investments while ensuring the safety of capital and liquidity. It is a fiscally sound position to continue maximization of yield and rebate excess earnings, if necessary.

BENCHMARK

The District's investment strategy is a passive one, in that the majority of securities shall be purchased and held to maturity. Additionally, cash inflows and outflows shall be monitored daily. Given this strategy, the basis used by the investment officers to determine whether market yields are being achieved shall be the Two-Year U.S. Treasury Bill and the average Fed Funds rate.

OTHER REVENUES
INVESTMENTS

CDA
(LOCAL)

INTERNAL CONTROL

The investment portfolio, as well as compliance with this policy, shall be reviewed quarterly by the investment committee and annually by the District's external auditor in conjunction with the annual audit of the District's financial statements.

INVESTMENT
COMMITTEE

The investment committee shall review the investment strategies annually and make recommendations for revision as necessary. The investment committee includes, but is not limited to, the Superintendent, the chief financial officer, the director of finance, the budget and treasury officer, the financial advisor, Board financial audit committee (nonvoting), and up to two investment bankers.

QUALITY OF
INVESTMENT
MANAGEMENT

Designated investment officers of the District shall participate in periodic training through courses and seminars offered by professional organizations, associations, and other independent sources approved by the investment committee to ensure the quality and capability of investment management in compliance with the Public Funds Investment Act.

INVESTMENT
TRAINING

Within 12 months after taking office or assuming duties, designated investment officers of the District shall attend at least one training session from an independent source approved either by the Board or by the investment committee advising the investment officers. This initial training must contain at least ten hours of instruction relating to their respective responsibilities under the Public Funds Investment Act. *Gov't Code 2256.008(a)*

The investment officers must also attend an investment training session not less than once in a two-year period that begins on the first day of the District's fiscal year and consists of the two consecutive fiscal years after that date, and receive not less than ten hours of instruction relating to investment responsibilities under the Public Funds Investment Act from an independent source approved by the Board or the investment committee advising the investment officers. If the District has contracted with another investing entity to invest the District's funds, this training requirement may be satisfied by having a Board officer attend four hours of appropriate instruction in a two-year period that begins on the first day of the District's fiscal year and consists of the two consecutive fiscal years after that date. *Gov't Code 2256.008(a), (b)*

Investment training shall include education in investment controls, security risks, strategy risks, market risks, diversification of investment portfolio, and compliance with the Government Code, Chapter 2256. *Gov't Code 2256.008(c)*

REPORTING

Investment performance shall be regularly monitored by investment staff and reported to the Board. Month-end market prices on each security will be obtained by the Budget and Treasury Officer

OTHER REVENUES
INVESTMENTS

CDA
(LOCAL)

from a variety of nationally recognized securities databases (e.g., the Wall Street Journal, Bloomberg, etc.). These prices will be recorded in the District's portfolio database and included in all management reports where necessary as well as the District's Comprehensive Annual Financial Report.

Not less than quarterly the investment officers will submit to the Board a written report of the status of the current investment portfolio. The report must meet the requirements of Chapter 2256 of the Government Code (Public Funds Investment Act) and:

1. Describe in detail the investment position of the District on the date of the report;
2. Be prepared jointly by all investment officers of the District;
3. Be signed by each investment officer of the District;
4. Contain a summary statement for each pooled fund group that states the beginning market value for the period and the ending market value for the period;
5. State the book value and market value of each separately invested asset at the end of the reporting period by the type of asset and type of fund, and type of institution;
6. Percent of portfolio by type of asset, fund, and institution will be provided;
7. State the maturity date of each separately invested asset that has a maturity date;
8. State the account or fund or pooled fund group for which each individual investment was acquired; and
9. State the compliance of the investment portfolio as it relates to the investment strategy and relevant provisions of this policy and the Public Funds Investment Act.

An independent auditor shall formally review the quarterly reports prepared under this section at least annually, and that auditor shall report the results of the review to the Board.

ANNUAL
COMPLIANCE
AUDIT

In conjunction with the annual financial audit, a compliance audit shall be performed that includes an audit of management controls on investments and adherence to the District's established policy.

INVESTMENT POLICY
APPROVAL

The District's investment policy shall be adopted by resolution of the Board. The policy shall be reviewed annually and approved by the Board.

Policy	It is the policy of the District to invest public funds in a manner that ensures the safety of invested funds, maintains sufficient liquidity to provide for the daily needs of the District, and achieves maximum yield in relation to the risk assumed. Safety of invested principal, however, remains highest in priority.
Investment Authority	The chief financial officer, the budget and treasury officer, and the director of finance shall serve as the investment officers of the District and shall invest District funds as directed by the Board and in accordance with the District's written investment policy and generally accepted accounting procedures.
Scope	This investment policy applies to all financial assets of the District. These funds are accounted for in the District's comprehensive annual financial report and include:
General Fund	The general fund usually includes transactions as a result of revenues from local maintenance taxes, Foundation School Program entitlements, and other locally generated sources.
Special Revenue Funds	Special revenue funds are governmental funds used to account for the proceeds of specific revenue sources that are legally restricted to expenditures for specified purposes.
Debt Service Funds	A debt service fund is a governmental fund, with budgetary control, that must be used to account for general long-term debt principal and interest for debt issues and other long-term debts for which a tax has been dedicated.
Capital Projects Funds	A capital projects fund is a governmental fund that must be used to account, on a project basis, for projects financed by the proceeds from bond issues, or for capital projects otherwise mandated to be accounted for in this fund.
Internal Service Funds	Internal service funds are proprietary funds accounted for on the accrual basis.
Trust and Agency Funds	This group of funds is used to account for assets held by a school district in a trustee capacity of the District, or as an agent for individuals, private organizations, other governmental units and/or other funds. This fund type consists of expendable trust funds, nonexpendable trust funds, pension trust funds and agency funds.
Texas Teacher Retirement Fund	<p>The Texas Teacher Retirement Fund shall not be covered by this policy.</p> <p>All employees of the District employed for one-half or more of the standard work load, and who are not exempted from membership under Government Code, Section 822.002, are required to participate in the Teacher Retirement System of Texas, a multiple-</p>

employer public employee retirement system. It is a cost-sharing public employee retirement system with one exception—all risks and costs are not shared by the District, but are the liability of the state of Texas, and as such, all investments are maintained by the Teacher Retirement System.

Objectives

The primary objectives, in priority order, of investment activities shall be safety, liquidity, and yield:

Safety

1. Safety of principal is the foremost objective of the investment program. Investments shall be undertaken in a manner that seeks to ensure the preservation of capital in the overall portfolio. The objective will be to mitigate credit risk and interest rate risk.
 - a. The District will minimize credit risk, which is the risk of loss due to the failure of the security issuer or backer, by:
 - (1) Limiting investments to the types of securities listed in this investment policy;
 - (2) Pre-qualifying the financial institutions, brokers/dealers, and advisors with which the District will do business in accordance with this policy; and
 - (3) Diversifying the investment portfolio so that the impact of potential losses from any one type of security or from any one individual issuer will be minimized.
 - b. To reduce exposure to changes in interest rates that could adversely affect the value of investments, the District shall use final and weighted-average-maturity limits and diversification.

The District shall monitor interest rate risk using weighted average maturity and specific identification.

Liquidity

2. The investment portfolio shall remain sufficiently liquid to meet all operating requirements that may be reasonably anticipated. This is accomplished by structuring the portfolio so that securities mature concurrent with cash needs to meet anticipated demands (static liquidity). Furthermore, since all possible cash demands cannot be anticipated, the portfolio should consist largely of securities with active secondary or resale markets (dynamic liquidity). Alternatively, a portion of the portfolio may be placed in money market mutual funds or local government investment pools that offer same-day liquidity for short-term funds.

Yield

3. The investment portfolio shall be designed with the objective of attaining a market rate of return throughout budgetary and economic cycles, taking into account the investment risk constraints and liquidity needs. Return on investment is of secondary importance compared to the safety and liquidity objectives described above. The core of investments are limited to relatively low risk securities in anticipation of earning a fair return relative to the risk being assumed. Securities shall generally be held until maturity with the following exceptions:
 - a. A security with declining credit may be sold early to minimize loss of principal.
 - b. A security swap would improve the quality, yield, or target duration in the portfolio.
 - c. Liquidity needs of the portfolio require that the security be sold.

Fund Strategies

Appropriate investment strategies shall be developed by fund category. The strategies must define the investment objectives for each fund type, with priority consideration being given to the suitability of the investment for the type of funds being invested, the preservation and safety of principal, liquidity, marketability, diversification, and yield. Investments shall be made in accordance with these objectives, and the maximum allowable stated maturity for any individual security may exceed one year provided legal limits are not exceeded.

The District shall have a similar investment strategy for each of the following covered funds:

1. General fund.
2. Special revenue fund(s)—including funds used to account for federal, state, and local grants, as well as the food service fund and the campus activity fund.
3. Debt service fund(s).
4. Capital project fund(s).
5. Proprietary fund(s)—including the funds used to account for the workers' compensation and medical self-insurance programs.
6. Trust and agency funds—including the student activity fund.

The District shall follow the investment strategies listed below (in order of importance) for each covered fund:

OTHER REVENUES
INVESTMENTS

CDA
(LOCAL)

1. Each investment option shall be reviewed to ensure understanding of the suitability of the investment to the financial requirements of the District;
2. Investments shall be selected that provide preservation and safety of invested funds;
3. Investment strategies for all covered funds shall have as their objective sufficient investment liquidity to timely meet obligations. Maturities longer than one year are authorized provided legal limits are not exceeded;
4. The investment shall be marketable if the need arises to liquidate invested funds before maturity;
5. The investment type shall be consistent with the Board's desired diversification of the investment portfolio; and
6. All invested funds of the District shall attain a rate of return commensurate with the District's investment risk constraints and the cash flow characteristics of the portfolio.

The District shall diversify its investments in all funds by security type and institution. The District shall consider purchase of high quality short-term to medium-term securities that will complement each other in a laddered or liability-matching portfolio structure.

Prudence

Investments shall be made with judgment and care—under circumstances then prevailing which persons of prudence, discretion and intelligence exercise in the management of their own affairs, not for speculation, but for investment, considering the probable safety of their capital as well as the probable income to be derived.

The standard of prudence to be used by investment officials shall be the “prudent person” standard and shall be applied in the context of managing an overall portfolio. Investment officers acting in accordance with written procedures and the investment policy and exercising due diligence shall be relieved of personal responsibility for an individual security’s credit risk or market price changes, provided deviations from expectations are reported in a timely fashion and appropriate action is taken to control adverse developments.

In determining whether an investment official has exercised prudence with respect to an investment decision, the determination shall be made taking into consideration the investment of all funds over which the official had responsibility rather than consideration as to the prudence of a single investment and, whether the investment decision was consistent with the District’s investment policy and written investment procedures.

DATE ISSUED:
11/21/2017 ~~9/25/2012~~
UPDATE 109 ~~LDU-2012-05~~
CDA(LOCAL)-X

ADOPTED:

4 of 15

**Ethics and Conflicts
of Interest**

Officers and employees involved in the investment process shall refrain from personal business activity that could conflict with proper execution of the investment program, or which could impair their ability to make impartial investment decisions.

Officers and employees involved in the investment process shall sign annual statements agreeing to abide by this section of the investment policy and affirming no known conflicts of interest.

An officer or employee involved in the investment process has a personal business relationship with a business organization if:

1. The officer or employee owns ten percent or more of the voting stock or shares of the business organization or owns \$5,000 or more of the fair market value of the business organization;
2. Funds received by the officer or employee from the business organization exceed ten percent of his/her gross income for the previous year;
3. The officer or employee has acquired from the business organization during the previous year investments with a book value of \$2,500 or more for his/her personal account; or
4. The officer is related within the second degree by affinity or consanguinity, as determined under Chapter 573 of the Texas Government Code, to an individual seeking to transact investment business with the entity.

If the investment officer has a personal business relationship with a business organization, a disclosure statement must be filed with the Texas Ethics Commission.

**Authorized
Investments**

From those investments authorized by law and described in CDA(LEGAL), the Board shall permit investment of District funds in the following investment types only, consistent with the strategies and maturities defined in this policy:

1. Obligations of the United States or its agencies and instrumentalities; direct obligations of the state of Texas or its agencies; other obligations, the principal and interest of which are unconditionally guaranteed or insured by, or backed by the full faith and credit of the state of Texas, the United States, or its instrumentalities; including obligations that are fully guaranteed or insured by the Federal Deposit Insurance Corporation (FDIC) or by the explicit full faith and credit of the United States; obligations of states, agencies, counties, cities, and other political subdivisions of any state rated as to in-

vestment quality by a nationally recognized investment rating firm not less than A or its equivalent. *Gov't Code 2256.009*

2. Certificates of deposit or share certificates issued by a depository institution that has its main office or a branch office in Texas that is guaranteed or insured by the FDIC or its successor or the National Credit Union Share Insurance Fund or its successor and is secured by obligations described in item 1 above, including mortgage-backed securities directly issued by a federal agency or instrumentality that have a market value of not less than the principal amount of the certificates or are secured in any other manner and amount provided by law for the deposits of the investment entity. *Gov't Code 2256.010*

In addition to the authority to invest funds in certificates of deposit under the previous section, an investment in certificates of deposit made in accordance with the following conditions is an authorized investment under Government Code 2256.010:

- a. The funds are invested by the District through a broker that has its main office or a branch office in this state and is selected from a list adopted by the District as required by Government Code 2256.025, or a depository institution that has its main office or a branch office in this state and that is selected by the District;
- b. The broker or depository institution selected by the District arranges for the deposit of the funds in certificates of deposit in one or more federally insured depository institutions, wherever located, for the account of the District;
- c. The full amount of the principal and accrued interest of each of the certificates of deposit is insured by the United States or an instrumentality of the United States; and
- d. The District appoints the depository institution selected by the District, an entity described by Government Code 2257.041(d), or a clearing broker-dealer registered with the Securities and Exchange Commission and operating pursuant to Securities and Exchange Commission Rule 15c3-3 (17 C.F.R. Section 240.15c3-3) as custodian for the District with respect to the certificates of deposit issued for the account of the District entity.

Gov't Code 2256.010(b)

3. Fully collateralized repurchase agreements that have a defined termination date, are secured by a combination of cash and obligations of the United States or its agencies and in-

strumentalities, require the securities being purchased by the District or cash held by the District to be pledged to the District, held in the District's name, and deposited with a third party selected and approved by the investment committee, and placed through a primary government securities dealer, as defined by the Federal Reserve or a financial institution doing business in the State of Texas. *Gov't Code 2256.011*

The District shall have a master repurchase agreement signed with the bank or dealer with whom all repurchase agreements are traded.

4. Commercial paper that has a stated maturity of 270 days or fewer from the date of issuance and is rated not less than A1-1 or P-1 or an equivalent rating by at least two nationally recognized credit rating agencies or by one nationally recognized credit rating agency provided the commercial paper is fully secured by an irrevocable letter of credit issued by a bank or organized and existing under U.S. law or the law of any state; and to the extent that commercial paper is held through an investment pool and not as an individual issue through the District. *Gov't Code 2256.013.*
5. No-load money market mutual funds that are regulated by the Securities and Exchange Commission, and have a dollar-weighted average stated maturity of 90 days or fewer, are invested exclusively in obligations described by items 1–4 above, and include in their investment objectives the maintenance of a stable net asset value of \$1 for each share. Investments in mutual funds shall be limited to the percentages authorized by Government Code 2256.014(c). *Gov't Code 2256.014.*
6. A public funds investment pool meeting the requirements of Government Code 2256.016, are rated no lower than AAA or an equivalent rating by at least one nationally recognized rating service, and are authorized by resolution or ordinance by the Board. In addition, a local government investment pool created to function as a money market mutual fund must mark its portfolio to the market daily and, to the extent reasonably possible, stabilize at \$1 net asset value. *Gov't Code 2256.016.*
7. Guaranteed investment contracts that have a defined termination date and are secured by obligations described by Government Code 2256.09(a)(1), excluding those obligations described by Government Code 2256.09(b), in an amount at least equal to the amount of bond proceeds invested under

the contract; such obligations must be pledged to the District and held in the District's name with an approved third party. *Gov't Code 2256.015.*

Corporate bonds are not an eligible investment for a public funds investment pool. *Gov't Code 2256.0204(g)*

**Sellers of
Investments**

**Authorized Brokers/
Dealers**

The investment officers will maintain a list of financial institutions, approved by the investment committee, who are authorized to provide investment services. Prior to handling investments on behalf of the District, a broker/dealer or a qualified representative of a business organization must submit required written documents in accordance with law. [See Sellers of Investments, CDA(LEGAL)]~~In addition, a list will also be maintained of approved security brokers/dealers selected by credit worthiness who are authorized to provide investment services in the state of Texas. These may include primary dealers or regional dealers that qualify under Securities and Exchange Commission Rule 15C3-1 (uniform net capital rule).~~

Representatives of ~~All financial institutions and~~ brokers/dealers shall be registered ~~who desire to become qualified bidders for investment transactions must supply the investment officers with the~~ Texas State Securities Board and must have membership in the Securities Investor Protection Corporation (SIPC), and be in good standing with the following:

- ~~1. Audited financial statements~~
- ~~2.8. Proof of Financial Industry Regulatory Authority (FINRA) certification~~
- ~~3. Trading resolution~~
- ~~4. Proof of registration in the state of Texas~~
- ~~5. Completed broker/dealer questionnaire~~
- ~~6. Certification of having read the District's investment policy~~

~~This information will be reviewed by the investment officers and a recommendation for addition to the list of approved bidders will be submitted to the investment committee for approval.~~

A periodic review, at least annually, of the financial condition and registration of new qualified bidders will be conducted by the investment committee. Recommendations will be provided for consideration by the Board as necessary.

**Monitoring Market
Prices**

The investment officers shall keep the Board informed of significant declines in the market value of the District's investment portfolio. Information sources may include financial/investment publications and electronic media, available software for tracking investments, commercial or investment banks, financial advisors, and representatives/advisors of investment pools or money market funds. Monitoring shall be done monthly or more often as economic conditions warrant by using appropriate reports, indices, or benchmarks for the type of investment.

**Monitoring Rating
Changes**

In accordance with Government Code 2256.005(b), the investment officers shall develop a procedure to monitor changes in investment ratings and to liquidate investments that do not maintain satisfactory ratings.

**Selection of
Depository**

The Board shall select and designate a depository institution in accordance with CDA(LEGAL) ~~and (LOCAL)~~. The depository shall be selected based upon its solvency and stability of leadership as well as on the services provided. The depository shall be selected through a formalized bidding process in response to the District's request for bid (RFB) outlining all services required. Such services should provide the greatest flexibility for money management and should include online account management, positive pay accounts, purchasing card capabilities, and other services considered necessary by District management.

The District shall have the discretion to determine the time span for rebidding the depository contract; however, a three-year period will be the maximum length of time between bidding.

Competitive Bidding

It is the strategy of the District to require competitive bidding for all individual security purchases and sales except for:

1. Transactions with money market mutual funds and local government investment pools (which are deemed to be made at prevailing market rates);
2. Treasury and agency securities purchased at issue through an approved broker/dealer or financial institution; or
3. Automatic overnight "sweep" transactions with the District Depository.

At least three bids or offers must be solicited for all other transactions involving individual securities. The District's investment advisor is also required to solicit at least three bids or offers when transacting trades on the District's behalf. In situations where other dealers do not offer the exact security being offered, offers on the

closest comparable investment may be used to establish a fair market price for the security.

Collateral

The investment officers shall ensure that all District funds (principal and accrued interest) are fully collateralized to 110 percent or insured in one or more of the following manners:

1. FDIC insurance coverage; and/or
2. 110 percent of the uninsured value in obligations of the United States or its agencies or instrumentalities or other authorized securities as outlined in item 4 below.
3. All pledged securities shall be held in safekeeping by the District, in a custodial account approved by the District in a third party financial institution, or with a Federal Reserve Bank. The third party custodian shall be required to issue safekeeping receipts directly to the District and to provide a monthly listing of each specific security, rate, description, maturity, CUSIP number, and other information as may be deemed necessary and appropriate by the District. In order to anticipate market changes and provide a level of additional security for all funds, the collateralization level required shall be 110 percent of the market value. The bank shall be liable for pricing securities and providing 110 percent collateralization.
4. Pledged securities shall be limited to only those items which are specifically permitted as approved investment instruments within the definitions of this policy. Should a pledged security fail to meet this requirement, it shall be the sole responsibility of the financial institution to immediately, without notice from the District or cost to the District, replace any such nonconforming security.

Safekeeping and Custody

Safekeeping and custody of securities and collateral shall be in accordance with state law. It shall be the District's intent to place securities and collateral in the possession of a third party custodian designated by the District where feasible, and held in the District's name as evidenced by safekeeping receipts of the institution with which the securities are deposited.

All investment transactions except investment pool funds and mutual funds will be executed by delivery vs. payment (DVP) to ensure that securities are deposited in an eligible financial institution prior to the release of funds. That is, funds shall not be wired or paid until verification has been made that the Trustee received the securities or collateral.

Diversification

DATE ISSUED:
11/21/2017 ~~9/25/2012~~
UPDATE 109 ~~LDU-2012-05~~
CDA(LOCAL)-X

ADOPTED:

10 of 15

The District shall diversify its investments by security type and institution. The asset mix of the District's portfolio is expressed in terms of maximum commitment so as to allow sufficient flexibility to take advantage of market considerations within the context of this policy. The asset mix requirements are as follows:

Money Market Accounts	60% (maximum)
Certificates of Deposit	25% (maximum)
U.S. Treasury Obligations	100% (maximum)
U.S. Government Securities	100% (maximum)
Repurchase Agreements	15% (maximum)
Public Funds Investment Pools	100% (maximum)

OTHER REVENUES
INVESTMENTS

CDA
(LOCAL)

Commercial Paper	25% (maximum)
Guaranteed Investment Contracts	60% (maximum)

Maximum Maturity

To the extent possible, the District shall attempt to match its investments with anticipated cash flow requirements. Unless matched to a specific cash flow, the District shall not directly invest in securities maturing more than 36 months from the date of purchase. However, securities with a maturity of greater than 12 months shall not exceed ten percent of the total portfolio, and shall be approved by the Board before purchase.

Bond proceeds and debt service funds may be invested in securities exceeding 12 months if the maturity of such investments is made to coincide as nearly as practicable with the expected use of the funds.

Arbitrage

The Tax Reform Act of 1986 provided limitations restricting the amount of income that could be generated from the investment of tax-exempt General Obligation Bond proceeds and debt service income. The arbitrage rebate provisions require that the District compute earnings on investment from each issue of bonds on an annual basis to determine if a rebate is required. To determine the District's arbitrage position, the District is required to perform specific calculations relative to the actual yield earned on the investment of the funds and the yield that could have been earned if the funds had been invested at a rate equal to the yield on the bonds sold by the District. The rebate provision states that periodically (not less than once every five years, and not later than 60 days after the maturity of the bonds), the District is required to pay the U.S. Treasury a rebate of excess earnings based on the District being in a positive arbitrage position. The Tax Reform restrictions require precision in the monitoring and recording of investments as a whole, and particularly as relates to yields and computations so as to ensure compliance. Failure to comply can dictate that the bonds become taxable, retroactively from the date of issue.

The District's investment position relative to arbitrage is the continued pursuit of maximizing the yield on applicable investments while ensuring the safety of capital and liquidity. It is a fiscally sound position to continue maximization of yield and rebate excess earnings, if necessary.

Benchmark

The District's investment strategy is a passive one, in that the majority of securities shall be purchased and held to maturity. Additionally, cash inflows and outflows shall be monitored daily. Given this strategy, the basis used by the investment officers to determine

whether market yields are being achieved shall be the Two-Year U.S. Treasury Bill and the average Fed Funds rate.

Internal Control

The investment portfolio, as well as compliance with this policy, shall be reviewed quarterly by the investment committee and annually by the District's external auditor in conjunction with the annual audit of the District's financial statements.

Investment Committee

The investment committee shall review the investment strategies annually and make recommendations for revision as necessary. The investment committee includes, but is not limited to, the Superintendent, the chief financial officer, the director of finance, the budget and treasury officer, the financial advisor, Board financial audit committee (nonvoting), and up to two investment bankers.

Quality of Investment Management

Designated investment officers of the District shall participate in periodic training through courses and seminars offered by professional organizations, associations, and other independent sources approved by the investment committee to ensure the quality and capability of investment management in compliance with the Public Funds Investment Act.

Investment Training

Within 12 months after taking office or assuming duties, designated investment officers of the District shall attend at least one training session from an independent source approved either by the Board or by the investment committee advising the investment officers. This initial training must contain at least ten hours of instruction relating to their respective responsibilities under the Public Funds Investment Act. *Gov't Code 2256.008(a)*

The investment officers must also attend an investment training session not less than once in a two-year period that begins on the first day of the District's fiscal year and consists of the two consecutive fiscal years after that date, and receive not less than ten hours of instruction relating to investment responsibilities under the Public Funds Investment Act from an independent source approved by the Board or the investment committee advising the investment officers. If the District has contracted with another investing entity to invest the District's funds, this training requirement may be satisfied by having a Board officer attend four hours of appropriate instruction in a two-year period that begins on the first day of the District's fiscal year and consists of the two consecutive fiscal years after that date. *Gov't Code 2256.008(a), (b)*

Investment training shall include education in investment controls, security risks, strategy risks, market risks, diversification of investment portfolio, and compliance with the Government Code, Chapter 2256. *Gov't Code 2256.008(c)*

Reporting

Investment performance shall be regularly monitored by investment staff and reported to the Board. Month-end market prices on each security will be obtained by the Budget and Treasury Officer from a variety of nationally recognized securities databases (e.g., the Wall Street Journal, Bloomberg, etc.). These prices will be recorded in the District's portfolio database and included in all management reports where necessary as well as the District's Comprehensive Annual Financial Report.

Not less than quarterly the investment officers will submit to the Board a written report of the status of the current investment portfolio. The report must meet the requirements of Chapter 2256 of the Government Code (Public Funds Investment Act) and:

1. Describe in detail the investment position of the District on the date of the report;
2. Be prepared jointly by all investment officers of the District;
3. Be signed by each investment officer of the District;
4. Contain a summary statement for each pooled fund group that states the beginning market value for the period and the ending market value for the period;
5. State the book value and market value of each separately invested asset at the end of the reporting period by the type of asset and type of fund, and type of institution;
6. Percent of portfolio by type of asset, fund, and institution will be provided;
7. State the maturity date of each separately invested asset that has a maturity date;
8. State the account or fund or pooled fund group for which each individual investment was acquired; and
9. State the compliance of the investment portfolio as it relates to the investment strategy and relevant provisions of this policy and the Public Funds Investment Act.

An independent auditor shall formally review the quarterly reports prepared under this section at least annually, and that auditor shall report the results of the review to the Board.

**Annual
Compliance
Audit**

In conjunction with the annual financial audit, a compliance audit shall be performed that includes an audit of management controls on investments and adherence to the District's established policy.

Lamar CISD
079901

OTHER REVENUES
INVESTMENTS

CDA
(LOCAL)

**Investment Policy
Approval**

The District's investment policy shall be adopted by resolution of the Board. The policy shall be reviewed annually and approved by the Board.

DATE ISSUED:
11/21/2017 ~~9/25/2012~~
UPDATE 109 ~~LDU-2012.05~~
CDA(LOCAL)-X

ADOPTED: ~~ADOPTED:~~

15 of 15

**SAFETY PROGRAM/RISK MANAGEMENT
EMERGENCY PLANS**

**CKC
(LOCAL)**

**EMERGENCY
OPERATIONS PLAN**

The Superintendent shall ensure updating of the District's Emergency Operations Plan and ongoing staff training.

REVISED

Lamar CISD
079901

SAFETY PROGRAM/RISK MANAGEMENT
EMERGENCY PLANS

CKC
(LOCAL)

**Emergency
Operations Plan**

The Superintendent shall ensure updating of the District's Emergency Operations Plan and ongoing staff training.

As required by law, the emergency operations plan shall include the District's procedures addressing reasonable security measures when District property is used as a polling place.

DATE ISSUED: 11/21/2017~~6/7/2006~~
UPDATE 10978
CKC(LOCAL)-A

ADOPTED:

1 of 1

TRANSPORTATION MANAGEMENT
STUDENT TRANSPORTATION

CNA
(LOCAL)

ELIGIBILITY

The District shall permit students for whom the District does not receive state transportation funds to use District transportation, in accordance with time and space limitations and administrative regulations.

Applicable fees, if any, shall be approved by the Board and published in administrative regulations.

HAZARDOUS
CONDITIONS

The Board shall annually adopt a resolution to identify hazardous conditions within two miles of a school campus. The resolution shall describe the specific hazardous areas in which reside students who would otherwise be ineligible for transportation, but for whom the District shall provide transportation because of the hazardous conditions in those areas.

The District shall publish the locations of the routes with hazardous conditions.

**Hazardous Traffic
Conditions and
High-Risk Areas
Eligibility**

~~The District shall permit students for whom~~ the District applies for the additional ~~does not receive state~~ transportation allotment provided by the state for students who live within two miles of a school campus, the Board shall ~~funds to use District transportation, in accordance with time and space limitations and administrative regulations.~~

~~Applicable fees, if any, shall be approved by the Board and published in administrative regulations.~~

**Hazardous
Conditions**

~~The Board shall annually~~ adopt a resolution to identify hazardous traffic conditions or areas presenting a high risk of violence within two miles of ~~the~~a school campus. The resolution shall ~~include~~~~describe~~ the specific hazardous or high-risk areas in which transportation shall be provided, and ~~the~~reside students who would otherwise be ineligible for transportation, but for whom the District shall provide transportation because of the hazardous conditions in these areas.

~~The~~ District shall publish the locations of ~~these~~the routes. The Board shall adopt a revised resolution when necessary to accurately reflect changes to the conditions or areas ~~with hazardous conditions.~~

The Superintendent shall develop regulations regarding the use of a prepaid meal card or account to purchase meals served at school. The regulations shall address:

1. The length of the grace period during which a student may continue to purchase meals with a meal card or account that is exhausted or insufficient; and
2. Parent notification in the event of an exhausted card or account, including a schedule for repayment.

No fees or interest shall be charged in connection with meals purchased with an exhausted card or account.

Food Donations

The Superintendent shall be authorized to develop regulations for campuses to donate food in accordance with law.

Meal Charges

State Law

As established by ~~regarding~~ the Board, ~~use of~~ a student with an exhausted or insufficient balance on his or her ~~prepaid~~ meal card or meal account shall be allowed to continue to purchase meals for up to a total of \$15 and up to five courtesy meals. The Superintendent shall develop administrative ~~to purchase meals served at school. The~~ regulations for this grace period to ~~shall~~ address:

1. ~~—~~ The District's processes for parent notification ~~length of the grace period~~ during the grace period ~~which a student may continue to purchase meals with a meal card or account that is exhausted or insufficient; and~~
- 2.1. ~~Parent notification in the event of an exhausted card or account, including a schedule for repayment; and-~~
 1. Whether the student will be limited to certain foods or beverages during this grace period, and, if so, the District's efforts to minimize overt identification of the student.

No fees or interest shall be charged by the District for ~~in connection with~~ meals purchased during the grace period.

Federal Law

For each campus that participates in the federal school breakfast-~~with an exhausted card~~ or lunch programs under which students may incur a meal charge, the District's administrative regulations shall also address procedures for a student who has insufficient funds to purchase a meal following exhaustion of the grace period described above. The procedures shall address:

1. The parameters under which reimbursable or alternate meals shall be served to the student;
2. The District's efforts to minimize overt identification of the student; and

How the District will attempt to collect unpaid debt in order to maintain the financial integrity of the food service account.

REQUIRED WORKERS' COMPENSATION COVERAGES
28 TAC 110.110(c)(7), adopted to implement Texas Labor Code 406.096

The District shall use the following language for bid specifications and contracts for building or construction, without any additional words or changes, except those required to accommodate the specific document in which they are contained or to impose stricter standards of documentation.

A copy of a certificate of insurance, a certificate of authority to self-insure issued by the Texas Department of Insurance (TDI), or a coverage agreement (DWC-81, DWC-82, DWC-83, or DWC-84), showing statutory workers' compensation insurance coverage for the person's or entity's employees providing services on a project is required for the duration of the project.

Duration of the project includes the time from the beginning of the work on the project until the contractor's/person's work on the project has been completed and accepted by the governmental entity.

Persons providing services on the project ("subcontractor" in Texas Labor Code 406.096) include all persons or entities performing all or part of the services the contractor has undertaken to perform on the project, regardless of whether that person contracted directly with the contractor and regardless of whether that person has employees. This includes, without limitation, independent contractors, subcontractors, leasing companies, motor carriers, owner-operators, employees of any such entity, or employees of any entity that furnishes persons to provide services on the project.

Services include, without limitation, providing, hauling, or delivering equipment or materials, or providing labor, transportation, or other service related to a project. Services do not include activities unrelated to the project, such as food/beverage vendors, office supply deliveries, and delivery of portable toilets.

The contractor shall provide coverage, based on proper reporting of classification codes and payroll amounts and filing of any coverage agreements, which meets the statutory requirements of Texas Labor Code 401.011(44) for all employees of the contractor providing services on the project for the duration of the project.

The contractor must provide a certificate of coverage to the governmental entity prior to being awarded the contract.

If the coverage period shown on the contractor's current certificate of coverage ends during the duration of the project, the contractor must, prior to the end of the coverage period, file a new certificate of coverage with the governmental entity showing that coverage has been extended.

The contractor shall obtain from each person providing services on a project, and provide to the governmental entity:

1. A certificate of coverage, prior to that person beginning work on the project, so the governmental entity will have on file certificates of coverage showing coverage for all persons providing services on the project; and

FACILITIES CONSTRUCTION

CV
(EXHIBIT)

2. No later than seven days after receipt by the contractor, a new certificate of coverage showing extension of coverage, if the coverage period shown on the current certificate of coverage ends during the duration of the project.

The contractor shall retain all required certificates of coverage for the duration of the project and for one year thereafter.

The contractor shall notify the governmental entity in writing by certified mail or personal delivery, within ten days after the contractor knew or should have known, of any change that materially affects the provision of coverage of any person providing services on the project.

The contractor shall post on each project site a notice, in the text, form, and manner prescribed by the TDI, informing all persons providing services on the project that they are required to be covered, and stating how a person may verify coverage and report lack of coverage.

The contractor shall contractually require each person with whom it contracts to provide services on a project, to:

1. Provide coverage, based on proper reporting of classification codes and payroll amounts and filing of any coverage agreements, which meets the statutory requirements of Texas Labor Code 401.011(44) for all of its employees providing services on the project for the duration of the project;
2. Provide to the contractor, prior to that person beginning work on the project, a certificate of coverage showing that coverage is being provided for all employees of the person providing services on the project for the duration of the project;
3. Provide the contractor, prior to the end of the coverage period, a new certificate of coverage showing extension of coverage, if the coverage period shown on the current certificate of coverage ends during the duration of the project.
4. Obtain from each other person with whom it contracts, and provide to the contractor:
 - a. A certificate of coverage, prior to the other person beginning work on the project; and
 - b. A new certificate of coverage showing extension of coverage, prior to the end of the coverage period, if the coverage period shown on the current certificate of coverage ends during the duration of the project;
5. Retain all required certificates of coverage on file for the duration of the project and for one year thereafter;
6. Notify the governmental entity in writing by certified mail or personal delivery, within ten days after the person knew or should have known, of any change that materially affects the provision of coverage of any person providing services on the project; and
7. Contractually require each person with whom it contracts to perform as required by items 1–6, with the certificates of coverage to be provided to the person for whom they are providing services.

FACILITIES CONSTRUCTION

CV
(EXHIBIT)

By signing this contract or providing or causing to be provided a certificate of coverage, the contractor is representing to the governmental entity that all employees of the contractor who will provide services on the project will be covered by workers' compensation coverage for the duration of the project, that the coverage will be based on proper reporting of classification codes and payroll amounts, and that all coverage agreements will be filed with the appropriate insurance carrier or, in the case of a self-insured, with the TDI's Division of Self-Insurance Regulation. Providing false or misleading information may subject the contractor to administrative penalties, criminal penalties, civil penalties, or other civil actions.

The contractor's failure to comply with any of these provisions is a breach of contract by the contractor that entitles the governmental entity to declare the contract void if the contractor does not remedy the breach within ten days after receipt of notice of breach from the governmental entity.

The coverage requirement recited above does not apply to sole proprietors, partners, and corporate officers who are excluded from coverage in an insurance policy or certificate of authority to self-insure that is delivered, issued for delivery, or renewed on or after January 1, 1996.

28 TAC 110.110(i)

TERMINATION OF EMPLOYMENT

DF
(LOCAL)

**Board's Designee for
Certain Termination
Actions**

The Superintendent shall serve as the Board's designee to suspend a contract employee without pay, provide written notice that the person's contract is void, and terminate employment as soon as practicable when the District:

1. Receives notice that an individual's certificate has been revoked by the State Board for Educator Certification (SBEC) for reasons that require immediate action by the District; or
2. Becomes aware that a contract employee has been convicted of or has received deferred adjudication for a felony offense.

[See also DFAA, DFBA, and DFCA, as appropriate.]

	<p>Each District employee shall perform his or her duties in accordance with state and federal law, District policy, and ethical standards. [See DH(EXHIBIT)]</p> <p>Each District employee shall recognize and respect the rights of students, parents, other employees, and members of the community and shall work cooperatively with others to serve the best interests of the District.</p> <p>An employee wishing to express concern, complaints, or criticism shall do so through appropriate channels. [See DGBA]</p>
VIOLATIONS OF STANDARDS OF CONDUCT	<p>Each employee shall comply with the standards of conduct set out in this policy and with any other policies, regulations, and guidelines that impose duties, requirements, or standards attendant to his or her status as a District employee. Violation of any policies, regulations, or guidelines may result in disciplinary action, including termination of employment. [See DCD and DF series]</p>
WEAPONS PROHIBITED	<p>The District prohibits the use, possession, or display of any firearm, illegal knife, club, or prohibited weapon, as defined at FNCG, on District property at all times.</p>
EXCEPTIONS	<p>No violation of this policy occurs when the use, possession, or display of an otherwise prohibited weapon takes place as part of a District-approved activity supervised by proper authorities. [See FOD]</p>
ELECTRONIC MEDIA	<p>Electronic media includes all forms of social media, such as text messaging, instant messaging, electronic mail (e-mail), web logs (blogs), electronic forums (chat rooms), video-sharing websites, editorial comments posted on the Internet, and social network sites. Electronic media also includes all forms of telecommunication, such as landlines, cell phones, and web-based applications.</p>
USE WITH STUDENTS	<p>In accordance with administrative regulations, a certified or licensed employee, or any other employee designated in writing by the Superintendent or a campus principal, may use electronic media to communicate with currently enrolled students about matters within the scope of the employee's professional responsibilities. All other employees are prohibited from using electronic media to communicate directly with students who are currently enrolled in the District. The regulations shall address:</p> <ol style="list-style-type: none">1. Exceptions for family and social relationships;2. The circumstances under which an employee may use text messaging to communicate with students; and

EMPLOYEE STANDARDS OF CONDUCT

DH
(LOCAL)

3. Other matters deemed appropriate by the Superintendent or designee.

Each employee shall comply with the District's requirements for records retention and destruction to the extent those requirements apply to electronic media. [See CPC]

PERSONAL USE

An employee shall be held to the same professional standards in his or her public use of electronic media as for any other public conduct. If an employee's use of electronic media violates state or federal law or District policy, or interferes with the employee's ability to effectively perform his or her job duties, the employee is subject to disciplinary action, up to and including termination of employment.

SAFETY
REQUIREMENTS

Each employee shall adhere to District safety rules and regulations and shall report unsafe conditions or practices to the appropriate supervisor.

HARASSMENT OR
ABUSE

An employee shall not engage in prohibited harassment, including sexual harassment, of:

1. Other employees. [See DIA]
2. Students. [See FFH; see FFG regarding child abuse and neglect.]

While acting in the course of employment, an employee shall not engage in prohibited harassment, including sexual harassment, of other persons, including Board members, vendors, contractors, volunteers, or parents.

An employee shall report child abuse or neglect as required by law. [See FFG]

RELATIONSHIPS WITH
STUDENTS

An employee shall not form romantic or other inappropriate social relationships with students. Any sexual relationship between a student and a District employee is always prohibited, even if consensual. [See FFH]

TOBACCO AND
E-CIGARETTES

An employee shall not smoke or use tobacco products or e-cigarettes on District property, in District vehicles, or at school-related activities. [See also GKA]

ALCOHOL AND DRUGS

An employee shall not manufacture, distribute, dispense, possess, use, or be under the influence of any of the following substances during working hours while on District property or at school-related activities during or outside of usual working hours:

1. Any controlled substance or dangerous drug as defined by law, including but not limited to marijuana, any narcotic drug,

EMPLOYEE STANDARDS OF CONDUCT

DH
(LOCAL)

hallucinogen, stimulant, depressant, amphetamine, or barbiturate.

2. Alcohol or any alcoholic beverage.
3. Any abusable glue, aerosol paint, or any other chemical substance for inhalation.
4. Any other intoxicant or mood-changing, mind-altering, or behavior-altering drug.

An employee need not be legally intoxicated to be considered "under the influence" of a controlled substance or alcohol.

EXCEPTIONS

It shall not be considered a violation of this policy if the employee:

1. Manufactures, possesses, or dispenses a substance listed above as part of the employee's job responsibilities;
2. Uses or possesses a controlled substance or drug authorized by a licensed physician prescribed for the employee's personal use;
3. Possesses a controlled substance or drug that a licensed physician has prescribed for the employee's child or other individual for whom the employee is a legal guardian; or
4. Consumes an alcoholic beverage served at a school-related activity or event that takes place off District property and at which alcohol may be legally served, so long as the employee does not have specific assigned duties at the event.

NOTICE

Each employee shall be given a copy of the District's notice regarding drug-free schools. [See DI(EXHIBIT)]

A copy of this policy, a purpose of which is to eliminate drug abuse from the workplace, shall be provided to each employee at the beginning of each year or upon employment.

ARRESTS,
INDICTMENTS,
CONVICTIONS, AND
OTHER
ADJUDICATIONS

An employee shall notify his or her principal or immediate supervisor within three calendar days of any arrest, indictment, conviction, no contest or guilty plea, or other adjudication of the employee for any felony, any offense involving moral turpitude, and any of the other offenses as indicated below:

1. Crimes involving school property or funds;
2. Crimes involving attempt by fraudulent or unauthorized means to obtain or alter any certificate or permit that would entitle any person to hold or obtain a position as an educator;

EMPLOYEE STANDARDS OF CONDUCT

DH
(LOCAL)

3. Crimes that occur wholly or in part on school property or at a school-sponsored activity; or
4. Crimes involving moral turpitude, which include:
 - Dishonesty; fraud; deceit; theft; misrepresentation;
 - Deliberate violence;
 - Base, vile, or depraved acts that are intended to arouse or gratify the sexual desire of the actor;
 - Felony possession or conspiracy to possess, or any misdemeanor or felony transfer, sale, distribution, or conspiracy to transfer, sell, or distribute any controlled substance defined in Chapter 481 of the Health and Safety Code;
 - Felony driving while intoxicated (DWI); or
 - Acts constituting abuse or neglect under the Texas Family Code.

DRESS AND
GROOMING

An employee's dress and grooming shall be clean, neat, in a manner appropriate for his or her assignment, and in accordance with any additional standards established by his or her supervisor and approved by the Superintendent.

Each District employee shall perform his or her duties in accordance with state and federal law, District policy, and ethical standards. ~~The District holds all employees accountable to the Educators' Code of Ethics.~~ [See DH(EXHIBIT)]

Each District employee shall recognize and respect the rights of students, parents, other employees, and members of the community and shall work cooperatively with others to serve the best interests of the District.

An employee wishing to express concern, complaints, or criticism shall do so through appropriate channels. [See DGBA]

Violations of Standards of Conduct

Each employee shall comply with the standards of conduct set out in this policy and with any other policies, regulations, and guidelines that impose duties, requirements, or standards attendant to his or her status as a District employee. Violation of any policies, regulations, or guidelines may result in disciplinary action, including termination of employment. [See DCD and DF series]

Weapons Prohibited

The District prohibits the use, possession, or display of any firearm, ~~location-restricted~~ illegal knife, club, or prohibited weapon, as defined at FNCG, on District property at all times.

Exceptions

No violation of this policy occurs when:

1. A District employee who holds a Texas handgun license stores a handgun or other firearm in a locked vehicle in a parking lot, parking garage, or other parking area provided by the District, provided the handgun or other firearm is not loaded and not in plain view; or

~~The~~ the use, possession, or display of an otherwise prohibited weapon takes place as part of a District-approved activity supervised by proper authorities. [See FOD]

Electronic Communication Media

~~Electronic media includes all forms of social media, such as text messaging, instant messaging, electronic mail (e-mail), web logs (blogs), electronic forums (chat rooms), video sharing websites, editorial comments posted on the Internet, and social network sites. Electronic media also includes all forms of telecommunication, such as landlines, cell phones, and web-based applications.~~

Use with Students

~~In accordance with administrative regulations, a~~ certified employee, ~~or~~ licensed employee, or any other employee designated in writing by the Superintendent or a campus principal, may use electronic communication, as this term is defined by law, ~~media to communicate~~ with currently enrolled students ~~only~~ about matters within the scope of the employee's professional responsibilities. ~~All other~~

~~employees are prohibited from using electronic media to communicate directly with students who are currently enrolled in the District. The regulations shall address:~~

Unless an exception has been made in accordance with the employee handbook or other administrative regulations, an employee shall not use a personal electronic communication platform, application, or account to communicate with currently enrolled students.

Unless authorized above, all other employees are prohibited from using electronic communication directly with students who are currently enrolled in the District. The employee handbook or other administrative regulations shall further detail:

1. Exceptions for family and social relationships;
2. The circumstances under which an employee may use text messaging to communicate with individual students or student groups; ~~and~~
2. Hours of the day during which electronic communication is discouraged or prohibited; and
3. Other matters deemed appropriate by the Superintendent or designee.

In accordance with ethical standards applicable to all District employees [see DH(EXHIBIT)], an employee shall be prohibited from using electronic communications in a manner that constitutes prohibited harassment or abuse of a District student; adversely affects the student's learning, mental health, or safety; includes threats of violence against the student; reveals confidential information about the student; or constitutes an inappropriate communication with a student, as described in the Educators' Code of Ethics.

An employee shall have no expectation of privacy in electronic communications with students. Each employee shall comply with the District's requirements for records retention and destruction to the extent those requirements apply to electronic communication. ~~media.~~ [See CPC]

Personal Use

All employees ~~An employee~~ shall be held to the same professional standards in ~~their~~ ~~his or her~~ public use of electronic communication ~~media~~ as for any other public conduct. If an employee's use of electronic communication ~~media~~ violates state or federal law or District policy, or interferes with the employee's ability to effectively perform his or her job duties, the employee is subject to disciplinary action, up to and including termination of employment.

EMPLOYEE STANDARDS OF CONDUCT

DH
(LOCAL)

Reporting Improper Communication	In accordance with administrative regulations, an employee shall notify his or her supervisor when a student engages in improper electronic communication with the employee.
Disclosing Personal Information	An employee shall not be required to disclose his or her personal e-mail address or personal phone number to a student.
Safety Requirements	Each employee shall adhere to District safety rules and regulations and shall report unsafe conditions or practices to the appropriate supervisor.
Harassment or Abuse	<p>An employee shall not engage in prohibited harassment, including sexual harassment, of:</p> <ul style="list-style-type: none">1.4. Other employees. [See DIA]2.5. Students. [See FFH; see FFG regarding child abuse and neglect.] <p>While acting in the course of employment, an employee shall not engage in prohibited harassment, including sexual harassment, of other persons, including Board members, vendors, contractors, volunteers, or parents.</p> <p>An employee shall report child abuse or neglect as required by law. [See FFG]</p>
Relationships with Students	<p>An employee shall not form romantic or other inappropriate social relationships with students. Any sexual relationship between a student and a District employee is always prohibited, even if consensual. [See FFH]</p> <p>As required by law, the District shall notify the parent of a student with whom an educator is alleged to have engaged in certain misconduct. [See FFF]</p>
Tobacco and E-Cigarettes	An employee shall not smoke or use tobacco products or e-cigarettes on District property, in District vehicles, or at school-related activities. [See also GKA]
Alcohol and Drugs / Notice of Drug-Free Workplace	<p>As a condition of employment, an employee shall abide by the terms of the following drug-free workplace provisions. An employee shall notify the Superintendent in writing if the employee is convicted for a violation of a criminal drug statute occurring in the workplace in accordance with Arrests, Indictments, Convictions, and Other Adjudications, below.</p> <p>An employee shall not manufacture, distribute, dispense, possess, use, or be under the influence of any of the following substances during working hours while on District property or at school-related activities during or outside of usual working hours::</p>

EMPLOYEE STANDARDS OF CONDUCT

DH
(LOCAL)

- ~~4.6.~~ Any controlled substance or dangerous drug as defined by law, including but not limited to marijuana, any narcotic drug, hallucinogen, stimulant, depressant, amphetamine, or barbiturate.
- ~~2.7.~~ Alcohol or any alcoholic beverage.
- ~~3.8.~~ Any abusable glue, aerosol paint, or any other chemical substance for inhalation.
- ~~4.9.~~ Any other intoxicant or mood-changing, mind-altering, or behavior-altering drug.

An employee need not be legally intoxicated to be considered "under the influence" of a controlled substance or alcohol.

Exceptions

It shall not be considered a violation of this policy if the employee:

- ~~4.10.~~ Manufactures, possesses, or dispenses a substance listed above as part of the employee's job responsibilities;
- ~~2.11.~~ Uses or possesses a controlled substance or drug authorized by a licensed physician prescribed for the employee's personal use; or
- ~~3.12.~~ Possesses a controlled substance or drug that a licensed physician has prescribed for the employee's child or other individual for whom the employee is a legal guardian. ~~or~~
- ~~4.13.~~ Consumes an alcoholic beverage served at a school-related activity or event that takes place off District property and at which alcohol may be legally served, so long as the employee does not have specific assigned duties at the event.

Sanctions
Notice

~~Each employee who violates these shall be given a copy of the District's notice regarding drug-free schools. [See D(EXHIBIT)]~~

~~A copy of this policy, a purpose of which is to eliminate drug abuse from the workplace provisions, shall be subject provided to disciplinary sanctions. Sanctions may include: each employee at the beginning of each year or upon employment.~~

1. Referral to drug and alcohol counseling or rehabilitation programs;
2. Referral to employee assistance programs;
3. Termination from employment with the District; and
4. Referral to appropriate law enforcement officials for prosecution.

EMPLOYEE STANDARDS OF CONDUCT

DH
(LOCAL)

Notice

Employees shall receive a copy of this policy.

**Arrests, Indictments,
Convictions, and
Other Adjudications**

An employee shall notify his or her principal or immediate supervisor within three calendar days of any arrest, indictment, conviction, no contest or guilty plea, or other adjudication of the employee for any felony, any offense involving moral turpitude, and any of the other offenses as indicated below:

~~4~~.14. Crimes involving school property or funds;

~~2~~.15. Crimes involving attempt by fraudulent or unauthorized means to obtain or alter any certificate or permit that would entitle any person to hold or obtain a position as an educator;

~~3~~.16. Crimes that occur wholly or in part on school property or at a school-sponsored activity; or

~~4~~.17. Crimes involving moral turpitude, which include:

- Dishonesty; fraud; deceit; theft; misrepresentation;
- Deliberate violence;
- Base, vile, or depraved acts that are intended to arouse or gratify the sexual desire of the actor;
- Felony possession or conspiracy to possess, or any misdemeanor or felony transfer, sale, distribution, or conspiracy to transfer, sell, or distribute any controlled substance defined in Chapter 481 of the Health and Safety Code;
- Felony driving while intoxicated (DWI); or
- Acts constituting abuse or neglect under the Texas Family Code.

Dress and Grooming

An employee's dress and grooming shall be clean, neat, in a manner appropriate for his or her assignment, and in accordance with any additional standards established by his or her supervisor and approved by the Superintendent.

DRUG-FREE WORKPLACE NOTICE

The District prohibits the unlawful manufacture, distribution, dispensation, possession, or use of controlled substances, illegal drugs, inhalants, and alcohol in the workplace.

Employees who violate this prohibition shall be subject to disciplinary sanctions. Sanctions may include:

- Referral to drug and alcohol counseling or rehabilitation programs;
- Referral to employee assistance programs;
- Termination from employment with the District; and
- Referral to appropriate law enforcement officials for prosecution.

As a condition of employment, an employee shall:

- Abide by the terms of this notice; and
- Notify the Superintendent, in writing, if the employee is convicted for a violation of a criminal drug statute occurring in the workplace. The employee must provide the notice in accordance with DH(LOCAL).

[This notice complies with the requirements of the federal Drug-Free Workplace Act (41 U.S.C. 702).]

Note: Unless otherwise noted, the terms “video recording,” “video surveillance,” and “video monitoring” shall also include any associated audio recordings.

REQUESTS AND
NOTICE

The District shall comply with requests for video and audio monitoring of certain self-contained special education classrooms and settings as required by law to promote student safety in those settings. Regular or continual monitoring of video recordings shall be prohibited. Video recordings shall not be used for teacher evaluation or monitoring or for any purpose other than the promotion of student safety.

A parent, Trustee, or staff member making a request for video surveillance under this policy shall submit the request to the campus principal or the director of special programs on a form provided by the District, and the principal or the director of special programs shall provide a response to the requestor within ten District business days. The principal shall provide advance written notice to staff on the campus and to parents of the students assigned to the classroom or setting that video and audio surveillance will be conducted in the classroom or setting. The Superintendent shall develop administrative regulations as necessary to implement these request, response, and notice provisions.

INSTALLATION AND
OPERATION

When the District has installed video cameras in a classroom or other setting as required by law, the District shall operate the cameras during the instructional day at all times when students are in the classroom or other setting. For purposes of this policy, the instructional day shall be defined as the portion of a school day during which instruction is taking place in the classroom or other setting.

A campus shall continue to operate and maintain any video cameras placed in the classroom or other setting for as long as the classroom or other setting continues to satisfy the requirements in Education Code 29.022(a).

Video cameras must be capable of recording video and audio of all areas of the classroom or setting, except that no video surveillance shall be conducted of the inside of a bathroom or other area used for toileting or diapering a student or removing or changing a student's clothes.

The District may post notice at the entrance to a classroom or other setting in which video cameras are placed stating that video and audio surveillance is conducted in that classroom or setting.

SPECIAL EDUCATION
VIDEO/AUDIO MONITORING

EHBAF
(LOCAL)

RETENTION OF
RECORDINGS

Video recordings shall be retained for at least six months after the date of the recording but may be retained for a longer period in accordance with the District's records management program or as required by law. [See CPC]

CONFIDENTIALITY OF
RECORDINGS

Video recordings made in accordance with this policy shall be confidential and shall only be accessed or viewed by the individuals and in the limited circumstances permitted by law. Contractors and District personnel with job duties related to the installation, operation, or maintenance of video equipment, or the retention of video recordings, who incidentally view recordings when performing regular job duties such as ensuring the proper functioning of the equipment or pulling specific footage shall not be considered in violation of the confidentiality provisions.

The following individuals shall have authority to view video recordings to the extent permitted by the Family Educational Rights and Privacy Act (FERPA):

1. A District employee or a parent of a student who is involved in an incident documented by a recording for which a complaint has been reported to the District;
2. Appropriate Department of Family and Protective Services (DFPS) personnel as part of an investigation of alleged abuse or neglect of a child;
3. A peace officer, school nurse, District administrator trained in de-escalation and restraint techniques, or human resource staff member in response to a complaint or an investigation of an incident; and
4. Appropriate TEA or State Board for Educator Certification personnel or their agents as part of an investigation.

For purposes of this policy, the term "human resource staff member" shall include the Superintendent, a principal, an assistant principal or other campus administrator, and any supervisory position within the District's human resources office. If an individual listed in items 2 through 4 above believes that a recording shows a violation of District policy or campus procedures, the individual may allow access to the recording by appropriate legal and human resources personnel designated by the District for the purpose of determining whether a policy or procedure has been violated.

Any person who suspects that child abuse or neglect has occurred shall report this suspicion as required by law and District policy. [See FFG]

SPECIAL EDUCATION
VIDEO/AUDIO MONITORING

EHBAF
(LOCAL)

REPORTING AN
INCIDENT

A person alleging that an incident, as defined by law, has occurred in a classroom or other setting in which video surveillance is conducted shall file a report on the form provided by the District with the principal as soon as possible after the person suspects the alleged incident. If possible, an incident report form shall be filed within 48 hours of the facts giving rise to the allegation. The principal shall promptly view, or direct an authorized individual to view, the video surveillance footage to identify the relevant portion of the recording. No later than ten District business days after the report is filed, the principal or designee shall respond by notifying the person whether the alleged incident was recorded in the District's video surveillance footage and shall initiate other steps as required by law, District policy, or local procedures.

COMPLAINTS

Complaints related to video and audio recordings under this policy shall be filed in accordance with DGBA, FNG, or GF, as applicable.

Note: Unless otherwise noted, the terms “video recording,” “video surveillance,” and “video monitoring” shall also include any associated audio recordings. In addition, the term “classroom” shall also include other special education settings subject to video and audio recording required by law.

To promote student safety, ~~the~~ The District shall comply with requests for video and audio monitoring of certain self-contained special education classrooms ~~and settings as required by law to promote student safety in those settings.~~ Regular or continual monitoring of video recordings shall be prohibited. Video recordings shall not be used for teacher evaluation or monitoring or for any purpose other than the promotion of student safety.

The Superintendent is responsible for coordinating the provision of equipment to campuses in compliance with the law.

The Superintendent shall ensure that administrative regulations are developed to implement this policy.

Requests

For Following Year
A parent of a student receiving special education services and whose placement for the following school year will be in a self-contained classroom eligible Notice

~~A parent, Trustee, or staff member making a request~~ for video surveillance may request that a video camera be placed in the classroom by the end of the current school year or by the tenth business day after the student’s admission, review, and dismissal (ARD) committee determines the student’s placement, whichever is later. If such a ~~under this policy shall submit the~~ request is made, ~~to~~ the campus shall begin operation of the camera by the deadlines in law.

Written requests from a parent, assistant principal, principal, staff member, or the Board shall be submitted and processed in accordance with the procedures in law.

Response

As required by law, ~~the director of special programs on a form provided by the~~ District, ~~and the principal or the director of special programs~~ shall provide a response to the requestor not later than the seventh business day after receipt of the request.

Notice

Before a camera is activated, ~~the~~ ~~within ten District business days.~~ The principal shall provide advance written notice to staff on the campus and to parents of the students assigned to ~~or engaging in school activities in the classroom or setting~~ that video and audio surveillance will be conducted in the classroom ~~or setting.~~ ~~The Superintendent shall develop administrative regulations as necessary to implement these request, response, and notice provisions.~~

**Installation and
Operation**

The classroom subject to the request shall begin operation of video surveillance not later than the time frames required in law, except when the District is granted an extension of time.

When the District has installed video cameras in a classroom ~~or other setting~~ as required by law, the District shall operate the cameras during the instructional day at all times when students are in the classroom. ~~or other setting~~. For purposes of this policy, the instructional day shall be defined as the portion of a school day during which instruction is taking place in the classroom ~~or other setting~~.

For the school year in which a campus receives a request for video and audio surveillance, the campus shall continue to operate and maintain any video cameras placed in the classroom ~~or other setting~~ for as long as the classroom ~~or other setting~~ continues to satisfy the requirements in Education Code 29.022(a). However, the campus may discontinue operation of the video camera during the year if the requestor withdraws the request in writing and no request is submitted to continue the surveillance.

Video cameras must be capable of recording video and audio of all areas of the classroom, including a room attached to the classroom used for time out as defined by law. No visual monitoring, other than incidental coverage, ~~or setting, except that no video surveillance~~ shall be conducted of the inside of a bathroom or other area used for toileting or diapering a student or removing or changing a student's clothes.

The District may post notice at the entrance to a classroom ~~or other setting~~ in which video cameras are placed stating that video and audio surveillance is conducted in that classroom ~~or setting~~.

**Retention of
Recordings**

Video recordings shall be retained for at least ~~three~~ six months after the date of the recording but may be retained for a longer period in accordance with the District's records management program, or as required by law. [See CPC]

**Confidentiality of
Recordings**

Video recordings made in accordance with this policy shall be confidential and shall only be accessed or viewed by the individuals and in the limited circumstances permitted by law. ~~Contractors and District personnel with job duties related to the installation, operation, or maintenance of video equipment, or the retention of video recordings, who incidentally view recordings when performing regular job duties such as ensuring the proper functioning of the equipment or pulling specific footage shall not be considered in violation of the confidentiality provisions.~~

The following individuals shall have authority to view video recordings to the extent permitted by the Family Educational Rights and Privacy Act (FERPA):

1. A District employee or a parent of a student who is involved in an alleged incident documented by a recording and for which a complaint has been reported to the District;
2. Appropriate Department of Family and Protective Services (DFPS) personnel as part of an investigation of alleged abuse or neglect of a child;
3. A peace officer, school nurse, District administrator trained in de-escalation and restraint techniques, or human resource staff member in response to a report of an alleged incident-complaint or an investigation of an employee or a report of alleged abuse committed by a student incident; and
4. Appropriate TEA or State Board for Educator Certification personnel or their agents as part of an investigation.

For purposes of this policy, the term "human resource staff member" shall include the Superintendent, a principal, an assistant principal or other campus administrator, and any supervisory position within the District's human resources office. If an individual listed in items 2 through 4 above believes that a recording shows a violation of District policy or campus procedures, the individual may allow access to the recording by appropriate legal and human resources personnel designated by the District for the purpose of determining whether a policy or procedure has been violated.

Any person who suspects that child abuse or neglect has occurred shall report this suspicion as required by law and District policy. [See FFG]

Reporting an Incident

A person alleging that an incident, as defined by law, has occurred in a classroom or other setting in which video surveillance is conducted shall file a report on the form provided by the District with the principal as soon as possible after the person suspects the alleged incident. If possible, an incident report form shall be filed within 48 hours of the facts giving rise to the allegation. The principal shall promptly view, or direct an authorized individual to view, the video surveillance footage to identify the relevant portion of the recording. No later than ten District business days after the report is filed, the principal or designee shall respond by notifying the person whether the alleged incident was recorded in the District's video surveillance footage and shall initiate other steps as required by law, District policy, or local procedures.

Lamar CISD
079901

SPECIAL EDUCATION
VIDEO/AUDIO MONITORING

EHBAF
(LOCAL)

Complaints

Complaints related to video and audio recordings under this policy shall be filed in accordance with DGBA, FNG, or GF, as applicable. A complainant who is dissatisfied with the outcome of the District's complaint process may appeal in writing to the commissioner of education in accordance with Education Code 7.057, including requesting an expedited review.

DATE ISSUED: 11/21/2017 ~~12/22/2016~~
UPDATE 109 ~~LDU 2016.09~~
EHBAF(LOCAL)-X

ADOPTED:

4 of 4

DELETE

ACADEMIC GUIDANCE PROGRAM

EJ
(LOCAL)

GUIDANCE AND COUNSELING SERVICES

The District's guidance and counseling services shall be designed primarily to provide ongoing assistance to enhance the educational development of all students and shall be included in and monitored through the District and campus planning process. [See BQ series]

AREAS OF STUDENT NEED

The services may assist individuals or groups of students in:

1. Improving academic achievement.
2. Improving school attendance.
3. Improving school attitudes.
4. Developing self-confidence.
5. Developing healthy interpersonal relationships.
6. Developing life satisfaction.
7. Obtaining information to assist in choosing a potential career.

Guidance services shall be coordinated with the regular instructional program so that they contribute to a unified educational program. Guidance services shall operate with central coordination and shall be a cooperative project of the entire professional staff. Teachers shall use opportunities in the classroom, in extracurricular activities, and in contacts with parents to achieve guidance objectives. Qualified counselors shall supervise the standardized testing program and provide personal, academic, and career guidance to students who need such services. [See FFE]

**ATTENDANCE
COMPULSORY ATTENDANCE**

**FEA
(LOCAL)**

Students in violation of the compulsory attendance law shall be reported to the District attendance officer, who may institute court action as provided by law.

EXCUSED ABSENCES

In addition to excused absences required by law, the District shall excuse absences for the following purposes.

**HIGHER
EDUCATION VISITS**

The District shall excuse a student for up to two days during the student's junior year and up to two days during the student's senior year to visit an accredited institution of higher education. A student shall be required to submit verification of such visits in accordance with administrative regulations.

**EARLY VOTING OR
ELECTION CLERK**

The District shall excuse a student for up to two days per school year to serve as an early voting or election clerk. A student shall be required to submit verification of service in accordance with administrative regulations.

[For extracurricular activity absences, see FM.]

**WITHDRAWAL FOR
NONATTENDANCE**

The District may initiate withdrawal of a student under the age of 19 for nonattendance under the following conditions:

1. The student has been absent ten consecutive school days; and
2. Repeated efforts by the attendance officer and/or principal to locate the student have been unsuccessful.

[For District-initiated withdrawal of students 19 or older, see FEA(LEGAL).]

**STUDENTS
ATTENDING
HOMESCHOOLS**

Students who are homeschooled are exempt from the compulsory attendance law to the same extent as students enrolled in other private schools.

Adequate documentation of homeschooling for withdrawal shall consist of either a statement of withdrawal in accordance with FD(LOCAL) indicating the date homeschooling began, or a signed and dated letter from a parent or guardian indicating that his or her child is being homeschooled and the date the homeschooling began.

The District may request from a parent or guardian a letter of assurance that a child is being educated using a curriculum designed to meet basic education goals of reading, spelling, grammar, mathematics, and a study of good citizenship.

**ENFORCING
COMPULSORY
ATTENDANCE**

If a parent or guardian refuses to submit a requested statement or letter, or if the District has evidence that a school-aged child is not being homeschooled within legal requirements, the District may

ATTENDANCE
COMPULSORY ATTENDANCE

FEA
(LOCAL)

investigate further and, if warranted, shall pursue legal action to enforce the compulsory attendance law.

Students in violation of the compulsory attendance law shall be reported to the District attendance officer, who may institute court action as provided by law.

Excused Absences

In addition to excused absences required by law, the District shall excuse absences for the following purposes.

Higher Education
Visits

The District shall excuse a student for up to two days during the student's junior year and up to two days during the student's senior year to visit an accredited institution of higher education. A student shall be required to submit verification of such visits in accordance with administrative regulations.

Armed Services
Enlistment

The District shall excuse a student 17 years of age or older for up to four days during a school year for activities related to pursuing enlistment in a branch of the U.S. Armed Services or Texas National Guard. A student shall be required to submit verification of such activities in accordance with administrative regulations.

Early Voting or
Election Clerk

The District shall excuse a student for up to two days per school year to serve as an early voting or election clerk. A student shall be required to submit verification of service in accordance with administrative regulations.

[For extracurricular activity absences, see FM.]

**Withdrawal for
Nonattendance**

The District may initiate withdrawal of a student under the age of 19 for nonattendance under the following conditions:

1. The student has been absent ten consecutive school days; and
2. Repeated efforts by the attendance officer and/or principal to locate the student have been unsuccessful.

[For District-initiated withdrawal of students 19 or older, see FEA(LEGAL).]

**Students Attending
Homeschools**

Students who are homeschooled are exempt from the compulsory attendance law to the same extent as students enrolled in other private schools.

Adequate documentation of homeschooling for withdrawal shall consist of either a statement of withdrawal in accordance with FD(LOCAL) indicating the date homeschooling began, or a signed and dated letter from a parent or guardian indicating that his or her child is being homeschooled and the date the homeschooling began.

The District may request from a parent or guardian a letter of assurance that a child is being educated using a curriculum designed

Lamar CISD
079901

ATTENDANCE
COMPULSORY ATTENDANCE

FEA
(LOCAL)

to meet basic education goals of reading, spelling, grammar, mathematics, and a study of good citizenship.

Enforcing
Compulsory
Attendance

If a parent or guardian refuses to submit a requested statement or letter, or if the District has evidence that a school-aged child is not being homeschooled within legal requirements, the District may investigate further and, if warranted, shall pursue legal action to enforce the compulsory attendance law.

**WELLNESS AND HEALTH SERVICES
PHYSICAL EXAMINATIONS**

**FFAA
(LOCAL)**

UIL PARTICIPATION	A student desiring to participate in the UIL athletic program shall submit annually a statement from a licensed physician, physician's assistant, or nurse practitioner authorized under UIL rules indicating that the student has been examined and is physically able to participate in the athletic program.
ADDITIONAL SCREENING	The Superintendent shall implement the guidelines recommended by the Texas Department of Health for vision, hearing, spinal, and acanthosis nigricans screening. In addition to the required screening, and to the extent District resources allow, the Superintendent may implement screening for: <ol style="list-style-type: none">1. Additional grade levels as deemed necessary by the District.2. Students referred by teachers, parents, or others.3. Students exhibiting symptoms related to a designated screening.4. Students who repeat a grade.
REFERRALS	Parents of students who are identified through any screening program as needing treatment or further examination shall be advised of the need and referred to appropriate health agencies. The person performing the screening shall send a report indicating the finding to the minor student's parent, managing conservator, guardian, or, if the student is 18 years or older or an emancipated minor, to the student.
ANNUAL REPORT	In addition to the information required in the annual report to the Texas-Mexico Border Health Coordination Office (TMBHCO), each campus shall submit to the TMBHCO information on the acanthosis nigricans screening status of students in attendance during the reporting year. The report shall be on a form prescribed by the executive council advising the TMBHCO and submitted according to the executive council's rules.
STUDENT TUBERCULOSIS SCREENING	Students enrolling from countries outside the United States shall present proof of a current negative tuberculin skin test prior to enrollment. When the tuberculin skin test is positive, students should show proof of a chest x-ray that is negative for active tuberculosis prior to enrollment. Any indication that a positive tuberculin skin test will occur such as a reaction from a BCG vaccination would indicate a chest x-ray. Students who have a positive tuberculin skin test, and a negative chest x-ray may be enrolled in the District when they present proof that they are receiving prophylactic treatment from the Fort Bend County Health Department and/or a family physician.

WELLNESS AND HEALTH SERVICES
PHYSICAL EXAMINATIONS

FFAA
(LOCAL)

Students who have been diagnosed with active tuberculosis may not attend District schools until they present proof from a physician that they are not considered contagious and may return to school.

The District may require any student to have a tuberculin skin test or chest x-ray whenever it is reasonably believed that the student may be suffering from tuberculosis or may have been exposed to tuberculosis.

UIL Participation A student desiring to participate in the UIL athletic program shall submit annually a statement from a ~~health-care provider~~^{licensed physician, physician's assistant, or nurse practitioner} authorized under UIL rules indicating that the student has been examined and is physically able to participate in the athletic program.

Additional Screening The Superintendent shall implement the guidelines recommended by the Texas Department of Health for vision, hearing, spinal, and acanthosis nigricans screening. In addition to the required screening, and to the extent District resources allow, the Superintendent may implement screening for:

1. Additional grade levels as deemed necessary by the District.
2. Students referred by teachers, parents, or others.
3. Students exhibiting symptoms related to a designated screening.
4. Students who repeat a grade.

Referrals Parents of students who are identified through any screening program as needing treatment or further examination shall be advised of the need and referred to appropriate health agencies. The person performing the screening shall send a report indicating the finding to the minor student's parent, managing conservator, guardian, or, if the student is 18 years or older or an emancipated minor, to the student.

Notice of Lice A school nurse or administrator who discovers or becomes aware that a child enrolled in a District elementary school has lice shall provide written or electronic notice to parents within the time frames prescribed in law.

Annual Report In addition to the information required in the annual report to the Texas-Mexico Border Health Coordination Office (TMBHCO), each campus shall submit to the TMBHCO information on the acanthosis nigricans screening status of students in attendance during the reporting year. The report shall be on a form prescribed by the executive council advising the TMBHCO and submitted according to the executive council's rules.

Student Tuberculosis Screening Students enrolling from countries outside the United States shall present proof of a current negative tuberculin skin test prior to enrollment.

When the tuberculin skin test is positive, students should show proof of a chest x-ray that is negative for active tuberculosis prior to enrollment. Any indication that a positive tuberculin skin test will occur such as a reaction from a BCG vaccination would indicate a

chest x-ray. Students who have a positive tuberculin skin test, and a negative chest x-ray may be enrolled in the District when they present proof that they are receiving prophylactic treatment from the Fort Bend County Health Department and/or a family physician.

Students who have been diagnosed with active tuberculosis may not attend District schools until they present proof from a physician that they are not considered contagious and may return to school.

The District may require any student to have a tuberculin skin test or chest x-ray whenever it is reasonably believed that the student may be suffering from tuberculosis or may have been exposed to tuberculosis.

ADD

STUDENT WELFARE
STUDENT SAFETY

FFF
(LOCAL)

The District shall notify a parent of a student with whom an educator is alleged to have engaged in misconduct, informing the parent:

1. As soon as feasible that the alleged misconduct may have occurred;
2. Whether the educator was terminated following an investigation of the alleged misconduct or resigned before completion of the investigation; and
3. Whether a report was submitted to the State Board for Educator Certification (SBEC) concerning the alleged misconduct.

For purposes of this policy, misconduct is defined as an educator's alleged abuse or commission of an otherwise unlawful act with the student or involvement in a romantic relationship, or soliciting or engaging in sexual contact with the student.

[See also FFG for reporting requirements related to child abuse and FFH for parental notification requirements regarding prohibited conduct as defined by that policy.]

Note: This policy addresses bullying of District students. For provisions regarding discrimination and harassment involving District students, see FFH. Note that FFI shall be used in conjunction with FFH for certain prohibited conduct. For reporting requirements related to child abuse and neglect, see FFG.

BULLYING
PROHIBITED

The District prohibits bullying as defined by this policy. Retaliation against anyone involved in the complaint process is a violation of District policy and is prohibited.

DEFINITION

Bullying occurs when a student or group of students engages in written or verbal expression, expression through electronic means, or physical conduct that occurs on school property, at a school-sponsored or school-related activity, or in a vehicle operated by the District and that:

1. Has the effect or will have the effect of physically harming a student, damaging a student's property, or placing a student in reasonable fear of harm to the student's person or of damage to the student's property; or
2. Is sufficiently severe, persistent, and pervasive enough that the action or threat creates an intimidating, threatening, or abusive educational environment for a student.

This conduct is considered bullying if it:

1. Exploits an imbalance of power between the student perpetrator and the student victim through written or verbal expression or physical conduct; and
2. Interferes with a student's education or substantially disrupts the operation of a school.

EXAMPLES

Bullying of a student may include hazing, threats, taunting, teasing, confinement, assault, demands for money, destruction of property, theft of valued possessions, name calling, rumor spreading, or ostracism.

RETALIATION

The District prohibits retaliation by a student or District employee against any person who in good faith makes a report of bullying, serves as a witness, or participates in an investigation.

EXAMPLES

Examples of retaliation may include threats, rumor spreading, ostracism, assault, destruction of property, unjustified punishments, or unwarranted grade reductions. Unlawful retaliation does not include petty slights or annoyances.

STUDENT WELFARE
FREEDOM FROM BULLYING

FFI
(LOCAL)

FALSE CLAIM	A student who intentionally makes a false claim, offers false statements, or refuses to cooperate with a District investigation regarding bullying shall be subject to appropriate disciplinary action.
TIMELY REPORTING	Reports of bullying shall be made as soon as possible after the alleged act or knowledge of the alleged act. A failure to immediately report may impair the District's ability to investigate and address the prohibited conduct.
REPORTING PROCEDURES	To obtain assistance and intervention, any student who believes that he or she has experienced bullying or believes that another student has experienced bullying should immediately report the alleged acts to a teacher, counselor, principal, or other District employee.
STUDENT REPORT	
EMPLOYEE REPORT	Any District employee who suspects or receives notice that a student or group of students has or may have experienced bullying shall immediately notify the principal or designee.
REPORT FORMAT	A report may be made orally or in writing. The principal or designee shall reduce any oral reports to written form.
PROHIBITED CONDUCT	The principal or designee shall determine whether the allegations in the report, if proven, would constitute prohibited conduct as defined by policy FFH, including dating violence and harassment or discrimination on the basis of race, color, religion, gender, national origin, or disability. If so, the District shall proceed under policy FFH. If the allegations could constitute both prohibited conduct and bullying, the investigation under FFH shall include a determination on each type of conduct.
INVESTIGATION OF REPORT	The principal or designee shall conduct an appropriate investigation based on the allegations in the report. The principal or designee shall promptly take interim action calculated to prevent bullying during the course of an investigation, if appropriate.
CONCLUDING THE INVESTIGATION	Absent extenuating circumstances, the investigation should be completed within ten District business days from the date of the initial report alleging bullying; however, the principal or designee shall take additional time if necessary to complete a thorough investigation.
	The principal or designee shall prepare a final, written report of the investigation. The report shall include a determination of whether bullying occurred, and if so, whether the victim used reasonable self-defense. A copy of the report shall be sent to the Superintendent or designee.
NOTICE TO PARENTS	If an incident of bullying is confirmed, the principal or designee shall promptly notify the parents of the victim and of the student who engaged in bullying.

STUDENT WELFARE
FREEDOM FROM BULLYING

FFI
(LOCAL)

DISTRICT ACTION BULLYING	If the results of an investigation indicate that bullying occurred, the District shall promptly respond by taking appropriate disciplinary action in accordance with the District's Student Code of Conduct and may take corrective action reasonably calculated to address the conduct.
DISCIPLINE	<p>A student who is a victim of bullying and who used reasonable self-defense in response to the bullying shall not be subject to disciplinary action.</p> <p>The discipline of a student with a disability is subject to applicable state and federal law in addition to the Student Code of Conduct.</p>
CORRECTIVE ACTION	Examples of corrective action may include a training program for the individuals involved in the complaint, a comprehensive education program for the school community, follow-up inquiries to determine if any new incidents or any instances of retaliation have occurred, involving parents and students in efforts to identify problems and improve the school climate, increasing staff monitoring of areas where bullying has occurred, and reaffirming the District's policy against bullying.
TRANSFERS	The principal or designee shall refer to FDB for transfer provisions.
COUNSELING	The principal or designee shall notify the victim, the student who engaged in bullying, and any students who witnessed the bullying of available counseling options.
IMPROPER CONDUCT	If the investigation reveals improper conduct that did not rise to the level of prohibited conduct or bullying, the District may take action in accordance with the Student Code of Conduct or any other appropriate corrective action.
CONFIDENTIALITY	To the greatest extent possible, the District shall respect the privacy of the complainant, persons against whom a report is filed, and witnesses. Limited disclosures may be necessary in order to conduct a thorough investigation.
APPEAL	A student who is dissatisfied with the outcome of the investigation may appeal through FNG(LOCAL), beginning at the appropriate level.
RECORDS RETENTION	Retention of records shall be in accordance with CPC(LOCAL).
ACCESS TO POLICY AND PROCEDURES	This policy and any accompanying procedures shall be distributed annually in the employee and student handbooks. Copies of the policy and procedures shall be posted on the District's Web site, to the extent practicable, and shall be readily available at each campus and the District's administrative offices.

Note: This policy addresses bullying of District students. For purposes of this policy, the term bullying includes cyber-bullying.

For provisions regarding discrimination and harassment involving District students, see FFH. Note that FFI shall be used in conjunction with FFH for certain prohibited conduct. For reporting requirements related to child abuse and neglect, see FFG.

~~**Note:** This policy addresses bullying of District students. For provisions regarding discrimination and harassment involving District students, see FFH. Note that FFI shall be used in conjunction with FFH for certain prohibited conduct. For reporting requirements related to child abuse and neglect, see FFG.~~

Bullying Prohibited

The District prohibits bullying, including cyberbullying, as defined by state law ~~this policy~~. Retaliation against anyone involved in the complaint process is a violation of District policy and is prohibited.

Definition

~~Bullying occurs when a student or group of students engages in written or verbal expression, expression through electronic means, or physical conduct that occurs on school property, at a school-sponsored or school-related activity, or in a vehicle operated by the District and that:~~

- ~~1. Has the effect or will have the effect of physically harming a student, damaging a student's property, or placing a student in reasonable fear of harm to the student's person or of damage to the student's property; or~~
- ~~2. Is sufficiently severe, persistent, and pervasive enough that the action or threat creates an intimidating, threatening, or abusive educational environment for a student.~~

~~This conduct is considered bullying if it:~~

- ~~1. Exploits an imbalance of power between the student perpetrator and the student victim through written or verbal expression or physical conduct; and~~
- ~~2. Interferes with a student's education or substantially disrupts the operation of a school.~~

Examples

Bullying of a student could occur by physical contact or through electronic means and may include hazing, threats, taunting, teas-

ing, confinement, assault, demands for money, destruction of property, theft of valued possessions, name calling, rumor spreading, or ostracism.

Retaliation

The District prohibits retaliation by a student or District employee against any person who in good faith makes a report of bullying, serves as a witness, or participates in an investigation.

Examples

Examples of retaliation may include threats, rumor spreading, ostracism, assault, destruction of property, unjustified punishments, or unwarranted grade reductions. Unlawful retaliation does not include petty slights or annoyances.

False Claim

A student who intentionally makes a false claim, offers false statements, or refuses to cooperate with a District investigation regarding bullying shall be subject to appropriate disciplinary action.

Timely Reporting

Reports of bullying shall be made as soon as possible after the alleged act or knowledge of the alleged act. A failure to immediately report may impair the District's ability to investigate and address the prohibited conduct.

Reporting Procedures

Student Report

To obtain assistance and intervention, any student who believes that he or she has experienced bullying or believes that another student has experienced bullying should immediately report the alleged acts to a teacher, school counselor, principal, or other District employee. [The Superintendent shall develop procedures allowing a student to anonymously report an alleged incident of bullying.](#)

Employee Report

Any District employee who suspects or receives notice that a student or group of students has or may have experienced bullying shall immediately notify the principal or designee.

Report Format

A report may be made orally or in writing. The principal or designee shall reduce any oral reports to written form.

Notice of Report

[When an allegation of bullying is reported, the principal or designee shall notify a parent of the alleged victim on or before the third business day after the incident is reported. The principal or designee shall also notify a parent of the student alleged to have engaged in the conduct within a reasonable amount of time after the incident is reported.](#)

Prohibited Conduct

The principal or designee shall determine whether the allegations in the report, if proven, would constitute prohibited conduct as defined by policy FFH, including dating violence and harassment or discrimination on the basis of race, color, religion, sex, gender, national origin, or disability. If so, the District shall proceed under policy FFH. If the allegations could constitute both prohibited conduct

	and bullying, the investigation under FFH shall include a determination on each type of conduct.
Investigation of Report	The principal or designee shall conduct an appropriate investigation based on the allegations in the report. The principal or designee shall promptly take interim action calculated to prevent bullying during the course of an investigation, if appropriate.
Concluding the Investigation	<p>Absent extenuating circumstances, the investigation should be completed within ten District business days from the date of the initial report alleging bullying; however, the principal or designee shall take additional time if necessary to complete a thorough investigation.</p> <p>The principal or designee shall prepare a final, written report of the investigation. The report shall include a determination of whether bullying occurred, and if so, whether the victim used reasonable self-defense. A copy of the report shall be sent to the Superintendent or designee.</p>
Notice to Parents	If an incident of bullying is confirmed, the principal or designee shall promptly notify the parents of the victim and of the student who engaged in bullying.
District Action	If the results of an investigation indicate that bullying occurred, the District shall promptly respond by taking appropriate disciplinary action in accordance with the District's Student Code of Conduct and may take corrective action reasonably calculated to address the conduct. The District may notify law enforcement in certain circumstances.
<i>Bullying</i>	
<i>Discipline</i>	<p>A student who is a victim of bullying and who used reasonable self-defense in response to the bullying shall not be subject to disciplinary action.</p> <p>The discipline of a student with a disability is subject to applicable state and federal law in addition to the Student Code of Conduct.</p>
<i>Corrective Action</i>	Examples of corrective action may include a training program for the individuals involved in the complaint, a comprehensive education program for the school community, follow-up inquiries to determine whether if any new incidents or any instances of retaliation have occurred, involving parents and students in efforts to identify problems and improve the school climate, increasing staff monitoring of areas where bullying has occurred, and reaffirming the District's policy against bullying.
<i>Transfers</i>	The principal or designee shall refer to FDB for transfer provisions.
<i>Counseling</i>	

The principal or designee shall notify the victim, the student who engaged in bullying, and any students who witnessed the bullying of available counseling options.

Improper Conduct If the investigation reveals improper conduct that did not rise to the level of prohibited conduct or bullying, the District may take action in accordance with the Student Code of Conduct or any other appropriate corrective action.

Confidentiality To the greatest extent possible, the District shall respect the privacy of the complainant, persons against whom a report is filed, and witnesses. Limited disclosures may be necessary in order to conduct a thorough investigation.

Appeal A student who is dissatisfied with the outcome of the investigation may appeal through FNG(LOCAL), beginning at the appropriate level.

Records Retention Retention of records shall be in accordance with CPC(LOCAL).

Access to Policy and Procedures This policy and any accompanying procedures shall be distributed annually in the employee and student handbooks. Copies of the policy and procedures shall be posted on the District's websiteWeb site, to the extent practicable, and shall be readily available at each campus and the District's administrative offices.

INFORMATION ACCESS
REQUESTS FOR INFORMATION

GBAA
(LOCAL)

CHARGING FOR
PERSONNEL TIME

After personnel of the District collectively have spent 36 hours of time producing public information for a requestor during the District's fiscal year, the District shall charge the requestor for any additional personnel time spent producing information for the requestor, in accordance with law.

INFORMATION ACCESS
REQUESTS FOR INFORMATION

GBAA
(LOCAL)

CHARGING
FOR PERSONNEL
TIME

As authorized by law, after personnel of the District collectively have spent 36 hours of time producing public information for a requestor during the District's fiscal year, the District shall charge the requestor for any additional personnel time spent producing information for the requestor after personnel of the District have collectively spent:

1. 36 hours of time during the District's fiscal year; or
15 hours of time during a one-month period, in accordance with law.

INFORMATION ACCESS
REQUESTS FOR INFORMATION

GBAA
(REGULATION)

REQUESTS FOR
INFORMATION

Persons desiring to review documents maintained by the District and classified as Public Information may submit their requests, in writing, on forms provided by the District [see GBAA(EXHIBIT)], or in any other written manner that sets forth the required information. The request must properly identify the document, or documents, to be inspected.

The requestor's name and address must appear on the request. A photo identification card, such as a driver's license, may be required to verify the person's identity.

Requests will be handled in the order in which they are received.

FEES

A schedule of charges for any requested copies of records will be made available to all persons requesting records. [See GBAA(EXHIBIT)] If the cost of copies will exceed \$40, the District will prepare a written estimate of charges and the availability of any less expensive method for viewing the information. [See GBAA(EXHIBIT)] If an estimate of charges is necessary, the copies will be made available only if the requestor responds in writing within ten days to indicate that he or she modifies the request or is willing to accept the charges and still wants the copies as originally requested. Payment must be made to the officer for public records.

DOCUMENTS
UNAVAILABLE

In the event the requested documents are in active use or in storage and, therefore, are not available at the time the request to review documents is submitted, the Superintendent or designee will notify the requestor in writing and set a date and hour when the requested materials will be available for inspection. If the requested documents cannot be made available within ten business days after receipt of the request, the Superintendent or designee will notify the requestor of that fact in writing and set a date and hour within a reasonable time when the information will be available.

DESIGNATED
INSPECTION AREA
AND HOURS

Persons inspecting documents may do so only in a designated inspection area, with a District employee available for assistance. Documents may be inspected during regular school hours.

COPY LIMIT

The Superintendent or designee may limit the number of pages that can be copied and supplied during a person's visit if the number of copies requested is beyond the reasonable capacity of the available personnel and machines. Copies in excess of the number available during a single visit will be made and mailed to the requestor.

COMMUNITY RELATIONS
CONDUCT ON SCHOOL PREMISES

GKA
(LOCAL)

Principals and other designated employees are authorized to:

1. Refuse entry onto school grounds to persons who do not have legitimate business at the school;
2. Request any unauthorized person or any person engaging in unacceptable conduct to leave the school grounds;
3. Request assistance of law enforcement officers in cases of emergency; and
4. Seek prosecution for violations of law as permitted by statute.

OFF-CAMPUS
ACTIVITIES

Employees shall be designated to ensure appropriate conduct of participants and others attending a school-related activity at non-District or out-of-District facilities. Those so designated shall coordinate their efforts with persons in charge of the facilities.

PROHIBITIONS
TOBACCO AND
E-CIGARETTES

The District prohibits smoking and the use of tobacco products and e-cigarettes on District property, in District vehicles, or at school-related activities.

WEAPONS

The District prohibits the unlawful use, possession, or display of any firearm, illegal knife, club, or prohibited weapon, as defined at FNCG, on all District property at all times.

EXCEPTION

No violation of this policy occurs when the use, possession, or display of an otherwise prohibited weapon takes place as part of a District-approved activity supervised by proper authorities. [See FOD]

~~Campus Principals~~ and District administrators, as well as ~~other designated employees~~ are authorized to:

~~2. Refuse entry onto~~ school resource officers and District police officers if applicable, may refuse to allow ~~agrounds to persons who do not have legitimate business at the school;~~

~~3.1. Request any unauthorized~~ person to enter or may eject ~~any~~ person from property under the District's control ~~engaging~~ in accordance with law. ~~unacceptable conduct to leave the school grounds;~~

~~4. District personnel may request~~ Request assistance ~~from~~ of law enforcement ~~officers in~~ ~~ancases of~~ emergency or when a person is engaging in behavior rising to the level of criminal conduct; ~~and~~

~~5.2. Seek prosecution for violations of law as permitted by statute.~~

Off-Campus Activities

Employees shall be designated to ensure appropriate conduct of participants and others attending a school-related activity at non-District or out-of-District facilities. Those so designated shall coordinate their efforts with persons in charge of the facilities.

Prohibitions

Tobacco and E-Cigarettes

The District prohibits smoking and the use of tobacco products and e-cigarettes on District property, in District vehicles, or at school-related activities.

Weapons

The District prohibits the unlawful use, possession, or display of any firearm, ~~location-restricted~~ ~~illegal~~ knife, club, or prohibited weapon, as defined at FNCG, on all District property at all times.

Exceptions

No violation of this policy occurs when:

Exception

1. A Texas handgun license holder stores a handgun or other firearm in a locked vehicle in a parking lot, parking garage, or other parking area owned or provided by the District, as long as the handgun or other firearm is not loaded and not in plain view; or

The use, possession, or display of an otherwise prohibited weapon takes place as part of a District-approved activity supervised by proper authorities. [See FOD]

COMMUNITY RELATIONS
VISITORS TO THE SCHOOLS

GKC
(LOCAL)

Visitors shall report first to the school office. Any person on school property who has not registered with the school office is illegally on school property and shall be asked to identify himself or herself properly or to leave the school grounds. If the visitor refuses to leave the school grounds or creates any disturbance, the principal may request aid from the law enforcement agency.

REGISTERED SEX
OFFENDERS ON
DISTRICT PREMISES

The Superintendent, working with campus administrators, shall develop and implement procedures regarding campus visitors who are identified as sex offenders. These procedures shall address:

1. Parental rights;
2. Escort by District personnel;
3. Access to common areas of the campus;
4. Access to classrooms;
5. Drop off and release of students;
6. Eligibility to serve as volunteers; and
7. Any other relevant issues.

REVISED

Lamar CISD
079901

COMMUNITY RELATIONS
VISITORS ~~TO THE SCHOOLS~~

GKC
(LOCAL)

Prominent notices shall be posted at each campus requiring all visitors to first report to the campus main office. This shall apply to parents, volunteers, social service workers, invited speakers, maintenance and repair persons not employed by the District, vendors, representatives of the news media, former students, and any other visitors. Visits to individual classrooms during instructional time shall be permitted only with the principal's and teacher's approval, and such visits shall not be permitted if their duration or frequency interferes with the delivery of instruction or disrupts the normal classroom environment.

[See BBE(LOCAL) for visits to District facilities by Board members.]

~~Visitors shall report first to the school office. Any person on school property who has not registered with the school office is illegally on school property and shall be asked to identify himself or herself properly or to leave the school grounds. If the visitor refuses to leave the school grounds or creates any disturbance, the principal may request aid from the law enforcement agency.~~

**Registered Sex
Offender**~~Offenders~~
**on a School
Campus**~~District~~
Premises

The Superintendent ~~and~~ ~~, working with~~ campus administrators, shall develop and implement procedures regarding a campus ~~visi-~~torvisitors who is ~~registered~~are identified as a sex offender~~offend-~~ers. These procedures shall address:

1. Parental rights;
2. Escort by District personnel;
3. Access to common areas of the campus;
4. Access to classrooms;
5. Drop off and release of students;
6. Eligibility to serve as volunteers; and
7. Any other relevant issues.

DATE ISSUED:
11/21/2017~~10/4/2007~~
UPDATE 10984
GKC(LOCAL)-~~AX~~

ADOPTED:

1 of 1

ADD

COMMUNITY RELATIONS
BUSINESS , CIVIC, AND YOUTH GROUPS

GKE
(LOCAL)

A campus principal shall have the authority to offer a representative of a patriotic society an opportunity to speak to students during regular school hours about membership in the society.

The principal shall have discretion over the date and time of such visits and is authorized to limit this opportunity to a single school day and to limit a presentation by a patriotic society to ten minutes in length.

[For more information about patriotic societies, see GKD(LEGAL).]

INFORMATION ITEM: TASB 2016 – 2018 ADVOCACY AGENDA

TASB's 2016 – 2018 Advocacy Agenda was amended by the 2017 Delegate Assembly. This agenda is the culmination of the hard work of school board members across the state through Grassroots Meetings in 2017, the Legislative Advisory Council meetings throughout the two-year agenda cycle, the resolutions process, and, ultimately, the Delegate Assembly. The TASB Advocacy Agenda represents input from trustees in every region of the state. This agenda will guide the Association's advocacy efforts until the 2018 Delegate Assembly approves the next biennial agenda.

A copy is provided under separate cover.

Resource Person: Dr. Thomas Randle, Superintendent

**INFORMATION ITEM: TAX COLLECTION REPORT
(AS OF DECEMBER 31, 2017)**

- Exhibit "A" gives the LCISD collections made during the month of December 31, 2017.
- Exhibit "B" gives the total LCISD collections made this school year from September 1, 2017 through August 31, 2018.
- Exhibit "C" shows the LCISD collections made month-by-month of the 2017-18 roll as compared to prior years. Through December 31, 2017, LCISD had collected 51.4 % of the 2017-18 roll.
- Exhibit "D" shows the total collections made as compared to the amount that was budgeted for 2017-2018.
- Exhibit "E" shows the LCISD tax collection analysis for the last six years.

Resource Person: Jill Ludwig, CPA, RTSBA, Chief Financial Officer

**Lamar Consolidated ISD
Tax Collections
December 2017**

Exhibit A

Year	Taxes Paid	Penalty & Interest	Collection Fees	Total Payments	General Fund Taxes Paid	General Fund P & I & Collection Fees	Debt Service Taxes Paid	Debt Service P & I & Collection Fees
17	\$ 106,956,840.23	\$ -	\$ -	\$ 106,956,840.23	\$ 80,026,230.59	\$ -	\$ 26,930,609.64	\$ -
16	\$ 69,135.21	\$ 17,088.78	\$ 20,166.81	\$ 106,390.80	\$ 51,727.71	\$ 32,952.91	\$ 17,407.50	\$ 4,302.68
15	\$ 5,891.33	\$ 5,709.67	\$ 4,420.62	\$ 16,021.62	\$ 4,407.89	\$ 8,692.67	\$ 1,483.44	\$ 1,437.62
14	\$ 538.46	\$ 3,804.45	\$ 2,443.78	\$ 6,786.69	\$ 402.80	\$ 5,290.28	\$ 135.66	\$ 957.95
13	\$ (3,763.56)	\$ 2,354.41	\$ 1,321.31	\$ (87.84)	\$ (2,815.96)	\$ 3,082.94	\$ (947.60)	\$ 592.78
12	\$ 16,282.50	\$ 2,145.25	\$ 994.20	\$ 19,421.95	\$ 12,182.74	\$ 2,599.29	\$ 4,099.76	\$ 540.16
11	\$ 3,107.90	\$ 969.70	\$ 441.12	\$ 4,518.72	\$ 2,280.63	\$ 1,152.71	\$ 827.27	\$ 258.11
10	\$ 0.96	\$ 0.91	\$ -	\$ 1.87	\$ 0.70	\$ 0.68	\$ 0.26	\$ 0.23
09	\$ 7.72	\$ 8.19	\$ 3.18	\$ 19.09	\$ 6.07	\$ 9.62	\$ 1.65	\$ 1.75
08	\$ 9.45	\$ 4.97	\$ 1.83	\$ 16.25	\$ 7.43	\$ 5.74	\$ 2.02	\$ 1.06
07	\$ 28.96	\$ 35.96	\$ 12.72	\$ 77.64	\$ 22.32	\$ 40.44	\$ 6.64	\$ 8.24
06	\$ 4.33	\$ -	\$ -	\$ 4.33	\$ 3.72	\$ -	\$ 0.61	\$ -
05	\$ 832.78	\$ 1,226.78	\$ 387.65	\$ 2,447.21	\$ 702.91	\$ 1,423.00	\$ 129.87	\$ 191.43
04	\$ 564.83	\$ 898.98	\$ 276.41	\$ 1,740.22	\$ 477.07	\$ 1,035.60	\$ 87.76	\$ 139.79
03	\$ 586.64	\$ 1,015.06	\$ 229.75	\$ 1,831.45	\$ 499.75	\$ 1,094.86	\$ 86.89	\$ 149.95
02	\$ -	\$ -	\$ -	\$ -	\$ -	\$ -	\$ -	\$ -
01	\$ 266.79	\$ 517.46	\$ 111.47	\$ 895.72	\$ 266.56	\$ 628.93	\$ 0.23	\$ -
00	\$ 1.82	\$ -	\$ -	\$ 1.82	\$ 1.62	\$ -	\$ 0.20	\$ -
99	\$ -	\$ -	\$ -	\$ -	\$ -	\$ -	\$ -	\$ -
98	\$ -	\$ -	\$ -	\$ -	\$ -	\$ -	\$ -	\$ -
97 & prior	\$ -	\$ -	\$ -	\$ -	\$ -	\$ -	\$ -	\$ -
Totals	\$ 107,050,336.35	\$ 35,780.57	\$ 30,810.85	\$ 107,116,927.77	\$ 80,096,404.55	\$ 58,009.67	\$ 26,953,931.80	\$ 8,581.75

**Lamar Consolidated ISD
Tax Collections
September 1, 2017-August 31, 2018
(Year-To-Date)**

Exhibit B

Year	Original Tax	Adjustments	Adjusted Tax	Taxes Paid	Penalty & Interest	Collection Fees	Total Payments	Total Taxes 12/31/17
17	\$ 206,293,212.17	\$ 4,237,448.53	\$ 210,530,660.70	\$ 108,107,859.05	\$ -	\$ -	\$ 108,107,859.05	\$ 102,422,801.65
16	\$ 1,814,663.85	\$ 15,284.80	\$ 1,829,948.65	\$ 499,157.33	\$ 105,508.17	\$ 115,534.33	\$ 720,199.83	\$ 1,330,791.32
15	\$ 566,874.61	\$ 18,623.38	\$ 585,497.99	\$ 27,372.90	\$ 24,268.36	\$ 17,947.40	\$ 69,588.66	\$ 558,125.09
14	\$ 339,577.64	\$ 77,625.68	\$ 417,203.32	\$ 20,395.66	\$ 9,545.47	\$ 5,680.82	\$ 35,621.95	\$ 396,807.66
13	\$ 277,679.16	\$ 77,390.07	\$ 355,069.23	\$ 9,766.10	\$ 7,253.64	\$ 3,820.76	\$ 20,840.50	\$ 345,303.13
12	\$ 265,479.02	\$ 80,624.42	\$ 346,103.44	\$ 43,230.05	\$ 7,082.73	\$ 2,841.97	\$ 53,154.75	\$ 302,873.39
11	\$ 224,190.26	\$ 20,101.02	\$ 244,291.28	\$ 15,495.04	\$ 4,480.67	\$ 1,411.47	\$ 21,387.18	\$ 228,796.24
10	\$ 181,303.11	\$ 4,352.89	\$ 185,656.00	\$ 6,543.86	\$ 4,050.36	\$ 816.70	\$ 11,410.92	\$ 179,112.14
09	\$ 159,154.16	\$ -	\$ 159,154.16	\$ 4,713.60	\$ 3,643.47	\$ 671.75	\$ 9,028.82	\$ 154,440.56
08	\$ 153,187.47	\$ -	\$ 153,187.47	\$ 1,535.58	\$ 1,674.66	\$ 562.90	\$ 3,773.14	\$ 151,651.89
07	\$ 174,543.62	\$ -	\$ 174,543.62	\$ 150.03	\$ 188.22	\$ 66.91	\$ 405.16	\$ 174,393.59
06	\$ 84,556.70	\$ -	\$ 84,556.70	\$ 1,088.14	\$ 924.24	\$ -	\$ 2,012.38	\$ 83,468.56
05	\$ 130,312.15	\$ -	\$ 130,312.15	\$ 883.40	\$ 1,301.85	\$ 411.94	\$ 2,597.19	\$ 129,428.75
04	\$ 52,136.73	\$ -	\$ 52,136.73	\$ 636.66	\$ 1,018.21	\$ 314.62	\$ 1,969.49	\$ 51,500.07
03	\$ 39,258.30	\$ -	\$ 39,258.30	\$ 932.68	\$ 1,466.42	\$ 301.02	\$ 2,700.12	\$ 38,325.62
02	\$ 25,886.38	\$ -	\$ 25,886.38	\$ 389.78	\$ 618.25	\$ 116.15	\$ 1,124.18	\$ 25,496.60
01	\$ 24,301.80	\$ -	\$ 24,301.80	\$ 266.79	\$ 517.46	\$ 111.47	\$ 895.72	\$ 24,035.01
00	\$ 21,052.70	\$ -	\$ 21,052.70	\$ 21.40	\$ 41.51	\$ 9.16	\$ 72.07	\$ 21,031.30
99	\$ 21,924.25	\$ -	\$ 21,924.25	\$ -	\$ -	\$ -	\$ -	\$ 21,924.25
98	\$ 13,781.68	\$ -	\$ 13,781.68	\$ -	\$ -	\$ -	\$ -	\$ 13,781.68
97	\$ 12,114.62	\$ -	\$ 12,114.62	\$ -	\$ -	\$ -	\$ -	\$ 12,114.62
96	\$ 5,144.62	\$ -	\$ 5,144.62	\$ -	\$ -	\$ -	\$ -	\$ 5,144.62
95 & prior	\$ 17,571.87	\$ -	\$ 17,571.87	\$ 8.32	\$ 28.56	\$ 5.54	\$ 42.42	\$ 17,563.55
Totals	\$210,897,906.87	\$4,531,450.79	\$215,429,357.66	\$108,740,446.37	\$173,612.25	\$150,624.91	\$109,064,683.53	\$106,688,911.29

**LAMAR CONSOLIDATED INDEPENDENT SCHOOL DISTRICT
TAX COLLECTION ANALYSIS
PERCENT Y-T-D BY MONTH
FOR CURRENT LEVY ONLY**

MONTH	2017-2018	2016-2017	2015-2016	2014-2015	2013-2014	2012-13	2011-12	2010-11	2009-10	2008-09	2007-08	2006-07
SEPT	0.0%	0.0%	0.0%	0.0%	0.0%	0.0%	0.0%	0.0%	0.0%	0.0%	0.0%	0.0%
OCT	0.0%	0.0%	0.1%	0.0%	0.1%	0.0%	0.0%	0.0%	0.0%	0.0%	0.0%	0.0%
NOV	0.5%	3.2%	3.2%	2.2%	7.4%	1.9%	2.6%	3.9%	1.9%	1.7%	2.8%	2.1%
DEC	51.4%	50.3%	49.0%	45.3%	45.3%	33.1%	30.2%	33.3%	25.9%	35.4%	31.9%	29.7%
JAN		87.2%	83.9%	82.0%	86.2%	82.9%	82.3%	84.1%	80.7%	80.4%	59.6%	76.4%
FEB		95.6%	95.4%	95.1%	95.5%	95.5%	94.8%	94.3%	93.3%	92.8%	93.5%	93.3%
MAR		96.9%	96.9%	96.8%	97.0%	96.8%	96.4%	96.1%	95.0%	94.8%	95.1%	94.7%
APR		97.5%	97.6%	97.9%	97.8%	97.6%	97.1%	96.9%	96.0%	95.6%	95.9%	95.8%
MAY		98.2%	98.4%	98.2%	98.2%	98.1%	97.9%	97.6%	96.5%	96.4%	96.7%	96.5%
JUNE		98.6%	98.7%	98.6%	98.7%	98.6%	98.3%	98.2%	97.4%	97.2%	97.4%	97.3%
JULY		98.9%	99.0%	98.9%	99.0%	99.0%	98.7%	98.6%	98.0%	97.9%	98.0%	97.8%
AUG		99.1%	99.2%	99.0%	99.2%	99.1%	98.9%	98.8%	98.2%	98.2%	98.2%	98.2%

**LAMAR CONSOLIDATED INDEPENDENT SCHOOL DISTRICT
2017-18 TAX COLLECTIONS
AS OF DECEMBER 31, 2017**

TAX YEAR LCISD TAXES	SCHOOL YEAR	BUDGET AMOUNT	COLLECTIONS 12/31/2017	% OF BUDGET COLLECTED
2017	2017-2018	\$207,658,560	\$108,107,859	52.06%
2016 & Prior	2016-17 & Prior	\$2,150,000	\$ 632,587	29.42%
TOTAL		\$209,808,560	\$108,740,446	51.83%

**LAMAR CONSOLIDATED INDEPENDENT SCHOOL DISTRICT
TAX COLLECTION REPORT
AS OF DECEMBER 31, 2017**

Exhibit E

SCHOOL YEAR TAX YEAR	2012-13 2012	2013-14 2013	2014-15 2014	2015-16 2015	2016-17 2016	2017-18 2017
COLLECTION YEAR						
1 Orig. Levy	\$ 136,145,655	\$ 142,546,726	\$ 153,118,133	\$ 173,016,530	\$ 190,749,742	\$ 206,293,212
1 Collections	\$ 140,561,034	\$ 148,220,912	\$ 160,220,428	\$ 178,028,558	\$ 195,553,464	\$ 108,107,859
Adj. To Roll	\$ 5,652,043	\$ 6,929,880	\$ 8,680,375	\$ 6,473,810	\$ 6,618,386	\$ 4,237,449
2 Collections	\$ 739,542	\$ 739,176	\$ 1,201,706	\$ 745,585	\$ 499,157	
Adj. To Roll	\$ 65,612	\$ 242,601	\$ 165,920	\$ (149,323)	\$ 15,285	
3 Collections	\$ 315,459	\$ 333,212	\$ 305,374	\$ 27,373		
Adj. To Roll	\$ 445,748	\$ (49,699)	\$ 102,657	\$ 18,623		
4 Collections	\$ 252,058	\$ 211,870	\$ 20,396			
Adj. To Roll	\$ (88,980)	\$ 113,341	\$ 77,626			
5 Collections	\$ 225,311	\$ 9,766				
Adj. To Roll	\$ 138,805	\$ 77,390				
6 Collections	\$ 43,230					
Adj. To Roll	\$ 80,624					
TOTAL:						
COLLECTIONS	\$ 142,136,634	\$ 149,514,936	\$ 161,747,903	\$ 178,801,515	\$ 196,052,622	\$ 108,107,859
ADJUSTED TAX ROLL	\$ 142,439,507	\$ 149,860,240	\$ 162,144,711	\$ 179,359,640	\$ 197,383,413	\$ 210,530,661
BALANCE TO BE COLLECTED	\$ 302,873	\$ 345,303	\$ 396,808	\$ 558,125	\$ 1,330,791	\$ 102,422,802
ADJ. TAXABLE VALUE	\$ 10,247,077,978	\$ 10,780,924,397	\$ 11,664,667,517	\$ 12,903,107,113	\$ 14,199,734,768	\$ 15,145,545,894
TOTAL % COLLECTIONS AS OF DECEMBER 31, 2017	99.8%	99.8%	99.8%	99.7%	99.3%	51.4%
TAX RATE	1.39005	1.39005	1.39005	1.39005	1.39005	1.39005

INFORMATION ITEM: PAYMENTS FOR CONSTRUCTION PROJECTS

Below is a list of invoices that have been approved for payment.

BLS Construction (Ag Barn #2)	Application # 10	\$	30,001.95
C.A. Walker Construction (Support Services Center)	Application # 4	\$	521,899.89
C.A. Walker Construction (Support Services Center)	Application # 5	\$	1,032,727.49
Drymalla Construction (Carter ES)	Application # 6	\$	1,154,077.10
Gamma Construction (Bentley ES)	Application # 18A	\$	100,000.00
IKLO Construction (Lamar CHS Band Hall)	Application # 3A	\$	187,245.00
IKLO Construction (Terry HS Band Hall)	Application # 3B	\$	175,750.00
Johnson Controls (Various campuses HVAC)	Application # 4	\$	3,856.35
Micro Integration (Ag Barn #2)	Application # 1	\$	5,722.20
Millis Construction (Terry HS Baseball/Softball Complex)	Application # 5	\$	687,887.88
Millis Construction (Terry HS Baseball/Softball Complex)	Application # 6	\$	345,310.75
PBK Architects (Bentley ES – Reimbursables)	Application # 12	\$	2,000.00
PBK Architects (Foster HS Natatorium)	Application # 11	\$	8,580.00

PBK Architects (Fulshear HS Natatorium)	Application # 11	\$	5,005.00
PBK Architects (Fulshear HS Shell Space)	Application # 4	\$	3,580.53
PBK Architects (George Ranch HS Natatorium)	Application # 11	\$	7,007.00
PBK Architects (Roberts MS)	Application # 5	\$	21,208.79
PBK Architects (Support Services -- Reimbursables)	Application # 4	\$	647.58
PBK Architects (Terry HS Baseball/Softball Complex)	Application # 9	\$	1,536.00
Raba Kistner (Campbell ES -- Running Track)	Application # 2	\$	4,206.40
Raba Kistner (Dickinson ES -- Playing Field)	Application # 2	\$	5,986.25
Raba Kistner (Fulshear HS Natatorium)	Application # 3	\$	3,041.25
Terracon (Carter ES)	Application # 6	\$	7,073.50
Terracon (Carter ES)	Application # 7	\$	482.50
Terracon (Lamar CHS Band Hall)	Application # 6	\$	593.75
Terracon (Support Services Center)	Application # 5	\$	11,669.50
Terracon (Terry HS Band Hall)	Application # 5	\$	1,568.00
Terracon (Terry HS Baseball & Softball)	Application # 6	\$	3,570.75

Turner Construction (Foster HS Natatorium)	Application # 4	\$	769,266.30
Turner Construction (Fulshear HS Natatorium)	Application # 4	\$	939,963.73
Turner Construction (George Ranch HS Natatorium)	Application # 4	\$	792,704.23
VLK Architects (Ag Barn #2)	Application # 10	\$	5,231.37
VLK Architects (Ag Barn #2)	Application # 11	\$	9,482.05
Winning Way Services (Foster HS Natatorium)	Application # 1	\$	700.00
Winning Way Services (Fulshear HS Natatorium)	Application # 1	\$	700.00
Winning Way Services (George Ranch HS Natatorium)	Application # 1	\$	700.00

Resource person: Kevin McKeever, Administrator for Operations

**11.A.#5. – PLANNING
BOARD REPORT
JANUARY 16, 2018**

EXECUTIVE SUMMARY

Bond Sale 1	Current Budget	Committed	Projected Commitments	Actuals Paid	Estimated Cost at Completion
Carl Briscoe Bentley Elementary (#24)	22,010,055.00	21,668,081.60	341,973.40	21,290,048.49	22,010,055.00
Kathleen Joerger Lindsey Elementary (#25)	23,770,861.00	21,993,760.65	1,777,100.35	20,210,216.03	23,770,861.00
Don Carter Elementary School (#26)	24,959,404.00	22,651,740.50	2,307,663.50	9,459,692.27	24,959,404.00
FHS Baseball	40,000.00	29,250.00	10,750.00	29,250.00	40,000.00
FHS Water Plant	990,000.00	708,150.00	281,850.00	116,880.00	990,000.00
HVAC Web Controls	1,056,000.00	539,600.00	516,400.00	442,242.92	1,056,000.00
LCHS Band Hall	700,000.00	642,371.50	57,628.50	434,221.34	700,000.00
Pink Elementary- Foundation	1,056,000.00	1,055,794.57	205.43	1,030,564.39	1,056,000.00
Natorium - Foster High School	8,648,880.00	8,541,215.00	107,665.00	2,419,846.68	8,648,880.00
Natorium - Fulshear High School	8,832,167.00	8,619,868.00	212,299.00	2,920,894.37	8,832,167.00
Natorium - George Ranch High School	9,086,569.00	8,936,366.00	150,203.00	2,906,171.27	9,086,569.00
Support Services Center	12,146,000.00	11,294,050.00	851,950.00	3,013,439.71	12,146,000.00
THS Band Hall	700,000.00	659,835.00	40,165.00	401,806.31	700,000.00
*THS Baseball	2,400,000.00	2,311,628.00	88,372.00	2,033,230.94	2,400,000.00
Sub Total - Bond Sale 1	116,395,936.00	109,651,710.82	6,744,225.18	66,708,504.72	116,395,936.00
Bond Sale 2					
Thomas R. Culver, III Elementary School	24,959,404.00	1,686,890.00	23,272,514.00	845,590.24	24,959,404.00
Fletcher Morgan Elementary School	26,207,374.00	1,002,385.00	25,204,989.00	425,000.00	26,207,374.00
James W. Roberts Middle School	22,342,493.00	1,454,170.00	20,888,323.00	635,220.52	22,342,493.00
Fulshear HS Shell	3,849,077.00	269,890.00	3,579,187.00	42,966.44	3,849,077.00
Satellite Ag Barn	3,786,750.00	189,000.00	3,597,750.00	0.00	3,786,750.00
Sub Total - Bond Sale 2	81,145,098.00	4,602,335.00	76,542,763.00	1,948,777.20	81,145,098.00
Grand Total	197,541,034.00	114,254,045.82	83,286,988.18	68,657,281.92	197,541,034.00

Additional Projects	Current Budget	Committed	Projected Commitments	Actuals Paid	Estimated Cost at Completion
Access Controls	800,000.00	40,200.00	759,800.00	21,105.00	800,000.00
Huggins Elementary School	700,000.00	656,442.48	43,557.52	648,178.55	700,000.00
Chiller Replacement	1,200,000.00	1,027,572.50	172,427.50	1,022,188.27	1,200,000.00
Site Lighting	1,600,000.00	91,700.15	1,508,299.85	67,261.99	1,600,000.00
Grand Total	4,300,000.00	1,815,915.13	2,484,084.87	1,758,733.81	4,300,000.00

PROGRAM OVERVIEW

Vanir | Rice & Gardner, A Joint Venture, is serving as the Program Manager for the 2014 Bond Program for Lamar CISD. In this role, we manage individual projects, and coordinate with architects and contractors. We are the liaison between LCISD Administration, Departments, and Schools and coordinate all activities necessary to complete each project.

We also provide program-wide oversight and look for efficiencies, cost reduction, and quality assurance opportunities.

Accomplishments This Month:

- Completed the design of Roberts Middle School.
- Completed the design of Culver Elementary School.

DON CARTER ELEMENTARY SCHOOL



DON CARTER ELEMENTARY SCHOOL



SCHEDULE MILESTONES:

- Current Phase: Construction
- Construction Start: May 30, 2017
- Construction Completion: July 21, 2018

OVERVIEW:

- Construction is 32% complete.
- Underground utility work is progressing for CenterPoint electric connection.
- Structural steel erection is 95% complete.
- Roofing is complete at areas A, B, and E.
- Exterior wall frame progressing.
- Electrical wiring has begun in area A, B, & E.
- Windows installed at areas A, B, C, & E.

THOMAS R. CULVER III ELEMENTARY SCHOOL



SCHEDULE MILESTONES:

- Current Phase: Construction Documents
- Construction Start: 2nd Quarter 2018
- Construction Completion: 3rd Quarter 2019

OVERVIEW:

- Culver Elementary School site is in the Briarwood Crossings subdivision in the Village of Pleak.
- The developer is clearing and grading on this section of the subdivision.
- Plan to issue for bids in January 2018.

ROBERTS MIDDLE SCHOOL



SCHEDULE MILESTONES

- Current Phase: Construction Documents
- Construction Start: 2nd Quarter 2018
- Construction Completion: 3rd Quarter 2019

OVERVIEW

- Site is on the south side of the Fulshear High School campus.
- Construction documents underway.
- Plan to issue for bids in January 2018.

FULSHEAR HIGH SCHOOL SHELL SPACE

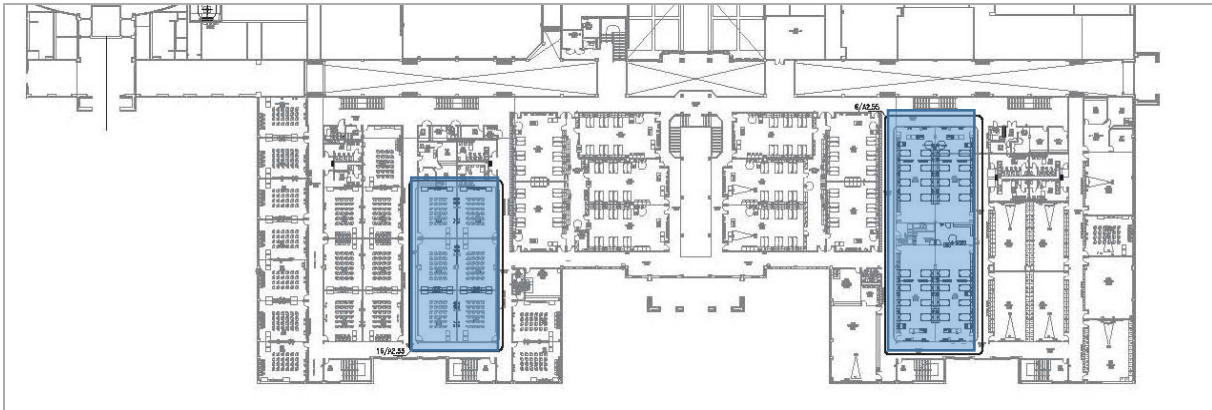

SCHEDULE MILESTONES:

- Current Phase: Construction Documents
- Construction Start: May 2018
- Construction Completion: August 2018

OVERVIEW:

- Construct interior classroom walls and room finishes.
- Construction documents are underway.
- Plan to issue for bids in January 2018.

SUPPORT SERVICES FACILITIES

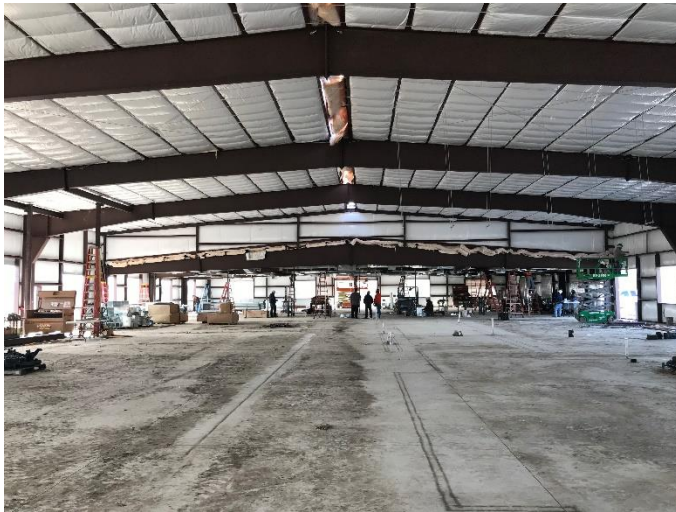

SCHEDULE MILESTONES:

Maintenance & Operations Building

- Current Phase: Construction
- Construction Start: May 30, 2017
- Construction Completion: March 2018

Support Services Facility

- Construction Start: March 2018
- Construction Completion: September 2018

OVERVIEW:

Maintenance & Operations Building

- Construction is 37% complete.
- Site utility work is complete.
- Structural concrete foundation is complete.
- Roof and wall panels are 85% complete.
- Parking and drives are 60% complete.
- Installing Electrical, Mechanical, and Plumbing in the office area.

BAND HALL ADDITIONS



Terry High School

SCHEDULE MILESTONES:

- Current Phase: Construction
- Construction Start: 2nd Quarter 2017
- Construction Completion: January 2018



Lamar Consolidated High School

OVERVIEW:

- Lamar CHS brick veneer is complete.
- Terry HS block veneer is underway.
- Lamar CHS and Terry HS:
 - HVAC, electrical, interior finishes, and fire sprinklers being installed.

BASEBALL COMPLEX RENOVATIONS

Terry High School



SCHEDULE MILESTONES:

- Current Phase: Construction
- Construction Start: 3rd Quarter 2017
- Construction Completion: January 2018



OVERVIEW:

- Concession building construction is 80% complete.
- Bleachers and press boxes are complete.
- Dugouts are 80% complete.
- Site paving is 75% complete.
- Site fencing is 90% complete.

NATATORIUMS

Foster High School | Fulshear High School | George Ranch High School



George Ranch High School



Foster High School



Fulshear High School



SCHEDULE MILESTONES:

- Current Phase: Construction
- Construction Start: 3rd Quarter 2017
- Construction Completion: 3rd Quarter 2018

OVERVIEW:

- Pool walls poured and steel erected at George Ranch High School.
- Pool walls poured and steel erected at Fulshear High School.
- Pool floor poured at Foster High School.

FOSTER HIGH SCHOOL WATER PLANT UPGRADES



SCHEDULE OVERVIEW:

- Current Phase: Construction
- Construction Start: 4th Quarter 2017
- Construction Completion: 2nd Quarter 2018

OVERVIEW:

- General Contractor is mobilizing on site.
- Drilling for water well to begin January 2018.

HVAC WEB-BASED CONTROLS

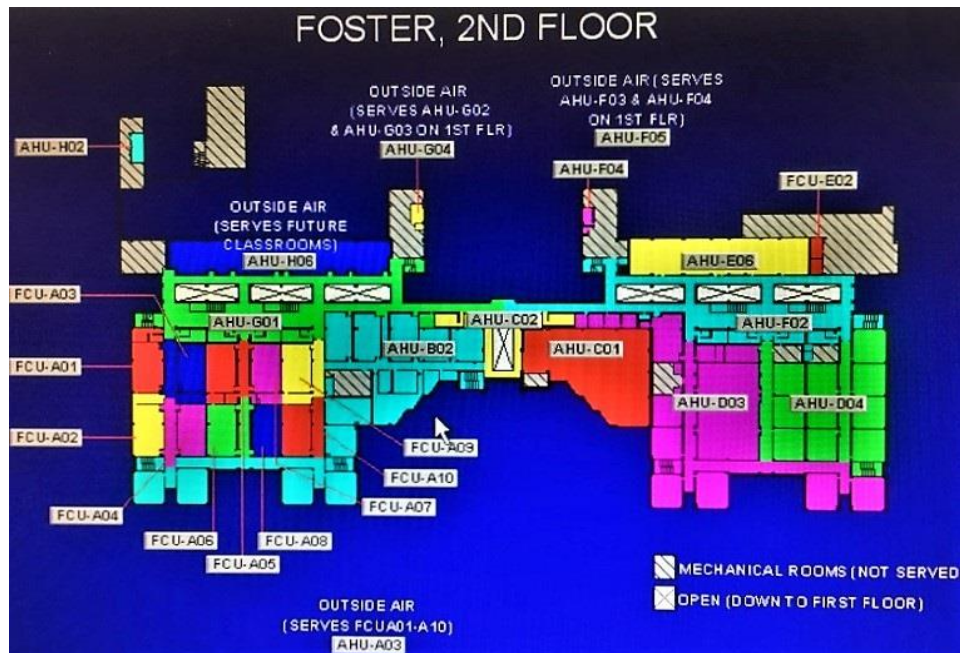

SCHEDULE OVERVIEW:

- Current Phase: Construction
- Construction Start: July 18, 2017
- Construction Completion: January 2018

OVERVIEW:

- Foster High School and Field House controls are complete.
- Briscoe Junior High and Central Plant controls are complete.
- Campbell ES, Frost ES, and Pink ES controls are complete.
- Wessendorff MS controls are complete.
- Currently working on HVAC graphics for LCISD.

ACCESS CONTROLS



SCHEDULE OVERVIEW:

- Current Phase: Construction
- Construction Start: 4th Quarter 2017
- Construction Completion: 2nd Quarter 2018

OVERVIEW:

- Contract has been awarded.
 - Cable installation has started in secondary schools.
 - Mock-up of the Access Control system will begin at one school to confirm installation process.
-

SITE LIGHTING



SCHEDULE OVERVIEW:

- Current Phase: Construction
- Construction Start: 4th Quarter 2017
- Construction Completion: 2nd Quarter 2018

OVERVIEW:

- Submittals have been reviewed and approved.
 - Fixtures have been ordered.
 - Installation of wall packs has started at selected facilities.
-

SATELLITE AG BARN #3

SCHEDULE MILESTONES:

- Current Phase: Program Development
- Construction Start: Pending Site Selection

OVERVIEW:

- Satellite Ag Barn #2 and #3 have been programmed together.
- A site for the Satellite Ag Barn #3 has not been selected.
- Project is on hold until a site has been identified.

FUTURE PROJECTS

OVERVIEW:

- 2014 Bond Sale 2 Remaining Project:
 - Morgan Elementary #28.

COMPLETED PROJECTS

Foster High School Baseball Scoreboard
Huggins Elementary School New Parent Drive
New Lindsey Elementary School
Pink Elementary School Repairs
Chiller Replacement at six schools

Completed March 2016
Completed May 2017
Completed October 2017
Completed November 2017
Completed November 2017

INFORMATION ITEM: PROJECTS FUNDED BY 2011 AVAILABLE BOND FUNDS

The list below are projects that the Board has approved to move forward with 2011 available funds:

DISTRICT FENCE PROJECT:

CSP #37-2016ML was approved at the September 2016 Regular Board Meeting. This project is now complete.

Project Budget \$450,000

CHILLER REPLACEMENT PROJECT:

VANIR Rice & Gardner are managing this project. Estes, McClure and Associates were approved at the September 2016 Regular Board Meeting. CSP 03-2017VRG was Board approved in November 2016 to American Mechanical Services. The chillers have been installed and punch list is complete

Project budget \$1,200,000

PARKING LOT LIGHTING RETROFIT:

VANIR Rice & Gardner are managing this project. Siemens has been awarded this project and contracts have been completed. Notice to proceed has been issued. Installation has begun.

Project Budget \$1,600,000

HUGGINS PARKING AND PARENT DROPOFF:

VANIR Rice & Gardner are managing this project. This project is complete. Substantial Completion was January 17th. Final payment was approved at the May Board Meeting.

Project Budget \$700,000

ACCESS CONTROL PROJECT:

VANIR Rice & Gardner are managing this project. KCI Technology has completed final documents and RF Quotes have been received. Bowie Elementary School installation has started.

Access Control Budget \$800,000

TERRY HIGH BASEBALL PROJECT:

This project is a 2014 Bond project managed by VANIR Rice & Gardner Notice to proceed as been sent and the project is under construction. The stadium seats have been installed. This project is near competition.

Additional Budget of \$1,425,000

TOTAL BUDGET FOR AVAILABLE FUND PROJECTS = \$6,175,000

Resource Person: Kevin McKeever, Administrator for Operations

INFORMATION ITEM: TRANSPORTATION UPDATE

PERSONNEL CHANGES

The following changes took place during the month:

Trainees hired:	2
Drivers leaving department	3
Full time drivers hired:	3
Drivers waiting driving test	7
Bus aides hired:	3

Hiring Incentives Paid	Employee	Referrer
Initial	5	2
Six Month	4	2

ACCIDENTS

We had the following on the road accidents during the month

<u>Date</u>	<u>Bus #</u>	<u>Action</u>	<u>Location</u>	<u>Preventable</u>	<u>Experience</u>
12/06/2017	234	Tail swing hit another parked bus	GRHS bus ramp	Preventable	3 years
12/07/2017	423	Car backed into the bus	GRHS	Non	15 years
12/13/2017	425	Car ran into back of bus	FM359EB at FM1463	Non	12 years

ROUTING AND SCHEDULING

We have the following routes in operation

R O U T I N G						
TRACK	REG	SPED	MIDDAY	DISTRICT VANS	ALC	NUMBER OF DISPLACED STUDENTS
BLUE	29	10	9	2		56
RED	44	7	10	2		59
GOLD	26	13	14	1	1	42
MAROON	50	6	8			36
PURPLE	20	2	4	1	3	11
TOTAL	169	38	45	6	4	204

TRAINING AND OTHER EVENTS

Monthly training events continued for all drivers and aides by track. Sessions were also held for flex drivers and BOSs (Bus Operations Specialists). Christmas lunches were held at both facilities during the week before Thanksgiving.

Field Trips

Site	Number of Trips	Bus Miles	Sped Bus Miles	Truck Miles	White Fleet Miles
Rosenberg	254	9,412	136	0	379
Fulshear	137	9,973	190	1080	0

STUDENT DISCIPLINE

A total of 233 discipline reports were issued this month

VEHICLE MAINTENANCE

The maintenance department responded to 8 breakdowns where the bus needed attention or replacement on the road.

The electronic fuel controller is back in service and is generating a new report, providing usage breakdown by department and product.

LAMAR CISD TRANSPORTATION

December 2017 Fuel Report

		Number of Transactions	Qty	Amount
Account : 001		VOCATIONAL		
Product :	02 #2 Diesel	4	82.100	\$141.54
Account Totals :		4	82.100	\$141.54
Account : 034		DISTRIBUTION		
Product :	01 Unleaded	31	509.500	\$846.31
Account Totals :		31	509.500	\$846.31
Account : 050		MAINTENANCE		
Product :	01 Unleaded	192	3546.400	\$5,890.58
Product :	02 #2 Diesel	51	523.900	\$903.18
Account Totals :		243	4070.300	\$6,793.76
Account : 053		TECHNICAL SERVICES		
Product :	01 Unleaded	18	252.200	\$418.90
Account Totals :		18	252.200	\$418.90
Account : 060		Transportation Rosenberg Regular		
Product :	01 Unleaded	69	1134.000	\$1,883.57
Product :	02 #2 Diesel	1086	38472.900	\$66,327.20
Account Totals :		1155	39606.900	\$68,210.77
Account : 080		SECURITY		
Product :	01 Unleaded	35	471.200	\$782.68
Account Totals :		35	471.200	\$782.68
Account : 090		ATHLETICS		
		5017 Ave I Rosenberg,Tx 77471		
Product :	01 Unleaded	3	30.500	\$50.65
Account Totals :		3	30.500	\$50.65
Account : 78		FOODSERVICE		
Product :	01 Unleaded	24	397.900	\$660.88
Account Totals :		24	397.900	\$660.88

Resource Persons: Kevin McKeever, Administrator for Operations
Mike Jones, Director of Transportation

**INFORMATION ITEM: PROPOSED BUDGET CALENDAR
FISCAL YEAR 2018 - 2019**

Attached is the proposed budget calendar for the 2018-2019 school year. This is a tentative calendar and will change if circumstances arise which would warrant modification.

Resource Person: Jill Ludwig, CPA, RTSBA, Chief Financial Officer
Yvonne Dawson, RTSBA, Budget & Treasury Officer

**ADOPTED BUDGET CALENDAR
FISCAL YEAR: 2018-19**

January 2018

Develop budget calendar
Review and file 2016-17 AFR through TSDS
Review and file 2017-18 adopted budget through TSDS
Review position control
Begin accumulating data for special allocations
Provide budget calendar for 2018-19 to Board for information

February 2018

Update and distribute budget materials to principals and budget managers at February Principals meeting.
(Follow up with budget meetings with Principals and Executive Directors)

March 2018

Refine budget assumptions
Prepare salary studies and cost projections
Develop initial revenue and expenditure projections
Assess current year budgetary status
Budgets entered into MUNIS by campuses/departments
Central Office review and evaluation of data entered by Campuses/departments
Superintendent/CFO (and other designated individuals) meet with Principals/Department Heads to discuss their budgets and instructional processes

April/May 2018

Develop preliminary Debt Service and Food Service Fund budgets
Human Resources Department to finalize staffing allocations
Receive preliminary property values from FBCAD

June 2018

Refine budgets as necessary
Review district/campus plans and alignment with preliminary expenditure budgets
Refine salary/benefit cost projections
Receive revised property values from FBCAD
Board Workshop for Budget (Session #1)

July 2018

Receive certified property tax values from FBCAD
Refine revenue/expenditure budgets (all)
Calculate estimated actual and rollback tax rates
Board Workshop for Budget (Session #2)

August 2018

Final revenue/expenditure budget adjustments
Refine all tax rate calculations
Board Workshop for Budget (Session #3)
Board Workshop for Budget (Session #4, if needed)
Budget notice/hearing/adoption (Board of Trustees)
Tax rate notice/hearing/adoption (Board of Trustees)

October 2018 – January 2019

Fort Bend County Tax Office to mail tax statements
Review and file 2017-18 AFR through TSDS
File 2018-19 adopted budget through TSDS

INFORMATION ITEM: HOLDSWORTH CENTER UPDATE

BACKGROUND INFORMATION:

The Holdsworth Center experience includes assistance from the Holdsworth District Support Team. Throughout the multi-year partnership, the support team will assist Lamar CISD in implementing an internally-aligned system for leadership development.

One of the foundational components is a defined understanding of leadership within the organization. Throughout the fall semester, 22 principals and directors worked with the Holdsworth District Support Team to define the characteristics of an outstanding leader in Lamar CISD.

Members of the steering committee will update the School Board on its progress.

Resource Persons: Valerie Vogt, Chief Academic Officer
Mike Rockwood, Executive Director of Community Relations