The logo for Lamar CISD features the word "LAMAR" in a bold, blue, sans-serif font. The letter "M" is stylized with a white sunburst pattern radiating from its center. To the right of "LAMAR" is "C|SD" in a black, sans-serif font, with a vertical bar between the "C" and "S".

LAMAR C|SD

A PROUD TRADITION | A BRIGHT FUTURE

REGULAR BOARD MEETING

Thursday, August 16, 2018

7:00 PM

James Steenbergen, President • Kay Danziger, Vice President • Kathryn Kaminski, Secretary
Mandi Bronsell • Dr. Tyson Harrell • Joe Hubenak • Melisa Roberts

**LAMAR CISD BOARD OF TRUSTEES
REGULAR BOARD MEETING
BRAZOS CROSSING ADMINISTRATION BUILDING
3911 AVENUE I, ROSENBERG, TEXAS
AUGUST 16, 2018
7:00 PM**

AGENDA

1. Call to order and establishment of a quorum
2. Opening of meeting
3. Student Reports - STEAM Camp for English Learners
4. Recognitions/awards
5. Introductions
6. Audience to patrons
7. Approval of minutes
 - A. June 19, 2018 - Special Meeting (Workshop) 7
 - B. June 21, 2018 - Regular Board Meeting 13
 - C. August 2, 2018 - Special Meeting 22
8. Board members reports
 - A. Meetings and events
9. Superintendent reports
 - A. Meetings and events
 - B. Information for immediate attention
10. **ACTION ITEMS**
 - A. **Goal: Instructional**
 1. Consider approval of the memorandum of understanding between The Houston Galveston Institute and Lamar Consolidated Independent School District 26
 2. Consider approval of out-of-state student trip requests, including, but not limited to:
 - a. Fulshear High School Band 30
 - b. Terry High School Band 31
 - B. **Goal: Planning**
 1. Consider adoption of 2018-2019 budgets 32
 2. Consider adoption, by ordinance the 2018 tax rate for the 2018-2019 school year 33
 3. Consider approval of the 2018 tax year appraisal roll and new property value 35
 4. Consider approval of the certification of 2018 tax year anticipated collection rate 49

5. Consider approval of resolution for commitment of fund balance as of August 31, 2018	51
6. Consider approval of the 2018-2019 compensation plan	53
7. Consider ratification of Quarterly Investment Report	54
8. Consider ratification of Financial and Investment Reports	61
9. Consider approval of budget amendment requests	65
10. Consider approval of Lamar CISD Investment Policy	67
11. Consider approval of the 2018-2019 service agreement with Memorial Hermann Community Benefit Corporation	100
12. Consider ratification of donations to the district, including, but not limited to:	114
a. Austin Elementary School	
b. Bentley Elementary School	
c. Campbell Elementary School	
d. Common Threads	
e. Frost Elementary School	
f. Huggins Elementary School	
g. Wertheimer Middle School	
13. Consider approval of resolution proclaiming:	
a. Childhood Cancer Awareness Month	115
b. Hispanic Heritage Month	117
14. Consider approval of nomination of candidate for positions on the Texas Association of School Boards (TASB) Board of Directors	119
15. Consider approval of CenterPoint Energy facilities extension agreement and blanket easement for Culver Elementary School	120
16. Consider approval of CenterPoint Energy facilities extension agreement for Roberts Middle School	168
17. Consider approval of amendment #5 to RFQuote #18-2016LN the HVAC full coverage maintenance and service agreement	189
18. Discussion of Board Training	193
19. Discussion of board self-assessment	194
20. Consider approval of amendment #4 to the Interlocal Cooperative contract with The Texas General Land Office	195
C. Goal: Personnel	
1. Consider approval of appraisal calendar for the 2018-2019 school year	200
2. Consider approval of new appraisers for teaching staff	202
D. Goal: Technology	
1. Consider approval of interactive flat panels hardware and installation, electrical, and project management	203
2. Consider approval of contracted services for Disaster Recovery and	211

Business Continuity Planning

11. **INFORMATION ITEMS**

A. Goal: Instructional

- 1. State of Texas Assessment of Academic Readiness (STAAR) Results - Spring 2018 213
- 2. 2018 State Accountability Ratings and Distinction Designations 228

B. Goal: Planning

- 1. Advise Texas Program 229
- 2. District Improvement Plan Quarterly Update 240
- 3. Tax Collection Report 241
- 4. Conversion and remarketing of the Series 2014A Lamar CISD Variable Rate Unlimited Tax Schoolhouse Bonds 247
- 5. Lamar CISD new money bond sales, 2017 Bond Referendum 248
- 6. Payments for Construction Projects 249
- 7. Bond Update
 - a. 2014 256
 - b. 2017 275
- 8. Projects funded by 2011 available bond funds 276
- 9. Transportation Update 277
- 10. Board policies - First Reading 280
- 11. Lamar CISD Whole Child Safety & Wellness Model 332
- 12. School Safety Update 333

12. **CLOSED SESSION**

A. Adjournment to closed session pursuant to Texas Government Code Sections 551.071, 551.072, 551.074, and 551.082, the Open Meetings Act, for the following purposes: (Time _____)

- 1. Section 551.074 - For the purpose of considering the appointment, employment, evaluation, reassignment, duties, discipline or dismissal of a public officer or employee or to hear complaints or charges against a public officer or employee. 334
 - a. Approval of personnel recommendations for employment of professional personnel
 - b. Employment of professional personnel (Information) 335
 - c. Employee resignations and retirements (Information) 340
- 2. Section 551.072 - For the purpose of discussing the purchase, exchange, lease or value of real property
 - a. Land
- 3. Section 551.071 - To meet with the District's attorney to discuss matters in which the duty of the attorney to the District under the Texas Disciplinary Rules of Professional Conduct of the State Bar of Texas clearly conflicts with the Open Meetings Act, including the grievance/complaint hearing.

- a. Any item listed on the agenda
- b. Discuss pending, threatened, or potential litigation, including school finance litigation

RECONVENE IN OPEN SESSION

Action on Closed Session Items

Future Agenda Items

Upcoming Meetings and Events

ADJOURNMENT: (Time _____)

If during the course of the meeting covered by this notice, the Board should determine that a closed session of the Board should be held or is required in relation to an item noticed in this meeting, then such closed session as authorized by Section 551.001 et seq. of the Texas Government Code (the Open Meetings Act) will be held by the Board at that date, hour or place given in this notice or as soon after the commencement of the meeting covered by this notice as the Board may conveniently meet in such closed session concerning any and all subjects and for any and all purposes permitted by Section 551.071-551.084, inclusive, of the Open Meetings Act, including, but not limited to:

Section 551.084 - For the purpose of excluding witness or witnesses from a hearing during examination of another witness.

Section 551.071 - For the purpose of a private consultation with the Board's attorney on any or all subjects or matters authorized by law.

Section 551.072 - For the purpose of discussing the purchase, exchange, lease or value of real property.

Section 551.073 - For the purpose of considering a negotiated contract for a prospective gift or donation.

Section 551.074 - For the purpose of considering the appointment, employment, evaluation, reassignment, duties, discipline or dismissal of a public officer or employee or to hear complaints or charges against a public officer or employee.

Section 551.082 - For the purpose of considering discipline of a public school child or children or to hear a complaint by an employee against another employee if the complaint or charge directly results in a need for a hearing.

Section 551.076 - To consider the deployment, or specific occasions for implementation, of security personnel or devices.

Section 551.083 - For the purpose of considering the standards, guidelines, terms or conditions the Board will follow, or instruct its representatives to follow, in consultation with representatives of employee groups in connection with consultation agreements provided for by Section 13.901 of the Texas Education Code.

Section 551.0821 – For the purpose of deliberating a matter regarding a public school student if personally identifiable information about the student will necessarily be revealed by the deliberation.

Should any final action, final decision or final vote be required in the opinion of the Board with regard to any matter considered in such closed session, then such final action, final decision or final vote shall be at either:

- a. the open meeting covered by this notice upon the reconvening of this public meeting, or
- b. at a subsequent public meeting of the Board upon notice thereof, as the Board may determine.

CERTIFICATE AS TO POSTING OR GIVING OF NOTICE

On this 10th day of August 2018 at 3:00 p.m., this notice was posted on a bulletin board located at a place convenient to the public in the central administrative offices of the Lamar Consolidated Independent School District, 3911 Avenue I, Rosenberg, Texas 77471, and in a place readily accessible to the general public at all times.

Karen Vacek

Karen Vacek
Secretary to Superintendent

Special Meeting

Be It Remembered

The State of Texas §
County of Fort Bend §
Lamar Consolidated Independent School District §

Notice of Special Meeting Held

On this the 19th day of June 2018, the Board of Trustees of the Lamar Consolidated Independent School District of Fort Bend County, Texas met in Special Session (Workshop) in Rosenberg, Fort Bend County, Texas.

1. CALL TO ORDER AND ESTABLISHMENT OF A QUORUM

This meeting was duly called to order by the President of the Board of Trustees, Mr. James Steenbergen, at 6:30 p.m.

Members Present:

James Steenbergen	President
Kay Danziger	Vice President
Kathryn Kaminski	Secretary
Mandi Bronsell	Member
Tyson Harrell	Member
Joe Hubenak	Member
Melisa Roberts	Member

Others Present:

Thomas Randle	Superintendent
Kevin McKeever	Executive Director of Facilities & Planning
Jill Ludwig	Chief Financial Officer
Leslie Haack	Deputy Superintendent of Support Services
Kathleen Bowen	Chief Human Resources Officer
Mike Rockwood	Chief of Staff
David Jacobson	Chief Technology Information Officer
Valerie Vogt	Chief Academic Officer

BUSINESS TRANSACTED

Business properly coming before the Board was transacted as follows: to witness—

2. Discussion of June 21st Regular Board Meeting Agenda Items

The Board reviewed the June 21st Regular Board Meeting agenda items.

Minutes of Special Board Meeting June 19, 2018 – page 2

9. ACTION ITEMS

9. A GOAL: INSTRUCTIONAL

9. A-1 Consider approval of the 2018-2019 agreement for prevention services

Mr. Steenbergen asked how many students participate in this. Ms. Vogt said probably between 60 and 75.

9. A-2 Consider approval of dual credit partnership agreement with Lone Star College – CyFair

Mr. Steenbergen asked if they have any scholarships available to those that need them. Ms. Vogt said they support those who need help individually.

9. A-6 Consider approval of new course of Dual Credit Psychology for the 2018-2019 school year

Ms. Roberts asked if we only get a limited amount of dual credit courses that can be offered in the high schools. Ms. Haack said the list is being expanded. Ms. Vogt said there is not a limit to the dual credit courses, it depends on the number of teachers available that have their master's degree and 18 hours in the content area. She said it can also be offered online with a teacher supervisor that works with the class. She said it is really limited to student interest and teacher availability.

9. A-8 Consider approval of an Interlocal Cooperation Agreement with Equal Opportunity Schools

Ms. Kaminski asked about the subscription that is through 2029 and the reports they want from the District. She asked why we are having a subscription to this clearing house. Ms. Vogt said in order to evaluate the student's progress, we have a data agreement to exchange their enrollment information. This allows us to use their data tools. Ms. Kaminski asked if this was a way to follow the students from freshmen year through college. Ms. Vogt said if we were to continue with them, yes. We have not had that many that have graduated out the of program yet.

9. A-9 Consider approval of the inclusive playground project

Mr. Steenbergen asked how we are funding this project. Ms. Vogt said it is funded through a grant.

Ms. Kaminski commented that typically the PTO and PTA donate money for the playground equipment. She asked if this ever been brought up so we could use that money to purchase this equipment. Ms. Vogt said not to her knowledge, this is very specialized equipment for students with physical disabilities. Ms. Kaminski asked if this is something we could talk about in the future. Ms. Vogt said she thinks the need for this type of equipment depends on the different programs that might be housed at each campus. It is rather expensive and something that is based on individual campus need. Ms. Kaminski asked if there will be a special area. Ms. Vogt said it depends on the footprint of the building and where it can be most convenient and accessible. Ms. Kaminski asked if there is a cover for this equipment. Ms. Vogt did not know but would check.

Minutes of Special Board Meeting June 19, 2018 – page 3

9. B GOAL: PLANNING

9. B-2 Consider approval of budget amendment requests

Mr. Steenberg asked about the overage charges on the managed print services. Ms. Ludwig said that is our Ricoh contract and we have terminated the contract. She said we reach this overage every year and are charged fees. We have had issues getting these bills from Ricoh and have received two bills in one year. This then caused the budget to be short.

9. B-3 Consider approval to delegate contractual authority to the Superintendent to obligate the District for Chapter 41 purposes

Mr. Steenberg asked how close are we getting to be a recaptured district. Ms. Ludwig said we are still in the gap.

9. B-5 Consider approval of phase I relating to 2017 bond projects for Transportation and Child Nutrition Departments

Ms. Kaminski asked if our future buses will have air conditioning in them. Dr. Randle said yes.

9. B-6 Consider approval of cafeteria meal price increases for 2018 - 2019

Ms. Kaminski asked why there is not a price increase for breakfast. Dr. Randle said there is a different formula dealing with the breakfast side. Mr. Hubenak asked if there has been any discussion on changing the meals if charging more for them. Ms. Haack said yes, the two new serving lines will have self-select and menu options.

9. B-7 Consider approval for expansion of Community Eligibility Provision (CEP)

Ms. Kaminski said she knows all the paperwork must be done correctly for the reimbursement for these meals. She asked if the district will be able to provide a free breakfast and lunch to all the students at that location when all the alternate paperwork is provided. Dr. Randle said that is correct. Ms. Haack said there is a pre-form that shows the students that are participating in the CEP.

9. B-10 Consider approval of purchase agreement with ISI Commercial Refrigeration, LLC for the Terry High School Food Service Line renovation

Ms. Danziger asked how this was being funded. Ms. Ludwig said in the 2017 Bond.

9. B-11 Consider approval for purchase of truck tractor for Transportation department

Ms. Roberts asked if these were the tractors that are going to be pulling the new band trailers. Dr. Randle said yes. Mr. Hubenak asked if these were new. Mr. Jones said they are new 2017 models.

9. B-13 Consider approval of an Interlocal Agreement with Region 4 Educational Service Center

Ms. Kaminski asked if Mr. McKeever is now the executive director of facilities and planning on the new restructured chart. Dr. Randle said yes. She asked if the two gentlemen are going to have titles of director of maintenance and operations and

Minutes of Special Board Meeting June 19, 2018 – page 4

assistant director of maintenance and operations, is it listed on the chart. Dr. Randle said yes, but they report to Ms. Haack. Ms. Kaminski asked about the personnel management, she is confused about their responsibilities. It says they can provide written reprimands, approval of timesheets, and absences. Then it says this agreement should not be interpreted or construed as creating or establishing the relationship of employer or employee. She said if they are reprimanding the people, aren't they working for Region 4 and under their guidance. Mr. Morgan said yes, this has been in the contract for awhile now. They work with human resources if there is disciplinary action that needs to take place. Ms. Haack said if there is disciplinary action they work with human resources who would then notify her. Region 4 reviews the timesheets, but she would have the final approval before they go to payroll.

9. B-15 Consider approval of fiber data connection for Culver Elementary School

Mr. Steenbergen asked when was the last time we did a market check on the competitiveness of Pure Speed Lightwave. Mr. Hoyt said it started with Bentley, Lindsey, Cater, and now Culver. He did not know prior to that. Mr. Jacobson said this is part of the federal eRate funding process, we went out to bid on fiber maintenance and management and lease, and it is in the second year of the bid.

9. B-16 Consider approval of additional materials testing for the Natatorium at George Ranch High School

Ms. Kaminski said she understands the contractor schedule and the weather conditions, but do we not know the number of inspections that will be needed. Mr. Hoyt said the proposals are an estimate of the required construction testing based on the architect's drawings and specifications. The testing proposal is brought to the board at the same time the construction is brought. He said they do not know who the contractor will be and do not have a detailed schedule. It is based on the testing firm's experience and that type of work and what is required.

9. B-20 Consider approval of procurement method for High School #6 and Junior High School #6

Mr. Steenbergen asked for them to explain the difference between construction manager at risk and construction manager agent. Mr. McKeever said construction manager at risk is when you go out for qualifications of a general contractor and you can look at their qualifications as well as their fee. This is a one-step process. Then that contractor is brought on during design. They help you create a guaranteed maximum price for the job. When this is approved, this is set and the job will not go over that price. A construction manager agent is more of a consultant. The district would go out for the subcontractors. This agent is used as a program manager as well. Ms. Kaminski asked if we have ever done a construction manager agent. Mr. McKeever said yes. Vanier-Rice/Garner is a construction manager agent and prior to them it was Gilbane for the program management. Mr. Steenbergen asked about the timing of selecting. Mr. McKeever said over the next three months for getting them going. Ms. Roberts asked if the district has done the construction manager at risk. Mr. McKeever said yes when we built Foster, George Ranch, and Fulshear. Ms. Roberts thought Gilbane did that. Mr. McKeever explained that Gilbane was the construction manager agent to be the program manager for the entire 2006 and 2011 bond. They did not just oversee the construction of George Ranch and Fulshear, they oversaw the construction of the entire Bond program. With this current Bond, the project managers on board will be managed in-house.

Minutes of Special Board Meeting June 19, 2018 – page 5

9. B-21 **Consider approval of CSP#14-2018LN for the roof replacement project at Seguin Early Childhood Center**

Mr. Steenbergen said he sees they are about 150k lower, but their quality of goods and services is lower than Ally Roofing and their safety record is below as well. He asked if we perceive the 150k is worth the risk. Mr. McKeever said they also looked at their capability of doing the projects.

9. B-23 **Consider approval of termination of contract and award of completion contract for band additions at Terry and Lamar Consolidated High Schools**

Mr. Steenbergen asked how much were our liquidated damages. Mr. Hoyt said \$30,000 total for being 30 days late on substantial completion. When the contractor was 60 days late and still had not completed the punch list work, is when the termination process was started. Mr. Steenbergen asked if they were not up to the task. Mr. Hoyt said they have not been up to the task the whole project. Ms. Kaminski asked if we had worked with this group before. Mr. Hoyt said they had not. She asked about the one being approved on Thursday. Mr. Hoyt said yes they have worked with them.

10. INFORMATION ITEMS

10. A GOAL: INSTRUCTIONAL

10. A-2 **Gifted and Talented Program**

Ms. Anderson gave the board an overview of the Gifted and Talented Program.

10. B GOAL: PLANNING

10. B-2 **Budget Workshop**

Jill Ludwig, Chief Financial Officer, presented Budget Workshop #1 for 2018—2019 with the following agenda:

- 2018—2019 Budget Projection
 - Types of revenue
 - Projected totals for revenue/expenditures
 - Legislative Update
 - The “Building Blocks”

3. AUDIENCE TO PATRONS

None

ADJOURNMENT TO CLOSED SESSION PURSUANT TO TEXAS GOVERNMENT CODE SECTIONS 551.071, 551.072, 551.074, and 551.082, THE OPEN MEETINGS ACT, FOR THE FOLLOWING PURPOSES:

1. Section 551.074 – For the purpose of considering the appointment, employment, evaluation, reassignment, duties, discipline or dismissal of a public officer or employee or to hear complaints or charges against a public officer or employee.
 - a. Approval of personnel recommendations for employment of professional personnel

Minutes of Special Board Meeting June 19, 2018 – page 6

- b. Employment of professional personnel (Information)
 - c. Employee resignations and retirements (Information)
 - d. Mid Year Evaluation
2. Section 551.072 – For the purpose of discussing the purchase, exchange, lease or value of real property
- a. Land
3. Section 551.071 – To meet with the District’s attorney to discuss matters in which the duty of the attorney to the District under the Texas Disciplinary Rules of Professional Conduct of the State Bar of Texas clearly conflicts with the Open Meetings Act, including the grievance/complaint hearing.
- a. Any item listed on the agenda
 - b. Discuss pending, threatened, or potential litigation, including school finance litigation

The Board adjourned to Closed Session at 8:17 p.m. for the purposes listed above.

RECONVENE IN OPEN SESSION – ACTION ON CLOSED SESSION

The Board reconvened in Open Session at 8:19 p.m.

No action taken.

ADJOURNMENT

The meeting adjourned at 8:47 p.m.

LAMAR CONSOLIDATED INDEPENDENT SCHOOL DISTRICT

Signed:

James Steenbergen
President of the Board of Trustees

Kathryn Kaminski
Secretary of the Board of Trustees

Regular Meeting

Be It Remembered

The State of Texas §
County of Fort Bend §
Lamar Consolidated Independent School District §

Notice of Regular Meeting Held

On this the 21st day of June 2018, the Board of Trustees of the Lamar Consolidated Independent School District of Fort Bend County, Texas met in Regular Session in Rosenberg, Fort Bend County, Texas.

1. CALL TO ORDER AND ESTABLISHMENT OF A QUORUM

This meeting was duly called to order by the President of the Board of Trustees, Mr. James Steenbergen, at 7:00 p.m.

Members Present:

James Steenbergen	President
Kathryn Kaminski	Vice President
Kay Danziger	Secretary
Mandi Bronsell	Member
Tyson Harrell	Member
Joe Hubenak	Member
Melisa Roberts	Member

Others Present:

Thomas Randle	Superintendent
Kevin McKeever	Executive Director of Facilities & Planning
Jill Ludwig	Chief Financial Officer
Leslie Haack	Deputy Superintendent of Support Services
Kathleen Bowen	Chief Human Resources Officer
Mike Rockwood	Chief of Staff
David Jacobson	Chief Technology Information Officer
Valerie Vogt	Chief Academic Officer
Rick Morris	Attorney

BUSINESS TRANSACTED

Business properly coming before the Board was transacted as follows: to witness—

2. OPENING OF MEETING

A moment of silence was observed and the pledge of allegiance was recited.

3. RECOGNITIONS/AWARDS

None

4. INTRODUCTIONS

Dr. Kathleen Bowen introduced new staff to the Board:
Sherry Henry, assistant principal at Beasley Elementary School
Jonathan Maxwell, executive director of student programs
Aide Pina, assistant principal at Ray Elementary School
Dallis Warren, safety coordinator

5. AUDIENCE TO PATRONS

Ms. Jen Carey addressed the Board about security and metal detectors. She was at George Ranch High School when the lockdown occurred. She feels the school is not properly secure.

Ms. Jennifer Lane addressed the Board about the operations of PTOs and booster clubs across the district. She would like to see consistencies in the bylaws and election procedures. She would like the district to implement an employee feedback system for exit interview process. She would like to see plans going forward for safety of schools.

Ms. Margie DeBose addressed the Board about safety. She said there needs to be an alert system like colleges.

6. APPROVAL OF MINUTES

A. MAY 15, 2018 SPECIAL MEETING (WORKSHOP)

It was moved by Ms. Kaminski and seconded by Ms. Roberts that the Board of Trustees approve the minutes of May 15, 2018 Special Meeting (Workshop). The motion carried unanimously.

B. MAY 17, 2018 REGULAR BOARD MEETING

It was moved by Ms. Danziger and seconded by Ms. Bronsell that the Board of Trustees approve the minutes of May 17, 2018 Regular Board Meeting. The motion carried unanimously.

7. BOARD MEMBER REPORTS

a. Meetings and Events

Ms. Danziger reported the Facilities Committee met and reported the status of projects in the District. She attended Dickinson's 25th anniversary celebration, Battle of the Bluebonnet books, graduation, TASB conference, and State of Richmond luncheon.

Mr. Hubenak reported the Technology Committee met and reported the status of projects in the District.

Mr. Steenbergen reported that he attended the Career and Technical Employer Banquet.

Ms. Kaminski reported she attended the Foster High School softball playoffs and witnessed four seniors that graduated on the field.

Minutes of Regular Board Meeting June 21, 2018 – page 9

8. SUPERINTENDENT REPORTS

- a. Meetings and Events**
- b. Information for Immediate Attention**

Dr. Randle informed the Board it was his honor to nominate the Board of Trustees for Texas Associations of School Administrators (TASA) School Honor Board for all of their hard work this year.

ACTION ITEMS FOR CONSENT OF APPROVAL: 9. A-1 – 9. A.9; 9. B-1 – 9. B-8; 9. B-10 – 9. B-23; and 9. C-1 – 9. C-2.

It was moved by Ms. Kaminski and seconded by Ms. Danziger that the Board of Trustees approve these action items as presented. The motion carried unanimously.

9. A GOAL: INSTRUCTIONAL

9. A-1 Approval of the 2018-2019 agreement for prevention services

Approved the memorandum of understanding for a Prevention Specialist to provide evidence-based substance use prevention activities at selected campuses for the 2018-2019 school year. (See inserted pages 9-A – 9-B.)

9. A-2 Approval of dual credit partnership agreement with Lone Star College - CyFair

Approved a partnership agreement with Lone Star College – CyFair for academic dual credit courses with Lamar Consolidated School District. (See inserted pages 9-C – 9-TT.)

9. A-3 Approval of Memorandum of Understanding for Texana Center and Lamar Consolidated Independent School District

Approved the memorandum of understanding for Texana Center to provide Youth Mental Health First Aid training for the LCISD faculty during the 2018-2019 school year. (See inserted pages 9-UU – 9-VV.)

9. A-4 Approval of interagency program agreement between Lamar Consolidated Independent School District and the Behavior Treatment and Training Center (BTTC), Texana Center

Approved the Interagency Program Agreement between Lamar Consolidated Independent School District and the Behavior Treatment and Training Center (BTTC), Texana Center for the 2018-2019 school year. (See inserted pages 9-WW – 9-BBB.)

9. A-5 Approval of interagency program agreement between Lamar Consolidated Independent School District and Richmond State Supported Living Center (RSSLC)

Approved the Interagency Program Agreement between Lamar Consolidated Independent School District and Richmond State Supported Living Center (RSSLC), for the 2018-2019 school year, and authorized the Superintendent to execute the agreement. (See inserted pages 9-CCC – 9-III.)

Minutes of Regular Board Meeting June 21, 2018 – page 10

9. A-6 Approval of new course of Dual Credit Psychology for the 2018-2019 school year

Approved the new course offering of Dual Credit Psychology.

9. A-7 Approval of new course of Dual Credit On Ramps Art and Entertainment Technology for the 2018-2019 school year

Approved the new course offerings of Dual Credit On Ramps Art and Entertainment Technology class.

9. A-8 Approval of an Interlocal Cooperation Agreement with Equal Opportunity Schools

Approved the Interlocal Cooperation Agreement with Equal Opportunity Schools (EOS) in the amount of \$122,000 and authorized the Superintendent to execute the agreement. (See inserted pages 10-A – 10-S.)

9. A-9 Approval of the inclusive playground project

Approved the purchase of equipment for the Inclusive Playground Project to be implemented at Hubenak, Frost, Jane Long, Williams, and Taylor Ray Elementary Schools at a cost of \$517,852.50 through the Buy Board Cooperative contract #512-16.

9. B GOAL: PLANNING

9. B-1 Ratification of Financial and Investment Reports

Ratified the Financial and Investment Reports as presented.

9. B-2 Approval of budget amendment requests

Approved the budget amendment requests as amended. (See inserted pages 10-T – 10-V.)

9. B-3 Approval to delegate contractual authority to the Superintendent to obligate the District for Chapter 41 purposes

Approved to delegate contractual authority to the Superintendent to obligate the school district under Texas Education Code (TEC) §11.1511(c)(4) as described for the 2018-19 school year. For the 2018-2019 school year, we delegated contractual authority to obligate the school district under Texas Education Code (TEC) §11.1511(c)(4) to the superintendent, solely for the purpose of obligating the district under TEC, Chapter 41, Subchapters A and D, and the rules adopted by the commissioner of education as authorized under TEC, 41.006. This included approval of the *Agreement for the Purchase of Attendance Credits or the Agreement for the Purchase of Attendance Credits (Netting Chapter 42 Funding)*.

9. B-4 Approval of resolution and revisions to accumulated leave buyback plan documents

Approved the revisions to Section 401(a) Plan documents due to changes in the Internal Revenue Code (IRC), and the related resolution. (See inserted page 10-W.)

Minutes of Regular Board Meeting June 21, 2018 – page 11

9. B-5 Approval of phase I relating to 2017 bond projects for Transportation and Child Nutrition Departments

Approved the first phase of retrofitting the current bus fleet with air conditioning and specified renovations to serving lines at Terry High School at an estimated cost of \$385,500.

9. B-6 Approval of cafeteria meal price increases for 2018 - 2019

Approved increasing meal prices for the 2018-2019 school year.

9. B-7 Approval for expansion of Community Eligibility Provision (CEP)

Approved increasing the number of campuses participating in Community Eligibility Provision (CEP) to include six (6) additional designated campuses: Lamar CHS, BF Terry HS, Lamar Junior HS, George Junior HS, Navarro Middle School, and JJ Wessendorff Middle School, pending official verification/approval by the Texas Department of Agriculture. This will bring the total number of campuses participating to sixteen (16).

9. B-8 Updates to Board Policy EIC (LOCAL) related to grade point average and class rank provisions

Approved revisions to EIC (LOCAL) to eliminate provisions related to graduates prior to the 2017-2018 school year and to increase the Grade Point Average (GPA) weight for Dual Credit courses taken by students entering 9th grade in 2018-2019 and beyond. (See inserted pages 11-A – 11-D.)

9. B-10 Approval of purchase agreement with ISI Commercial Refrigeration, LLC for the Terry High School Food Service Line renovation

Approved ISI Commercial Refrigeration, LLC for the renovation of two Terry High School kitchen serving lines in the amount of \$201,586.32. (See inserted pages 11-E – 11-G.)

9. B-11 Approval for purchase of truck tractor for Transportation department

Approved the one-time purchase of (5) truck tractors from Kyrish Truck Center in the amount of \$430,060.

9. B-12 Approval of purchase agreement for TASB Energy Cooperative Member Purchasers Fixed-Rate Transportation Fuel Program

Approved the Purchase Agreement for TASB Energy Cooperative Member Purchases Fixed-Rate Transportation Fuel Program and authorized the Superintendent to negotiate and execute the purchase agreement.

9. B-13 Approval of an Interlocal Agreement with Region 4 Educational Service Center

Approved an interlocal agreement with Region 4 Educational Service Center for facilities maintenance and operation administrative management services and authorized the Board President to execute the agreement. (See inserted pages 11-H – 11-M.)

Minutes of Regular Board Meeting June 21, 2018 – page 12

9. B-14 Approval of moving services for Carter Elementary School

Approved Roadrunner Moving & Storage for providing moving services for Carter Elementary School in the amount of \$6,750. (See inserted pages 12-A – 12-B.)

9. B-15 Approval of fiber data connection for Culver Elementary School

Approved Pure Speed Lightwave for fiber data connection for Culver Elementary School in the amount of \$53,583 and authorized the Board President to execute the agreement. (See inserted page 12-C.)

9. B-16 Approval of additional materials testing for the Natatorium at George Ranch High School

Approved Raba Kistner Consultants, Inc. for additional materials testing for the Natatorium at George Ranch High School in the amount of \$12,272 and authorized the Board President to execute the agreement. (See inserted pages 12-D – 12-F.)

9. B-17 Approval of additional materials testing for the Natatorium at Fulshear High School

Approved Raba Kistner Consultants, Inc. for additional materials testing for the Natatorium at Fulshear High School in the amount of \$11,045 and authorized the Board President to execute the agreement. (See inserted pages 12-G – 12-I.)

9. B-18 Approval of additional materials testing for the Natatorium at Foster High School

Approved Raba Kistner Consultants, Inc. for additional materials testing for the Natatorium at Foster High School in the amount of \$9,951 and authorized the Board President to execute the agreement. (See inserted pages 12-J – 12-L.)

9. B-19 Approval of deductive change order #1 and final payment for Terry High School Baseball Complex improvements

Approved the deductive change order #1 in the amount of \$683.60 and final payment of \$5,375.03 to Mills Development & Construction, LLC for the construction of the Terry High School Baseball Complex improvements and authorized the Board President to sign the change order.

9. B-20 Approval of procurement method for High School #6 and Junior High School #6

Authorized the administration to utilize Construction Manager at Risk as the construction method of procurement with the evaluation criteria for High School #6 and Junior High School #6.

9. B-21 Approval of CSP#14-2018LN for the roof replacement project at Seguin Early Childhood Center

Approved Argio Roofing for the construction of the roof replacement project at Seguin Early Childhood Center in the amount of \$926,850 and authorized the Board President to execute the agreement.

Minutes of Regular Board Meeting June 21, 2018 – page 13

9. B-22 Approval of CSP#41-2018LN for the roof replacement project at Austin Elementary School

Approved Ally Roofing Services for the construction of the roof replacement project at Austin Elementary School in the amount of \$805,251 and authorized the Board President to execute the agreement.

9. B-23 Approval of termination of contract and award of completion contract for band additions at Terry and Lamar Consolidated High Schools

Approved the termination of IKLO Construction Company on the band additions at Terry and Lamar Consolidated High Schools, approved the contract with Jamail & Smith Construction not to exceed \$100,000 to complete the contract work and authorized the Board President to execute the agreement. (See inserted pages 13-A – 13-G.)

9. C GOAL: TECHNOLOGY

9. C-1 Approval of interactive flat panels hardware and installation, electrical, and project management

Approved the purchase of Interactive Flat Panels (IFP) and installation hardware and services from Piraino Consulting Inc. in the amount of \$1,052,000; electrical work with Urbish Electrical in the amount of \$6,831; and project management services from Go IT Services according to the existing Project Management agreement estimated at \$19,000.

9. C-2 Approval for purchase of digital printing equipment

Approved ImageNet Consulting as the District's management print services vendor for hardware, software, and printer fleet support services, and authorized the Superintendent to negotiate and execute a final agreement.

9. B GOAL: PLANNING

9. B-9 Consider designation of Texas Association of School Boards delegate and alternate to the 2018 Texas Association of School Boards (TASB) Fall convention

It was moved by Ms. Roberts and seconded by Dr. Harrell that the Board of Trustees designate Kay Danziger as the delegate and Kathryn Kaminski as the alternate to the 2018 Texas Association of School Boards fall convention.

10. INFORMATION ITEMS

10. A GOAL: INSTRUCTIONAL

10. A-1 Sports Medicine Agreement with Memorial Hermann Health System

10. A-2 Gifted and Talented Program

Minutes of Regular Board Meeting June 21, 2018 – page 14

10. B GOAL: PLANNING

10. B-1 Appointment of Board Committees

	2017-2018	2018-2019
<u>STANDING COMMITTEES</u>		
POLICY REVIEW COMMITTEE	Tyson Harrell* Mandi Bronsell Kay Danziger	Tyson Harrell* Mandi Bronsell Kay Danziger
FINANCIAL AUDIT COMMITTEE	Mandi Bronsell* Joe Hubenak James Steenbergen	Mandi Bronsell* Joe Hubenak James Steenbergen
FACILITIES COMMITTEE	Kay Danziger* Joe Hubenak Kathryn Kaminski	Kay Danziger* Kathryn Kaminski James Steenbergen
ATTENDANCE BOUNDARY COMMITTEE	Melisa Roberts* Mandi Bronsell Kathryn Kaminski	Melisa Roberts* Kathryn Kaminski James Steenbergen
INFORMATION TECHNOLOGY COMMITTEE	Joe Hubenak* Kay Danziger Melisa Roberts	Joe Hubenak* Tyson Harrell Melisa Roberts

10. B-2 Budget Workshop

10. B-3 Tax Collection Report

10. B-4 Payments for Construction Projects

10. B-5 Bond Update

10. B-6 Projects funded by 2011 available bond funds

10. B-7 Transportation Update

ADJOURNMENT TO CLOSED SESSION PURSUANT TO TEXAS GOVERNMENT CODE SECTIONS 551.071, 551.072, 551.074, and 551.082, THE OPEN MEETINGS ACT, FOR THE FOLLOWING PURPOSES:

1. Section 551.074 – For the purpose of considering the appointment, employment, evaluation, reassignment, duties, discipline or dismissal of a public officer or employee or to hear complaints or charges against a public officer or employee.
 - a. Approval of personnel recommendations for employment of professional personnel
 - b. Employment of professional personnel (Information)
 - c. Employee resignations and retirements (Information)
 - d. Mid Year Evaluation
2. Section 551.072 – For the purpose of discussing the purchase, exchange, lease or value of real property
 - a. Land

Minutes of Regular Board Meeting June 21, 2018 – page 15

3. Section 551.071 – To meet with the District’s attorney to discuss matters in which the duty of the attorney to the District under the Texas Disciplinary Rules of Professional Conduct of the State Bar of Texas clearly conflicts with the Open Meetings Act, including the grievance/complaint hearing.
 - a. Any item listed on the agenda
 - b. Discuss pending, threatened, or potential litigation, including school finance litigation

The Board did not convene in Closed Session.

FUTURE AGENDA ITEMS

Wellness Model Update
Security and Communications on Texting Alert System

UPCOMING MEETINGS AND EVENTS

Special Meeting on August 2nd

ADJOURNMENT

The meeting adjourned at 7:32 p.m.

LAMAR CONSOLIDATED INDEPENDENT SCHOOL DISTRICT

Signed:

James Steenbergen
President of the Board of Trustees

Kathryn Kaminski
Secretary of the Board of Trustees

Special Meeting

Be It Remembered

The State of Texas §
County of Fort Bend §
Lamar Consolidated Independent School District §

Notice of Special Meeting Held

On this the 2nd day of August 2018, the Board of Trustees of the Lamar Consolidated Independent School District of Fort Bend County, Texas met in Special Session in Rosenberg, Fort Bend County, Texas.

1. CALL TO ORDER AND ESTABLISHMENT OF A QUORUM

This meeting was duly called to order by the President of the Board of Trustees, Mr. James Steenbergen, at 6:30 p.m.

Members Present:

James Steenbergen	President
Kay Danziger	Vice President
Kathryn Kaminski	Secretary
Tyson Harrell	Member
Joe Hubenak	Member
Melisa Roberts	Member

Members Absent:

Mandi Bronsell	Member
----------------	--------

Others Present:

Thomas Randle	Superintendent
Kevin McKeever	Executive Director of Facilities & Planning
Jill Ludwig	Chief Financial Officer
Leslie Haack	Deputy Superintendent of Support Services
Kathleen Bowen	Chief Human Resources Officer
Mike Rockwood	Chief of Staff
David Jacobson	Chief Technology Information Officer

BUSINESS TRANSACTED

Business properly coming before the Board was transacted as follows: to witness—

2. OPENING OF MEETING

A moment of silence was observed and the pledge of allegiance was recited.

3. INTRODUCTIONS

Dr. Kathleen Bowen introduced new staff to the Board:

Sara Ballard, assistant principal at Bentley Elementary School
Quantas Floyd, assistant principal at George Jr. High School
Shawna Jennings, assistant principal at George Ranch High School
Dr. Theresa Mossige, assistant superintendent of secondary education
Rachel Patterson, assistant principal at Hutchison Elementary School
Lindsey Sanders, director of community relations
Laci Crowson, assistant principal of Arredondo Elementary School
Tracey Williams, assistant principal at Fulshear High School

4. AUDIENCE TO PATRONS

Mr. Tony Hopkins congratulated the Board for being named Board of the year for Region 4. He is on the Friendswood ISD Board. He then asked for their endorsement for the TASB Board of Directors position 4C.

5. PUBLIC HEARNG – PROPOSED APPLICATION FOR OPTIONAL FLEXIBLE SCHOOL DAY PROGRAM

Dr. Theresa Mossige and Mr. Randy Donnell presented brief information on the Optional Flexible School Day Program (OFSDP). The meeting was opened at 6:41 p.m. for questions and answers. Ms. Kaminski asked if they have a goal of how many expected to graduate. Mr. Donnell said to get about 30 – 40 graduates. They would like to turn 1621 into a real alternative high school. Right now they are limited to how many students due to space. They can only have 45 students for each session. Ms. Roberts asked what is the biggest motivator to get the kids to participate. Mr. Donnell said they go to post-secondary or can get a better job. A patron in the audience asked what is the oldest student at 1621. Mr. Donnell said the oldest they have had is 23, but under the law they can take them up to 26. There being no other discussion, the public hearing closed at 6:52 p.m.

6. ACTION ITEMS

6. A GOAL: INSTRUCTIONAL

6. A-1 Approval for renewal of an Optional Flexible School Day Program

It was moved by Ms. Kaminski and seconded by Ms. Danziger that the Board of Trustees approve a continuation of the Optional Flexible School Day Program (OFSDP) that has been piloted jointly between our high schools and 1621 Place. (See inserted pages 17-A – 17-M.)

6. B GOAL: PLANNING

6. B-1 Budget Update

a. 2018 – 2019 Budget Update

Ms. Jill Ludwig, Chief Financial Officer, provided an update on the 2018 – 2019 budget with the following agenda:

- 2018 – 2019 Budget Updates for:
 - General Fund

Minutes of Special Board Meeting August 2, 2018 – page 18

- Debt Service Fund
- Child Nutrition Fund
- Truth-in-Taxation Requirements
 - Vote on Date of Meeting to Discuss Budget and Tax Rate
 - Vote on Tax Rate to be published

b. Consider approval of Date for Public Meeting to Discuss Budget and Proposed Tax Rate

It was moved by Ms. Danziger and seconded by Dr. Harrell that the Board of Trustees approve August 16, 2018 as the date for the public meeting to discuss budget and the proposed tax rate. The motion carried unanimously.

c. Consider approval of Proposed Tax Rate that will be Published in the Notice for the Public Meeting

It was moved by Ms. Danziger and seconded by Mr. Hubenak that the Board of Trustees approve the tax rate to be published in the newspaper in the Notice of Public Meeting to discuss budget and proposed tax rate.

M & O:	\$1.06000 per \$100 valuation
I & S:	\$0.33 per \$100 valuation
Total Tax Rate:	\$1.39

The motion carried unanimously.

6. B-2 Consider approval of classroom intruder latch bolt equipment installation and retrofit

It was moved by Ms. Roberts and seconded by Dr. Harrell that the Board of Trustees approve Acme Architectural Hardware for the construction of the classroom intruder latch bolt equipment and retrofit in the amount of \$390,985.72. The motion carried unanimously.

6. B-3 Consider approval of purchase agreement with ISI Commercial Refrigeration, LLC for the George Junior High School food service renovation

It was moved by Ms. Kaminski and seconded by Ms. Roberts that the Board of Trustees approve ISI Commercial Refrigeration, LLC for the renovation of a serving line in the amount of \$190,976.40. The motion carried unanimously.

ADJOURNMENT TO CLOSED SESSION PURSUANT TO TEXAS GOVERNMENT CODE SECTIONS 551.071, 551.072, 551.074, and 551.082, THE OPEN MEETINGS ACT, FOR THE FOLLOWING PURPOSES:

1. Section 551.074 – For the purpose of considering the appointment, employment, evaluation, reassignment, duties, discipline or dismissal of a public officer or employee or to hear complaints or charges against a public officer or employee.
 - a. Approval of personnel recommendations for employment of professional personnel
 - b. Employment of professional personnel (Information)
 - c. Employee resignations and retirements (Information)
2. Section 551.072 – For the purpose of discussing the purchase, exchange, lease or value of real property
 - a. Land

Minutes of Special Board Meeting August 2, 2018 – page 19

3. Section 551.071 – To meet with the District’s attorney to discuss matters in which the duty of the attorney to the District under the Texas Disciplinary Rules of Professional Conduct of the State Bar of Texas clearly conflicts with the Open Meetings Act, including the grievance/complaint hearing.
 - a. Any item listed on the agenda
 - b. Discuss pending, threatened, or potential litigation, including school finance litigation

The Board did not convene in Closed Session.

ADJOURNMENT

The meeting adjourned at 7:14 p.m.

LAMAR CONSOLIDATED INDEPENDENT SCHOOL DISTRICT

Signed:

James Steenbergen
President of the Board of Trustees

Kathryn Kaminski
Secretary of the Board of Trustees

**CONSIDER APPROVAL OF THE MEMORANDUM OF UNDERSTANDING
BETWEEN THE HOUSTON GALVESTON INSTITUTE AND
LAMAR CONSOLIDATED INDEPENDENT SCHOOL DISTRICT**

RECOMMENDATION:

That the Board of Trustees approve the memorandum of understanding between The Houston Galveston Institute (HGI Counseling) and Lamar Consolidated Independent School District for mental health services provided for students and families, and authorize the Superintendent to execute the agreement.

IMPACT/RATIONALE:

To help minimize barriers to student success through mental health support and collaboration with current community resources.

PROGRAM DESCRIPTION:

HGI will provide counseling services for all age groups of students, which may from time to time include families, or a parents' parenting group or workshops. If a need for certain age group or certain issues arises, HGI will offer group meetings for a wide range of emotional, behavioral, and interpersonal problems. These services will be offered by therapists either on site and/or online, at the schools. However, walk-in and/or emergency related services will also be available, based on therapist(s) availability. Additionally, case consultations to the onsite professionals and other psycho-educational related services will be offered. If needed or requested, HGI therapists will also be available to work with teachers and administration staff regarding burn-out, or challenges in the classroom as availability permits. The portion of matching funding from LCISD will be paid through the Title IV, federal grant monies.

Submitted by: Valerie Vogt, Chief Academic Officer
Dr. Jonathan Maxwell, Executive Director of Special Programs
Dr. Jennifer Roberts, Director of Student Support Services

Recommended for approval:

Thomas Randle

Dr. Thomas Randle
Superintendent

**SERVICE PROVIDER AGREEMENT
HOUSTON GALVESTON INSTITUTE
LAMAR CONSOLIDATED INDEPENDENT SCHOOL DISTRICT**

SCHOOL YEAR 2018-2019

The Houston Galveston Institute (HGI Counseling), a private, 501(c)3 non-profit organization, was founded in 1977 to meet the demand for mental health professionals seeking to increase their understanding of families and their skills in systems-oriented therapy with individuals, couples, families, and groups. It has distinguished itself by its unique developments in brief therapy and has been acclaimed for a Collaborative Therapy approach which emphasizes the therapeutic relationship, the role of language, narrative and conversation in therapy, the not-knowing position, and the translation of these concepts into work with difficult life situations.

Our commitment is to serve people, not the categories that they are boxed into. We recognize the importance of these categories as labels that help professionals communicate with each other; however, they are not equivalent to a person's identity. This means that we work with people/children and young adults, who are typically considered chronic treatment failures, resistant, multi-problem and difficult, or children/students facing multiple challenges that are blocking their success at school. We regard people as possessing the strengths and expertise to manage personal and professional lives in a healthy, productive manner. We work with people in respectful, cooperative partnerships to access natural resources and competencies and to develop ways to address their concerns and solve problems. At HGI, we are determined to learn from our clients: what *they* think they need; what *they* would like to accomplish; and, how *we* can best be of help.

For forty years, HGI has served clients who are underserved and underprivileged in our community, offering sliding scales and pro bono services. HGI has a reputation of training respectful, caring, culturally competent and giving professionals, and of "doing what's needed" to respond to each individual's/family's situation. It is with these common values, which HGI shares with LCISD that we look forward to a strong and effective partnership to address the mental health needs of the students and underprivileged and underserved in the Lamar CISD.

COUNSELING SERVICES

HGI will provide counseling services for all age groups of students, which may from time to time include families, or a parents' parenting group or workshops. If a need for certain age group or certain issues arise, HGI can offer group meetings for a wide range of emotional, behavioral, and interpersonal problems. These services will be offered on site, at the schools. However, walk-in and/or emergency related services will also be available, based on therapist(s) availability. HGI's Fort Bend offices are resources for these services, as needed.

Additionally, case consultations to the onsite professionals and other psycho-educational related services will be offered. If needed or requested, HGI therapists will also be available to work with teachers and administrative staff regarding burn-out or challenges in the classroom.

The following are the specific services (and service providers) that are part of the HGI-LCISD partnership for the school year 2018-2019. They are separated into three categories related to the funding.

Covered by HGI Grants

- 1) Collaboration, clinical and consultation services will be provided during non-instructional school hours on designated days for the Foster High School and George Ranch High School. The therapeutic services provided will consist of a hybrid format of tele-counseling and face-to-face counseling approximately 12 hours a week.
- 2) Lamar High School will have a designated full-time therapist(s) (bilingual preferred) to provide services five days a week. The cost will be mutually agreed upon for this contracted service and split between HGI and LCISD.
- 3) Lamar Jr. High and Wessendorf Middle will both have onsite counseling provided by one full-time counselor who will split time between the two schools. Typically, this will be 2.5 days per week, however, this counselor will be able to respond to needs that may shift the balance from time to time.

Covered by HGI and LCISD

- 4) Terry High School will have a designated full-time therapist(s) (bilingual preferred) to provide services five days a week. The cost will be mutually agreed upon for this contracted service and split between HGI and LCISD.

Covered by LCISD

- 5) Two additional schools (Navarro Middle School and George Jr. High) will be designated for counseling that will be paid for by LCISD, on a reimbursement schedule. These services will be provided by one full-time counselor who will split time between the two schools.

CLIENTS FEES AND PAYMENTS

There will be no cost to students, families, administration or teachers in need of counseling services, due to the generous support provided by LCISD and local foundations.

CLIENT CONFIDENTIALITY AND INFORMATION EXCHANGE

Confidentiality will be honored and maintained by HGI staff. All clinical records, including the session notes and intake forms, will be maintained and stored through PIMSY, HGI's online database. Upon written request, LCISD social workers or school system officials/management will be able to obtain these records from HGI with signed release of information forms. Our therapists and staff cannot answer phone calls or correspondence without first possessing the adequate documentation.

Upon the conclusion of the school year, LCISD will provide a written summary, giving narrative and other feedback, regarding the advantages and challenges that partnership with HGI provided, including suggestions for the future.

PROPOSED COST OF SERVICES

The following arrangements have been made to support the above positions/services.

HGI will absorb the cost for counseling services at Lamar High School, Foster High School, George Ranch High School, Lamar Jr. High and Wessendorf Middle School. HGI is responsible for writing, maintaining, and reporting of the grants and funds that support those schools.

HGI shares the cost of the full-time counselor at Terry High School, and pays the counselor directly, as does LCISD, for that position.

The new Red Track school position will be paid as agreed (i.e. monthly, quarterly). The full-time therapist would be an employee of HGI, and LCISD would pay HGI for this therapist at the rate of \$48,500 (total for the school year) for this position.

This includes providing scheduled or walk-in counseling sessions (students, teachers, parents, families, or specialized groups), consultations with professionals onsite, and any other educational or training services. All positions will be supported by HGI supervisors and faculty, and additional clinicians and trainers may be invited to participate in special situations and circumstances.

MOU DURATION

This project will have a proposed duration of 12 months from September 1, 2018, and can be extended with the agreement of both parties.

Dr. Sue Levin
Houston Galveston Institute
Executive Director

July 25, 2018
Date

Dr. Thomas Randle
LCISD

Date

CONSIDER APPROVAL OF OUT-OF-STATE STUDENT TRIP REQUESTS

RECOMMENDATION:

That the Board of Trustees approve out-of-state travel for the Fulshear High School Band to travel to Orlando, Florida on March 8-13, 2019.

IMPACT/RATIONALE:

The Fulshear High School Band requests to travel to Orlando, Florida on March 8 -13, 2019 by charter bus. The estimated cost for each student and chaperone will be approximately \$1,200 (based on quad occupancy). This cost includes four nights lodging, daily meals per student/chaperone, admission to the Disney and Universal theme parks, and ground transportation. All costs will be covered by individuals attending and fundraisers to be held. Ninety students are expected to participate along with three band directors and twenty-three chaperones. Dr. Erin Forbes will be the campus administrator on the trip. The Fulshear High School Band will march at one of the Disney Theme Parks as part of the Disney Magic Music Days educational performance program.

BACKGROUND INFORMATION:

This is the first out of state trip for the Fulshear High School Band.

Submitted by: Valerie Vogt, Chief Academic Officer
Dr. Terri Mossige, Assistant Superintendent of Secondary Education
Ramiro Estrada, Director of Performing and Visual Arts

Recommended for approval:



Dr. Thomas Randle
Superintendent

CONSIDER APPROVAL OF OUT-OF-STATE STUDENT TRIP REQUESTS

RECOMMENDATION:

That the Board of Trustees approve out-of-state travel for the Terry High School Band to travel to Orlando, Florida on June 9-15, 2019.

IMPACT/RATIONALE:

The Terry High School Band requests to travel to Orlando, Florida on June 9 -15, 2019 by charter bus. The estimated cost for each student and chaperone will be approximately \$1,450 (based on quad occupancy). This cost includes four nights lodging, daily meals per student/chaperone, admission to the Disney and Universal theme parks, and ground transportation. All costs will be covered by individuals attending and fundraisers to be held. One hundred-fifty students are expected to participate along with three band directors and twenty-three chaperones. Mr. Derek Johnk will be the campus administrator on the trip. The Terry High School Band will march at one of the Disney Theme Parks as part of the Disney Magic Music Days educational performance program.

BACKGROUND INFORMATION:

The Terry High School Band has previously traveled to Orlando, Florida for their band trip in 2003, 2007, 2011 and 2015.

Submitted by: Valerie Vogt, Chief Academic Officer
Dr. Terri Mossige, Assistant Superintendent of Secondary Education
Ramiro Estrada, Director of Performing and Visual Arts

Recommended for approval:



Dr. Thomas Randle
Superintendent

CONSIDER ADOPTION OF 2018-2019 BUDGETS

RECOMMENDATION:

That the Board of Trustees consider adoption of the 2018-2019 General Operating, Child Nutrition, and Debt Service Fund budgets*, at the function level, in the following amounts, as presented:

General Operating Fund	\$283,030,673.
Child Nutrition Fund	\$ 14,667,234.
Debt Service Fund	\$ 69,088,172.

*Amount subject to change as final calculations are ongoing.

IMPACT/RATIONALE:

The budgets will be presented at a Public Hearing on August 16, 2018. Budget approval is requested at the function level instead of the line item or object level.

PROGRAM DESCRIPTION:

The Texas Education Code requires school districts to prepare a budget by August 20th each year. The Texas Education Agency further requires that the budget be adopted by the Board of Trustees by August 31st of each year. Prior to adoption, notice must be given, in a newspaper published within the District, of a meeting ten (10) days prior to the date of the meeting to allow any taxpayer of the District to attend and address the Board of Trustees regarding the proposed budget. These requirements have been met.

Submitted by: Jill Ludwig, CPA, RTSBA, Chief Financial Officer
Yvonne Dawson, Director of Budget and Treasury

Recommended for approval:

Thomas Randle

Dr. Thomas Randle
Superintendent

**CONSIDER ADOPTION, BY ORDINANCE, THE 2018 TAX RATE
FOR THE 2018-2019 SCHOOL YEAR**

RECOMMENDATION:

That the Board of Trustees consider adoption, by ordinance, the 2018 tax rate.

IMPACT/RATIONALE:

A tax rate of \$1.39 (per \$100 valuation) is needed to fund the 2018-19 General Fund and Debt Service Fund budgets that are being presented to the Board of Trustees on August 16, 2018. This rate is slightly less than the current 2017 tax rate.

The Maintenance and Operations tax rate will be \$1.06 per one hundred dollars of valuation, and the Debt Service tax rate will be \$0.33 per one hundred dollars of valuation.

Submitted by: Jill Ludwig, CPA, RTSBA, Chief Financial Officer

Recommended for approval:



Dr. Thomas Randle
Superintendent

ORDINANCE SETTING TAX RATE

FOR THE TAX YEAR 2018 (SCHOOL YEAR 2018-19)

Date: August 16, 2018

On this day, we, the Board of Trustees of the Lamar Consolidated Independent School District, hereby levy or set the tax rate for the District for the tax year 2018 at a total tax rate of \$1.39 per \$100 valuation, to be assessed and collected by the duly specified assessor and collector as follows:

\$1.06 for the purpose of maintenance and operations, and

\$0.33 for the purpose of payment of principal, interest, and related costs on debts.

Such taxes are to be assessed and collected by the tax officials designated by the District.

IN CERTIFICATION THEREOF:

Signed: _____
President

Attest: _____
Secretary

Seal:

**CONSIDER APPROVAL OF 2018 TAX YEAR APPRAISAL ROLL
AND NEW PROPERTY VALUE**

RECOMMENDATION:

That the Board of Trustees consider approval of the following documents submitted by Patsy Schultz, PCC, Fort Bend County Tax Assessor/Collector:

Submission of 2018 Tax Year Appraisal Roll and New Property Value
2018 Tax Year Certified Appraisal Roll Totals and Other Certifications

PROGRAM DESCRIPTION:

Patsy Schultz, PCC, Fort Bend County Tax Assessor/Collector, requested that the above documents be recorded in the official minutes of the Lamar Consolidated Independent School District. A copy of the letter from Ms. Schultz requesting the receipt of information, as well as copies of the documents, is attached.

Submitted by: Jill Ludwig, CPA, RTSBA, Chief Financial Officer

Recommended for approval:



Dr. Thomas Randle
Superintendent



COUNTY TAX ASSESSOR / COLLECTOR
Fort Bend County, Texas

Patsy Schultz, PCC
County Tax Assessor/Collector
1317 Eugene Heimann Circle
Richmond, TX 77469-3623

(281) 341-3710
Fax (281) 341-9267
Email: patsy.schultz@fortbendcountytexas.gov
www.fortbendcountytexas.gov

**SUBMISSION OF 2018 TAX YEAR APPRAISAL ROLL
AND NEW PROPERTY VALUE**

I, Patsy Schultz, Tax Assessor Collector for Lamar CISD submit the following information from the 2018 Certified Appraisal Roll for your review:

- Taxable Value of New Property is \$ 558,021,185
- Appraised Value of All Properties is \$21,170,383,461
- Taxable Value of All Properties is \$16,240,147,029

Please record receipt of the above information into the minutes of your next meeting.



Patsy Schultz, PCC
Fort Bend County Tax Assessor/Collector



Date



FORT BEND CENTRAL APPRAISAL DISTRICT

2801 B.F. Terry Blvd. Rosenberg, Texas 77471-5600

Phone (281) 344-8623 | Fax (281) 344-8632

www.fbcad.org

Appraisal Review Board Fort Bend County, Texas

Order Approving Appraisal Records

After review of the appraisal records of the Fort Bend Central Appraisal District and hearing and determining all taxpayer protests and taxing unit challenges which were properly brought after the Appraisal Review Board in accordance with the Texas Property Tax Code, the Board, with a quorum present, has determined that the appraisal records should be approved as changed by Board orders duly filed with the Chief Appraiser.

It is therefore ordered that the appraisal records as changed are approved and constitute the appraisal roll for the Fort Bend Central Appraisal District for the tax year 2018.

The approved appraisal records are attached to the Order and are incorporated herein by reference the same as if fully copied and set forth as length.

Total Value for S01

LAMAR CISD

Total Market Value	<u>\$21,170,383,461</u>
Total Assessed Value	<u>\$18,051,770,244</u>
Total Net Taxable Value	<u>\$16,240,147,029</u>
Freeze Adjusted Taxable	<u>\$14,252,180,488</u>

Signed this 20th day of July, 2018

Thomas DeMont
Appraisal Review Board Chairman
Fort Bend County, Texas

Jo Edwards
Appraisal Review Board Secretary
Fort Bend County, Texas



FORT BEND CENTRAL APPRAISAL DISTRICT

2801 B.F. Terry Blvd. Rosenberg, Texas 77471-5600

Phone (281) 344-8623 | Fax (281) 344-8632

www.fbcad.org

**The State of Texas
County of Fort Bend**

Certification Statement:

"I, Glen Whitehead, Chief Appraiser for the Fort Bend Central Appraisal District, solemnly swear that I have made or caused to be made a diligent inquiry to ascertain all property in the district subject to appraisal by me, and that I have included in the records all property that I am aware of at an appraised value which, to the best of my knowledge and belief, was determined as required by law." The value of all property in,

S01 LAMAR CISD

as shown by the certified appraisal roll for 2018, after being submitted to and approved by the appraisal review board is:

Total Market Value	<u>\$21,170,383,461</u>
Total Assessed Value	<u>\$18,051,770,244</u>
Freeze Adjusted Taxable	<u>\$14,252,180,488</u>

Witness my hand, this 20th day of July, 2018

Glen T. Whitehead
Chief Appraiser



FORT BEND CENTRAL APPRAISAL DISTRICT

2801 B.F. Terry Blvd. Rosenberg, Texas 77471-5600

Phone (281) 344-8623 | Fax (281) 344-8632

www.fbcad.org

LIMITING CONDITIONS

The appraised value estimates provided by the district are subject to the following conditions:

1. The appraisals were prepared exclusively for ad valorem tax purposes.
2. The property characteristic data upon which the appraisals are based is assumed to be correct. Exterior inspections of the property appraised were performed as staff resources and time allowed.
3. Validation of sales transactions was attempted through questionnaires to buyer and seller, telephone survey and field review. In the absence of such confirmation, residential and commercial sales data obtained from vendors was considered reliable.
4. I have attached a list of staff providing significant mass appraisal assistance to the person signing this certification.
5. The district's latest ratio study results are available upon request.

List of staff providing significant mass appraisal assistance to the person signing this certification:

Licensed Appraiser	Licensed Appraiser	Licensed Appraiser	Licensed Appraiser
Adidi, Latisha	Fuentes, Francisco	Lewis-Paris, Lajuan	Smith, Mark
Applegate, Michael	Garcia, Amanda	Llanes, Isabel	Soliz, Crystal
Benjebbour, Tiffany	Garza, Christene	Luna, Cesar	Stark, Katie
Boettcher, Jerrica	Hall, Matthew	Manak, Kris	Stavely, Taffanie
Breaux, Joscelyne	Herrera, Jeanine	Masculine, Tiffany	Strine, Tara
Brown, Henry	Herrera, Natasha	McDaniel, Aleida	Sury, Rodney
Cariaga, Anna	Herrera, Raymond	Moncrief, Georgia	Tejeda, Sara
Castillo, Joe	Hester, Ashley	Moreno, Gilbert	Thompson, Brandon
Chanthanark, Khekie	Jackson, Lori	ODwyer, Barry	Torres, Paul
Charles, Maria	Jamail, Helen	Perkins, Clarence	Ustynik, Barry Scott
Clark, Karen	Jeronimo, Bianca	Phillips, Wayne	Vasquez, Juan Carlos
Cole, Christi	Ji, Vivian	Rangel, Cynthia	Washington, LaTonja
Cryer, David	Johnson, Tracey	Reyes, Jacob	Wharton, Charles
Deleon, Karen	Kaiser, Brooke	Roberts, Whitley	Whitehead, Glen
DeLuna, Ryan	Konesheck Doug	Rodriguez, Kimberly	Wooten, Cliff
Duran, Yvonne	Koohzad, Essie	Rubalcaba, Mandi	
Flores, Daniel	Kruse, Ben	Schlepphorst, Gary	
Fredrickson, Bo	Lee, Damian	Schweinler, Brandon	



FORT BEND CENTRAL APPRAISAL DISTRICT

2801 B.F. Terry Blvd. Rosenberg, Texas 77471-5600
Phone (281) 344-8623 | Fax (281) 344-8632
www.fbcad.org

CERTIFICATION OF 2018 APPRAISAL ROLL

FOR S01 LAMAR CISD

"I", Glen T. Whitehead, Chief Appraiser for Fort Bend Central Appraisal District, solemnly swear that the attached is that portion of the approved appraisal roll of the Fort Bend Central Appraisal District which lists property taxable by and constitutes the appraisal roll.

2018 Appraisal Roll:

Total Market Value	<u>\$21,170,383,461</u>
Total Assessed Value	<u>\$18,051,770,244</u>
Total Taxable Value	<u>\$16,240,147,029</u>
Freeze Adjusted Taxable	<u>\$14,252,180,488</u>
Number of Accounts	<u>88,459</u>



Glen T. Whitehead
Chief Appraiser

July 20th, 2018
Date



Received By

8-7-18
Date



FORT BEND CENTRAL APPRAISAL DISTRICT

2801 B.F. Terry Blvd. Rosenberg, Texas 77471-5600

Phone (281) 344-8623 | Fax (281) 344-8632

www.fbcad.org

Fort Bend County, Texas

Chief Appraisers Reasonable Estimate of Value for Property Under Review as of 2018 Appraisal Roll Certification

On July 20, 2018, the Appraisal Review Board of Fort Bend County, Texas, met to approve the appraisal records for tax year 2018. At the time of certification 98.78% of the roll value was approved leaving 1.22% of the value still under review. Under Section 29.01 of the Texas Property Tax Code the chief appraiser must give a reasonable estimate of value for the properties still under review.

For S01 the district's full certified appraised value is as follows:

Market Value	<u>\$21,170,383,461</u>
Taxable Value	<u>\$16,240,147,029</u>
Freez Taxable	<u>\$14,252,180,488</u>

A reasonable estimate of value for the properties is as follows:

Under Review	Estimated Value	Adjusted For ARB Action
Market value is	<u>\$213,854,319</u>	<u>Market Value \$203,161,603</u>
Taxable Value is	<u>\$116,648,020</u>	<u>Taxable Value \$110,815,619</u>
Freeze Adjusted Taxable	<u>\$106,720,140</u>	<u>Freeze Adjusted \$101,384,133</u>

I, the undersigned, the duly selected chief appraiser of Fort Bend Central Appraisal District, do hereby certify this to be a reasonable estimate of value of the property still under protest for 2018.

Witness my hand, this 20th day of July, 2018.

Glen T. Whitehead
Chief Appraiser

Assessment Roll Grand Totals Report

FT. BEND CENTRAL APPRAISAL DISTRICT

Tax Year: 2018 As of: Certification

S01 - Lamar CISD (ARB Approved Totals)

Number of Properties: 88459

Land Totals

Land - Homesite	(+)	\$2,454,293,477		
Land - Non Homesite	(+)	\$1,717,223,476		
Land - Ag Market	(+)	\$1,671,305,890		
Land - Timber Market	(+)	\$0		
Land - Exempt Ag/Timber Market	(+)	\$0		
Total Land Market Value	(=)	\$5,842,822,843	(+)	\$5,842,822,843

Improvement Totals

Improvements - Homesite	(+)	\$10,273,380,335		
Improvements - Non Homesite	(+)	\$3,238,093,742		
Total Improvements	(=)	\$13,511,474,077	(+)	\$13,511,474,077

Other Totals

Personal Property (5129)		\$1,809,196,901	(+)	\$1,809,196,901
Minerals (61)		\$38,700	(+)	\$38,700
Autos (276)		\$6,850,940	(+)	\$6,850,940
Total Market Value			(=)	\$21,170,383,461
Total Homestead Cap Adjustment (4500)				(-) \$90,213,303
Total Exempt Property (8195)				(-) \$1,392,956,644

Productivity Totals

Total Productivity Market (Non Exempt)	(+)	\$1,671,305,890		
Ag Use (3855)	(-)	\$35,862,620		
Timber Use (0)	(-)	\$0		
Total Productivity Loss	(=)	\$1,635,443,270	(-)	\$1,635,443,270
Total Assessed			(=)	\$18,051,770,244

Exemptions

(HS Assd 9,837,969,452)

(HS) Homestead Local (37719)	(+)	\$0		
(HS) Homestead State (37719)	(+)	\$915,536,072		
(O65) Over 65 Local (9745)	(+)	\$0		
(O65) Over 65 State (9745)	(+)	\$94,506,902		
(DP) Disabled Persons Local (712)	(+)	\$0		
(DP) Disabled Persons State (712)	(+)	\$6,630,395		
(DV) Disabled Vet (757)	(+)	\$7,633,394		
(DVX/MAS) Disabled Vet 100% (405)	(+)	\$90,085,271		
(PRO) Prorated Exempt Property (38)	(+)	\$1,134,532		
(PC) Pollution Control (9)	(+)	\$634,892,480		
(SOL) Solar (3)	(+)	\$59,670		
(HT) Historical (4)	(+)	\$13,172,925		
(AUTO) Lease Vehicles Ex (49)	(+)	\$1,102,820		
(FP) Freeport (28)	(+)	\$46,860,994		
(HB366) House Bill 366 (30)	(+)	\$7,760		
Total Exemptions	(=)	\$1,811,623,215	(-)	\$1,811,623,215
Net Taxable (Before Freeze)			(=)	\$16,240,147,029

Assessment Roll Grand Totals Report

FT. BEND CENTRAL APPRAISAL DISTRICT

Tax Year: 2018 As of: Certification

**** O65 Freeze Totals

Freeze Assessed	\$2,221,328,461
Freeze Taxable	\$1,877,416,100
Freeze Ceiling (8922)	\$20,089,209.81

**** O65 Transfer Totals

Transfer Assessed	\$44,679,880
Transfer Taxable	\$39,609,380
Post-Percent Taxable	\$29,974,496
Transfer Adjustment (150)	\$9,634,884

Freeze Adjusted Taxable (Net Taxable - Freeze Taxable - Transfer Adjustment)	(=)	\$14,353,096,045
---	------------	-------------------------

*** DP Freeze Totals

Freeze Assessed	\$127,871,175
Freeze Taxable	\$100,802,908
Freeze Ceiling (679)	\$1,116,772.82

*** DP Transfer Totals

Transfer Assessed	\$749,710
Transfer Taxable	\$644,710
Post-Percent Taxable	\$532,061
Transfer Adjustment (3)	\$112,649

Freeze Adjusted Taxable (Net Taxable - Freeze Taxable - Transfer Adjustment)	(=)	\$14,252,180,488
---	------------	-------------------------

Assessment Roll Grand Totals Report

FT. BEND CENTRAL APPRAISAL DISTRICT

Tax Year: 2018 As of: Certification

S01 - Lamar CISD (Under ARB Review Totals)

Number of Properties: 5513

Land Totals

Land - Homesite	(+)	\$11,185,690		
Land - Non Homesite	(+)	\$424,360		
Land - Ag Market	(+)	\$0		
Land - Timber Market	(+)	\$0		
Land - Exempt Ag/Timber Market	(+)	\$0		
Total Land Market Value	(=)	\$11,610,050	(+)	\$11,610,050

Improvement Totals

Improvements - Homesite	(+)	\$39,329,165		
Improvements - Non Homesite	(+)	\$135,710		
Total Improvements	(=)	\$39,464,875	(+)	\$39,464,875

Other Totals

Personal Property (282)		\$19,014,463	(+)	\$19,014,463
Minerals (4006)		\$38,266,590	(+)	\$38,266,590
Autos (1034)		\$105,498,341	(+)	\$105,498,341
Total Market Value			(=)	\$213,854,319
Total Homestead Cap Adjustment (14)				(-) \$427,920
Total Exempt Property (17)				(-) \$602,230

Productivity Totals

Total Productivity Market (Non Exempt)	(+)	\$0		
Ag Use (0)	(-)	\$0		
Timber Use (0)	(-)	\$0		
Total Productivity Loss	(=)	\$0	(-)	\$0
Total Assessed			(=)	\$212,824,169

Exemptions

(HS Assd 46,673,210)

(HS) Homestead Local (158)	(+)	\$0		
(HS) Homestead State (158)	(+)	\$3,696,001		
(O65) Over 65 Local (35)	(+)	\$0		
(O65) Over 65 State (35)	(+)	\$338,400		
(DP) Disabled Persons Local (4)	(+)	\$0		
(DP) Disabled Persons State (4)	(+)	\$25,000		
(DV) Disabled Vet (3)	(+)	\$24,500		
(AUTO) Lease Vehicles Ex (407)	(+)	\$91,830,091		
(FP) Freeport (4)	(+)	\$205,507		
(HB366) House Bill 366 (581)	(+)	\$56,650		
Total Exemptions	(=)	\$96,176,149	(-)	\$96,176,149
Net Taxable (Before Freeze)			(=)	\$116,648,020

Assessment Roll Grand Totals Report

FT. BEND CENTRAL APPRAISAL DISTRICT

Tax Year: 2018 As of: Certification

**** O65 Freeze Totals

Freeze Assessed	\$10,276,140
Freeze Taxable	\$9,373,640
Freeze Ceiling (27)	\$104,577.27

**** O65 Transfer Totals

Transfer Assessed	\$0
Transfer Taxable	\$0
Post-Percent Taxable	\$0
Transfer Adjustment (0)	\$0

Freeze Adjusted Taxable (Net Taxable - Freeze Taxable - Transfer Adjustment) (=) \$107,274,380

*** DP Freeze Totals

Freeze Assessed	\$641,740
Freeze Taxable	\$554,240
Freeze Ceiling (4)	\$7,340.86

*** DP Transfer Totals

Transfer Assessed	\$0
Transfer Taxable	\$0
Post-Percent Taxable	\$0
Transfer Adjustment (0)	\$0

Freeze Adjusted Taxable (Net Taxable - Freeze Taxable - Transfer Adjustment) (=) \$106,720,140

Effective Tax Rate Report

Tax Year: 2018

Taxing Unit: S01 - Lamar CISD

NEW EXEMPTIONS:

	COUNT	2017 ABSOLUTE EX VALUES	2018 PARTIAL EX VALUES
NEW EXEMPT PROPERTY	397	\$1,517,632	
NEW HS EXEMPTIONS	2,667		\$31,405,125
NEW PRO EXEMPTIONS	19		\$290
NEW OA EXEMPTIONS	783		\$5,018,169
NEW DP EXEMPTIONS	28		\$130,000
NEW DV1 EXEMPTIONS	15		\$82,000
NEW DV2 EXEMPTIONS	8		\$64,500
NEW DV3 EXEMPTIONS	5		\$50,000
NEW DV4 EXEMPTIONS	32		\$372,000
NEW DVX EXEMPTIONS	17		\$1,803,096
NEW HB366 EXEMPTIONS	0		\$0
NEW PC EXEMPTIONS	1		\$187,140

ABSOLUTE EX TOTAL		\$1,517,632
PARTIAL EX TOTAL	(+)	\$39,112,320
2017 TAXABLE VALUE LOST DUE TO PROPERTY BECOMING EXEMPT IN 2018	(=)	\$40,629,952

NEW ANNEXED PROPERTY:

	COUNT	APPRAISED VALUE	TAXABLE VALUE
NEWLY ANNEXED PROPERTY	0	\$0	\$0
IMPROVEMENT SEGMENTS	0	\$0	
LAND SEGMENTS	0	\$0	
MINERAL	0	\$0	
OTHER	0	\$0	

TAXABLE VALUE ON NEWLY ANNEXED PROPERTY:	\$0
--	-----

NEW AG APPLICATIONS:

NEW AG APPLICATIONS COUNT	5
2017 MARKET	\$382,210
2018 USE	(-) \$14,520
VALUE LOST DUE TO AG APPLICATIONS:	(=) \$367,690 (\$367,690 Taxable)

NEW IMPROVEMENTS:

	COUNT	TOTAL APPRAISED VALUE ¹	NEW CURRENT TAXABLE ²
NEW IMPROVEMENTS	1,501	\$362,718,015	\$277,820,078
RESIDENTIAL	1,430	\$315,759,521	\$242,624,949
COMMERCIAL	57	\$46,347,724	\$34,686,489
OTHER	14	\$610,770	\$508,640
NEW ADDITIONS	2,556	\$717,456,972	\$265,780,625

RESIDENTIAL	2,548	\$714,652,302	\$265,341,095
COMMERCIAL	3	\$2,662,370	\$323,830
OTHER	5	\$142,300	\$115,700
PERCENT COMPLETION CHANGED	16	\$1,398,740	\$397,063
TOTAL NEW PERSONAL VALUE	44	\$0	\$14,023,420
SECTION 52 & 59	0	\$0	\$0
REDUCED/EXPIRING ABATEMENTS	0	\$0	\$0
TOTALS:		\$1,081,573,727	\$558,021,185

2017 TOTAL TAXABLE (EXCLUDES UNDER PROTEST) \$15,458,553,023
2017 OA DP FROZEN TAXABLE \$1,755,386,432
2017 TAX RATE 1.3901
2017 OA DP TAX CEILING \$18,412,883

2018 CERTIFIED TAXABLE \$16,240,147,029
2018 TAXABLE UNDER PROTEST \$116,648,020
2018 OA FROZEN TAXABLE \$1,877,416,100
2018 DP FROZEN TAXABLE \$100,802,908
2018 TRANSFERRED OA FROZEN TAXABLE \$9,634,884
2018 TRANSFERRED DP FROZEN TAXABLE \$112,649
2018 OA FROZEN TAXABLE UNDER PROTEST \$9,373,640
2018 DP FROZEN TAXABLE UNDER PROTEST \$554,240
2018 TRANSFER OA WITH FROZEN TAXABLE UNDER PROTEST \$0
2018 TRANSFER DP WITH FROZEN TAXABLE UNDER PROTEST \$0
2018 APPRAISED VALUE \$18,264,594,413
2018 OA DP TAX CEILING \$21,317,901

1. Includes all land and other improvements of properties with new improvement values.
2. Includes only new improvement value.

2017 total taxable value.	1.	\$15,458,553,023
2017 tax ceilings.	2.	\$1,755,386,432
2017 total adopted tax rate.	4.	1.390050
a. 2017 M&O tax rate.	a.	1.040050
b. 2017 I&S tax rate.	+b.	0.350000
2017 taxable value of property in territory deannexed after Jan. 1, 2017.	7.	\$0
2017 taxable value lost because property first qualified for an exemption in 2018.	8.	\$40,629,952
a. Absolute exemptions.	a.	\$1,517,632
b. Partial exemptions.	+b.	\$39,112,320
2017 taxable value lost because property first qualified for agricultural appraisal (1 - d or 1 - d - 1), timber appraisal, recreational/ scenic appraisal or public access airport special appraisal in 2018.	9.	\$367,690
a. 2017 market value.	a.	\$382,210
b. 2018 productivity or special appraisal value.	-b.	\$14,520
2018 certified taxable.		\$16,240,147,029
2018 tax ceilings.	18.	\$1,987,966,541
Total 2018 taxable value of properties in territory annexed after Jan.1, 2017.	20.	\$0
Total 2018 taxable value of new improvements and new personal property	21.	\$558,021,185

* 2017 Values as of Supplement 9.

**CONSIDER APPROVAL OF THE CERTIFICATION OF 2018 TAX YEAR
ANTICIPATED COLLECTION RATE**

RECOMMENDATION:

That the Board of Trustees consider approval of the anticipated tax collection rate of 100% for the 2018 tax year.

PROGRAM DESCRIPTION:

The Texas Property Tax Code requires that the tax assessor/collector certify the anticipated tax collection rate for the upcoming year. Patsy Schultz, PCC, has certified the rate for the 2018 tax year to be 100%. A copy of her letter certifying this rate is attached.

Submitted by: Jill Ludwig, CPA, RTSBA, Chief Financial Officer

Recommended for approval:



Dr. Thomas Randle
Superintendent



COUNTY TAX ASSESSOR / COLLECTOR

Fort Bend County, Texas

Patsy Schultz, PCC
County Tax Assessor/Collector
1317 Eugene Heimann Circle
Richmond, TX 77469-3623

(281) 341-3710
Fax (281) 341-9267
Email: patsy.schultz@fortbendcountytexas.gov
www.fortbendcountytexas.gov

CERTIFICATION OF 2018 TAX YEAR ANTICIPATED COLLECTION RATE

I, Patsy Schultz, Tax Assessor Collector for
Lamar CISD

Certify that the anticipated tax collection rate for 2018 tax year for
Lamar CISD is estimated at 100%.

Please record this certification into the minutes of your next governing body meeting.

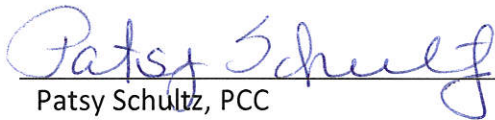

Patsy Schultz, PCC
Fort Bend County Tax Assessor/Collector



Date

**CONSIDER APPROVAL OF RESOLUTION FOR COMMITMENT
OF FUND BALANCE AS OF AUGUST 31, 2018**

RECOMMENDATION:

That the Board of Trustees approve a resolution for the commitment of fund balance, established according to the District’s fund balance policy and in compliance with GASB 54.

IMPACT/RATIONALE:

The Governmental Accounting Standards Board (GASB) issues compliance guidelines for financial reporting. GASB Statement No. 54, *Fund Balance Reporting and Governmental Fund Type Definitions (GASB 54)*, prescribes the categories and terminology used to describe the components of fund balance. Commitments and Assignments are a part of total fund balance. GASB 54 requires that the Board of Trustees formally *commit* fund balance reserves reflected in the financial statements. The Board previously delegated the authority to *assign* other fund balance reserves to the Superintendent or Chief Financial Officer.

PROGRAM DESCRIPTION:

Committed Fund Balance includes amounts constrained by the Board for a specific purpose (major maintenance fund, future land purchases, construction projects, reserves for self-funded insurance programs, etc.). Official action must be taken by the Board of Trustees to “commit” fund balance. This authority cannot be delegated. Also, formal action is needed to impose additional commitments, or modify/remove existing commitments.

The attached Resolution proposes that the following commitments are made to the fund balance of the General Fund:

- Reserves for Self-Insurance
 - Health Plan – funds as needed to cover Plan deficits
 - Workers Compensation Plan – funds as needed to cover Plan deficits
- Reserve for Child Nutrition Program - \$500,000
- Reserve for Future Land Purchases to accommodate growth - \$1,000,000
- Reserve for Transfer to Debt Service Fund for tax rate control - \$3,200,000

Submitted by: Jill Ludwig, CPA, RTSBA, Chief Financial Officer
Michele Reynolds, CPA, Director of Finance
Yvonne Dawson, Director of Budget and Treasury

Recommended for approval:



Dr. Thomas Randle
Superintendent

RESOLUTION FOR COMMITMENT OF FUND BALANCE AS OF AUGUST 31, 2018

**STATE OF TEXAS
COUNTY OF FORT BEND**

The Board of Trustees of the Lamar Consolidated Independent School District (“the District”) being convened in Regular Session within the boundaries of the Lamar Consolidated Independent School District, on the 16th day of August, 2018, designates the Superintendent or Chief Financial Officer the responsibility for assigning outstanding encumbrances as of year-end from the unassigned fund balance and hereby resolves, orders, and directs that the Lamar Consolidated Independent School District commit the following portions of its August 31, 2018 General Fund unassigned fund balance as follows:

BE IT RESOLVED, the District commits an amount to cover any outstanding deficits reflected in the Internal Service Funds for self-insured health or worker’s compensation.

BE IT RESOLVED, the District commits \$500,000 for any unforeseen deficits in the Child Nutrition Fund.

BE IT RESOLVED, the District commits \$1,000,000 for the purchase of land to accommodate growth.

BE IT RESOLVED, the District commits an amount of up to \$3,200,000 to be transferred to the Debt Service Fund of the District to support an I&S tax rate of \$0.33 per \$100 valuation for the 2018 tax year.

James Steenbergen, President
Lamar CISD Board of Trustees

Attest:

Kathryn Kaminski, Secretary
Lamar CISD Board of Trustees

CONSIDER APPROVAL OF 2018-2019 COMPENSATION PLAN

RECOMMENDATION:

That the Board of Trustees consider approval of the 2018-2019 Compensation Plan, as presented.

IMPACT/RATIONALE:

Funds will be included in the 2018-2019 budget, as per direction from the Board of Trustees, for each classification of employee outlined in the plan. The Compensation Plan reflects salary information for the 2018-2019 school year.

PROGRAM DESCRIPTION:

Each year the administration prepares the Compensation Plan for approval by the Board of Trustees. This plan represents all pay information including salary supplements and substitute pay.

Submitted by: Jill Ludwig, CPA, RTSBA, Chief Financial Officer
Dr. Kathleen Bowen, Chief Human Resources Officer

Recommended for approval:



Dr. Thomas Randle
Superintendent

**CONSIDER RATIFICATION OF QUARTERLY INVESTMENT REPORT
MARCH 2018 THROUGH MAY 2018**

RECOMMENDATION:

That the Board of Trustees ratify the quarterly investment report as submitted for the quarter ending May 31, 2018.

IMPACT/RATIONALE:

This report is required by state law and local policy CDA and includes all the pertinent information regarding the District's current investments. Investment officers for the District will be present at the meeting to answer any questions about the report and the District's cash and investment position.

Submitted by: Jill Ludwig, CPA, RTSBA, Chief Financial Officer
Yvonne Dawson, Director of Budget and Treasury
Michele Reynolds, Director of Finance

Recommended for approval:



Dr. Thomas Randle
Superintendent

**Lamar Consolidated Independent School District
Quarterly Report of Investment Activity
for the quarter ending May 31, 2018**

Preface

House Bill 2459 amended the section of the Education Code that dealt with the investment of school district funds. Code Section 2256.023 as amended requires that the Investment Officer of the District prepare and submit to the Board of Trustees a report of investment activity and position on a quarterly basis. The attached report complies, to the best of our knowledge and ability, with the requirements, and covers the period March 1, 2018 through May 31, 2018.

Investment Strategy by Fund

GENERAL FUND STRATEGY:

Investments purchased will be limited to those authorized by the District's investment policy, Board Policy CDA (Legal) and CDA (Local), and be diversified by security type and institution. To the extent possible, the District will attempt to match its investments with anticipated cash flow requirements. Investments may be made in short term securities to maintain appropriate liquidity levels, avoid market risk, and generate superior returns during periods of rising interest rates. The District will limit its maximum stated maturities to one year, unless specific authority to exceed is given by the Board of Trustees (prior to purchase). The District will determine what the appropriate average weighted maturity of the portfolio should be based on the surrounding economic climate. This determination will be made on a periodic basis, by analysis of economic data, at least annually. Investments should be purchased with the intent of holding until maturity.

Reserve funds may be invested in securities exceeding one year if the maturity of such investments is made to coincide with the expected use of the funds. The ability to invest these types of funds should be disclosed to the Board of Trustees, including appropriate time restrictions, if any exist.

DEBT SERVICE FUND STRATEGY:

The investment strategy for the Debt Service Fund is the same as that for the General Fund above, with the following exceptions. The weighted average maturity of investments for the fund may be slightly greater due to the timing of disbursements. The greatest outflow of funds occurs in February and August of each year, when bond interest and/or principal is due. Based on published debt service schedules, investments purchased will mature prior to these obligations and need for funds. Other cash requirements will be considered prior to investment.

The District does not anticipate the existence of significant reserve funds for the Debt Service Fund.

CAPITAL PROJECTS FUND STRATEGY:

Generally, the investment strategy for the Capital Projects Fund is the same as that of the General Fund. The remaining bond proceeds are currently invested in Texpool, Lone Star, MBIA Texas CLASS, TexStar and Texas Term Daily Fund Investment Pools. The yield on the funds varies with the rates for the pools as a whole. As required by law, the District will monitor the investment earnings on the bond proceeds and comply with federal arbitrage regulations.

FOOD SERVICE, WORKMEN'S COMPENSATION, HEALTH INSURANCE TRUST, AND TRUST AND AGENCY FUNDS STRATEGY:

The investment strategy for each of these funds is the same as that of the General Fund.

INVESTMENT POSITION AT MAY 31, 2018

Securities are purchased to maximize the investment earnings of the District's portfolio and to minimize idle cash balances in demand deposit accounts at the depository bank, while maintaining the liquidity required to meet currently maturing obligations such as payroll and scheduled payments for accounts payable and bonded indebtedness.

The attached report provides details of ending cash and investment balances for each of the past three months and interest earned.

COST TO FAIR MARKET VALUE COMPARISON

The cost to fair market value comparison follows in a separate section. All investable funds were deposited with authorized investment pools as of May 31, 2018. Pertinent details at May 31, 2018 of each pool in which the District had funds invested follows:

<u>POOL NAME</u>	<u>NET ASSET VALUE %</u>	<u>BOOK VALUE OF POOL</u>	<u>MARKET VALUE OF POOL</u>	<u>LCISD % OF POOL</u>
Texpool	1.00	\$19,065,860,478	\$19,064,712,440	0.6549%

The dollar weighted average maturity of the pool's portfolio for May 2018 was 28 days.

Lone Star,
Government
Overnight
Fund

1.00	\$ 3,889,300,905	\$ 3,889,337,877	0.3903%
------	------------------	------------------	---------

The dollar weighted average maturity of the portfolio for the Government Overnight Fund for May 2018 was 20 days.

<u>POOL NAME</u>	<u>NET ASSET VALUE %</u>	<u>BOOK VALUE OF POOL</u>	<u>MARKET VALUE OF POOL</u>	<u>LCISD % OF POOL</u>
MBIA, Texas CLASS	1.00	\$7,707,804,802	\$7,708,932,974	0.6221%

The dollar weighted average maturity of the portfolio for Texas CLASS Fund for May 2018 was 38 days.

Texas Term, Daily Fund	1.00	\$2,235,896,954	\$2,235,659,188	1.9788%
---------------------------	------	-----------------	-----------------	---------

The dollar weighted average maturity of the portfolio for TEXAS TERM/DAILY Fund for May 2018 was 32 days.

TexStar,	1.00	\$6,489,773,533	\$6,489,474,006	0.6933%
----------	------	-----------------	-----------------	---------

The dollar weighted average maturity of the portfolio for TEXSTAR Fund for May 2018 was 29 days.

This report includes all information required by law to be presented to the Board of Trustees on a quarterly basis. We will be pleased to present additional information in this report in the future, if requested. The District's portfolio and investment management strategy is simple and conservative, which facilitates presentation of the required information.

We hereby certify that this report is a true and accurate description of the investment portfolio of the Lamar Consolidated Independent School District for the period ending May 31, 2018. This report fully discloses all material aspects of the District's cash and investment position for the quarter then ended. All investments are in compliance with the Public Funds Investment Act (HB 2459) and local investment policy.

Submitted by:

 Jim Ludwig,
 Chief Financial Officer

Date: 8/9/18

 Yvonne Dawson
 Director of Budget & Treasury

Date: 8/9/18

 Michele Reynolds
 Director of Finance

Date: 8/9/18

LAMAR CONSOLIDATED INDEPENDENT SCHOOL DISTRICT
QUARTERLY CASH BALANCE AND INVESTMENT REPORT FOR THE PERIOD ENDING MAY 31, 2018

<u>DEMAND DEPOSIT ACCOUNT BALANCES¹</u>	<u>03/31/2018</u>	<u>04/30/2018</u>	<u>05/31/2018</u>
General Fund	2,230,375	1,249,726	1,245,106
Special Revenue Funds (Combined)	2,250,249	2,172,932	552,077
Debt Service Fund	1,349,363	1,345,863	1,343,213
Capital Projects Fund	583,561	575,990	540,528
Workmen's Compensation and Health Insurance Trust Funds	212,783	1,029,563	295,140
Trust and Agency Funds, excluding Student Activity Funds	33,570	33,570	33,570
Student Activity Funds	2,573,301	2,632,069	2,632,509
Total Demand Deposits/Cash on Hand	<u>9,233,202</u>	<u>9,039,713</u>	<u>6,642,143</u>

¹ Balances presented are reconciled balances per book and will differ slightly from actual cash balances reported in the monthly bank statements. Also, totals above include insignificant amounts of cash on hand.

LAMAR CONSOLIDATED INDEPENDENT SCHOOL DISTRICT
QUARTERLY CASH BALANCE AND INVESTMENT REPORT FOR THE PERIOD ENDING MAY 31, 2018

<u>INVESTMENT POOLS*</u>	<u>03/31/2018</u>	<u>04/30/2018</u>	<u>05/31/2018</u>
General Fund			
Texpool	120,573,542	106,024,942	91,667,024
Lone Star	2,662,006	2,665,620	2,669,478
Texas CLASS	15,713,813	15,738,950	15,766,496
Food Service Fund			
Texpool	2,552,836	2,556,341	4,261,514
Lone Star	91,941	92,065	92,199
Debt Service Fund			
Texpool	19,656,101	20,294,531	20,611,650
Lone Star	1,915,249	1,917,849	1,920,625
Texas CLASS	964,590	966,133	967,824
TexasTerm/Daily	136,974	137,159	137,364
TexSTAR	3,353,530	3,358,024	3,362,946
Capital Projects Fund			
Texpool	3,965,199	3,834,261	7,758,711
Lone Star	11,902,078	9,747,348	9,761,454
Texas CLASS	32,150,995	31,382,737	31,212,640
TexasTerm/Daily	43,982,099	44,041,719	44,107,281
TexSTAR	54,169,753	50,031,327	41,631,029
Workmen's Compensation and Health Insurance Trust Funds			
Texpool	615,671	546,428	475,326
Lone Star	732,404	733,398	734,460
Special Revenue Funds			
Texpool	54,096	54,170	54,249
Student Activity Funds			
Texpool	37,504	37,556	37,610
Total Investment in Pools	<u>315,230,381</u>	<u>294,160,558</u>	<u>277,229,880</u>
Summary of Interest Earned by Month			
Texpool	202,925	192,751	192,522
Lone Star	21,943	21,486	21,934
Texas CLASS	67,305	71,899	77,591
TexSTAR	76,612	74,615	70,424
Texas Term/Daily	55,983	59,805	65,767
Total Interest Earned from Investment Pools	<u>424,767</u>	<u>420,556</u>	<u>428,237</u>
Average Yield by Month			
Texpool	1.52	1.67	1.72
Lone Star	1.50	1.65	1.70
Texas CLASS	1.75	1.95	2.06
TexSTAR	1.50	1.63	1.73
Texas Term/Daily	1.50	1.65	1.75

* See supplemental report attached for balances at May 31, 2018 and details of transactions.

LAMAR CONSOLIDATED INDEPENDENT SCHOOL DISTRICT
 DETAILS OF TRANSACTIONS FOR INVESTMENT POOLS

INVESTMENT POOLS	03/1/2018	DEPOSITS	WITHDRAWALS	03/31/2018	DEPOSITS	WITHDRAWALS	04/30/2018	DEPOSITS	WITHDRAWALS	05/31/2018	
General Fund											
	Texpool	135,881,216	2,275,557	(18,583,232)	120,573,542	1,971,099	(16,519,698)	106,024,942	999,624	(15,357,543)	91,667,024
	Lone Star	2,656,630	3,376	-	2,662,006	3,614	-	2,665,620	3,858	-	2,669,478
	Texas CLASS	15,690,499	23,314	-	15,713,813	25,137	-	15,738,950	27,546	-	15,766,496
Food Service Fund											
	Texpool	2,549,554	3,282	-	2,552,836	3,505	-	2,556,341	1,705,173	-	4,261,514
	Lone Star	91,824	117	-	91,941	125	-	92,065	133	-	92,199
Debt Service Fund											
	Texpool	18,922,207	733,894	-	19,656,101	638,431	-	20,294,531	317,119	-	20,611,650
	Lone Star	1,912,820	2,429	-	1,915,249	2,601	-	1,917,849	2,775	-	1,920,625
	Texas CLASS	963,159	1,431	-	964,590	1,543	-	966,133	1,691	-	967,824
	Texas Term/Daily	136,800	174	-	136,974	186	-	137,159	204	-	137,364
	TexSTAR	3,348,265	4,265	-	3,353,530	4,494	-	3,358,024	4,922	-	3,362,946
Capital Projects Fund											
	Texpool	4,149,790	5,156	(189,747)	3,965,199	5,419	(136,357)	3,834,261	3,924,450	-	7,758,711
	Lone Star	11,886,985	15,093	-	11,902,078	14,152	(2,168,882)	9,747,348	14,106	-	9,761,454
	Texas CLASS	32,611,805	42,559	(503,369)	32,150,995	45,219	(813,477)	31,382,737	48,353	(218,450)	31,212,640
	Texas Term/Daily	43,926,290	55,809	-	43,982,099	59,619	-	44,041,719	65,563	-	44,107,281
	TexSTAR	58,030,347	72,346	(3,932,940)	54,169,753	70,122	(4,208,548)	50,031,328	2,190,762	(10,591,060)	41,631,029
Workmen's Compensation and Health Insurance Trust Funds											
	Texpool	431,248	1,234,423	(1,050,000)	615,671	1,420,758	(1,490,000)	546,428	1,358,898	(1,430,000)	475,326
	Lone Star	731,475	929	-	732,404	994	-	733,398	1,061	-	734,460
Special Revenue Funds											
	Texpool	54,026	70	-	54,096	74	-	54,170	79	-	54,249
Student Activity Funds											
	Texpool	37,456	48	-	37,504	51	-	37,556	55	-	37,610
Total Investment in Pools		335,015,336	4,474,271	(24,259,288)	315,230,379	4,267,142	(25,336,962)	294,160,560	10,666,373	(27,597,053)	277,229,861

CONSIDER RATIFICATION OF FINANCIAL AND INVESTMENT REPORTS

RECOMMENDATION:

That the Board of Trustees ratify the Financial and Investment Reports as presented.

PROGRAM DESCRIPTION:

Financial reporting is intended to provide information useful for many purposes. The reporting function helps fulfill government's duty to be publicly accountable, as well as to help satisfy the needs of users who rely on the reports as an important source of information for decision making.

Financial reports and statements are the end products of the accounting process. You will find attached the following reports:

- Ratification of July 2018 Disbursements, all funds
 - List of disbursements for the month by type of expenditure
- Financial Reports
 - Year-to-Date Cash Receipts and Expenditures, General Fund only
 - Investment Report

Submitted by: Jill Ludwig, CPA, RTSBA, Chief Financial Officer
Michele Reynolds, CPA, Director of Finance

Recommended for ratification:



Dr. Thomas Randle
Superintendent

SCHEDULE OF JULY 2018 DISBURSEMENTS

IMPACT/RATIONALE:

All disbursements made by the Accounting Department are submitted to the Board of Trustees for ratification on a monthly basis. Disbursements made during the month of July total \$28,843,357 and are shown below by category:

<u>3-Digit Object</u>	<u>Description</u>	<u>Disbursements</u>
611/612	Salaries and Wages, All Personnel	17,175,062
614	Employee Benefits	1,164,516
621	Professional Services	3,099
623	Education Services Center	18,212
624	Contracted Maintenance and Repair Services	542,403
625	Utilities	752,546
626	Rentals and Operating Leases	14,913
629	Miscellaneous Contracted Services	684,244
631	Supplies and Materials for Maintenance and Operations	313,253
632	Textbooks and Other Reading Materials	35,521
633	Testing Materials	114,297
634	Food Service	19,305
639	General Supplies and Materials	758,572
641	Travel and Subsistence -- Employee and Student	71,855
642	Insurance and Bonding Costs	306,534
649	Miscellaneous Operating Costs/Fees and Dues	62,944
659	Other Debt Services Fees	12,000
662	Building Purchase, Construction, and/or Improvements	5,495,572
663	Furniture & Equipment - \$5,000 or more per unit cost	376,439
129	Misc. Receivable/Alternative Certification Fees	4,975
141	Pre-paid	913,819
217	Operating Transfers, Loans and Reimbursements	674
573/575/592	Miscellaneous Refunds/Reimbursements to Campuses	2,602
	Total	28,843,357

PROGRAM DESCRIPTION:

The report above represents all expenditures made during the month of July 2018. The detailed check information is available upon request.

Submitted by,

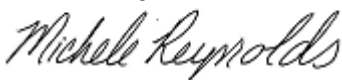

Michele Reynolds,
Director of Finance

Recommended for approval:

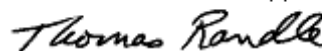

Dr. Thomas Randle
Superintendent

**LAMAR CONSOLIDATED I.S.D.
GENERAL FUND
YEAR TO DATE CASH RECEIPTS AND EXPENDITURES
(BUDGET AND ACTUAL)
AS OF JULY 31, 2018**

CASH RECEIPTS	AMENDED BUDGET	ACTUAL	BUDGET VARIANCE	PERCENT ACTUAL/ BUDGET
5700-LOCAL REVENUES	163,807,291.00	163,090,989.00	(716,302.00)	99.6%
5800-STATE PROGRAM REVENUES	99,718,336.00	75,415,148.00	(24,303,188.00)	75.6%
5900-FEDERAL PROGRAM REVENUES	3,065,000.00	3,644,490.00	579,490.00	118.9%
TOTAL- REVENUES	266,590,627.00	242,150,627.00	(24,440,000.00)	90.8%
EXPENDITURES				
6100-PAYROLL COSTS	222,014,437.00	201,593,685.00	20,420,752.00	90.8%
6200-PROFESSIONAL/CONTRACTED SVCS.	24,897,206.00	19,159,761.00	5,737,445.00	77.0%
6300-SUPPLIES AND MATERIALS	14,451,272.00	9,603,557.00	4,847,715.00	66.5%
6400-OTHER OPERATING EXPENDITURES	5,433,526.00	4,323,592.00	1,109,934.00	79.6%
6600-CAPITAL OUTLAY	4,873,977.00	3,320,189.00	1,553,788.00	68.1%
TOTAL-EXPENDITURES	271,670,418.00	238,000,784.00	33,669,634.00	87.6%

**Local Investment Pools
as of July 31, 2018**

ACCOUNT NAME	BEGINNING BALANCE	TOTAL DEPOSIT	TOTAL WITHDRAWAL	TOTAL INTEREST	MONTH END BALANCE
TexPool accounts are as follows:					
Food Service	3,967,512.61	0.00	0.00	6,367.34	3,973,879.95
General Account	73,329,750.16	10,500,000.00	23,383,231.66	105,119.32	60,551,637.82
Health Insurance	40,062.31	1,194,898.33	1,230,000.00	575.91	5,536.55
Workmen's Comp	338,515.05	38,333.33	50,000.00	562.94	327,411.32
Property Tax	10,069,374.91	796,962.34	0.00	16,935.39	10,883,272.64
Vending Contract Sponsor	293,349.42	0.00	0.00	470.82	293,820.24
Deferred Compensation	2.55	0.00	0.00	0.00	2.55
Capital Projects Series 2005	232,446.04	0.00	0.00	373.06	232,819.10
Student Activity Funds	37,664.60	0.00	0.00	60.35	37,724.95
Taylor Ray Donation Account	54.72	0.00	0.00	0.00	54.72
Capital Projects Series 2007	213,420.53	0.00	0.00	342.48	213,763.01
Common Threads Donation	54,329.47	0.00	0.00	87.24	54,416.71
Debt Service 2012A	2,092,763.92	0.00	0.00	3,358.62	2,096,122.54
Debt Service 2012B	271,991.17	0.00	0.00	436.52	272,427.69
Debt Service 2014A	384,765.14	0.00	0.00	617.50	385,382.64
Debt Service 2014B	872,667.49	0.00	0.00	1,400.54	874,068.03
Debt Service 2013	153,089.42	0.00	0.00	245.72	153,335.14
Debt Service 2013A	2,973.14	0.00	0.00	4.68	2,977.82
Debt Service 2015	3,624,239.05	0.00	0.00	5,816.45	3,630,055.50
Debt Service 2016A	1,871,715.02	0.00	0.00	3,003.85	1,874,718.87
Debt Service 2016B	495,346.01	0.00	0.00	794.99	496,141.00
Debt Service 2017	1,712,197.01	0.00	0.00	2,934.88	1,715,131.89
Debt Service 2017 Capitalized Interest	2,042,041.14	0.00	0.00	3,277.25	2,045,318.39
Capital Projects 2017	4,323,938.85	0.00	2,278,970.94	10,368.36	2,055,336.27
Debt Service 2018	4,715,594.20	3,604,861.66	0.00	8,877.41	8,329,333.27
Capital Projects 2018	0.00	90,000,000.00	0.00	32,693.67	90,032,693.67
Lone Star Investment Pool Government Overnight Fund					
Capital Projects Fund	5,123.30	0.00	0.00	8.30	5,131.60
Workers' Comp	735,557.70	0.00	0.00	1,191.83	736,749.53
Property Tax Fund	32,815.48	0.00	0.00	53.17	32,868.65
General Fund	2,640,653.51	0.00	0.00	4,278.66	2,644,932.17
Food Service Fund	92,336.00	0.00	0.00	149.61	92,485.61
Debt Service Series 1996	0.01	0.00	0.00	313.51	313.52
Capital Project Series 1998	714.93	0.00	0.00	1.16	716.09
Debt Service Series 1990	0.04	0.00	0.00	0.00	0.04
Debt Service Series 1999	2.43	0.00	0.00	0.00	2.43
Capital Project Series 1999	0.01	0.00	0.00	0.00	0.01
Capital Projects 2007	391.92	0.00	0.00	0.64	392.56
Capital Projects 2008	0.31	0.00	0.00	0.00	0.31
Capital Projects 2012A	43.75	0.00	0.00	0.07	43.82
Capital Projects 2014B	17.37	0.00	0.00	0.03	17.40
Capital Projects 2015	938.59	0.00	0.00	1.52	940.11
Debt Service Series 2015	1,923,491.12	0.00	0.00	3,116.64	1,926,607.76
Capital Projects 2017	9,768,818.87	0.00	0.00	23,655.66	9,792,474.53
Capital Projects 2018	0.00	75,000,000.00	0.00	23,560.41	75,023,560.41
Debt Service Series 2018	0.00	3,004,051.38	0.00	943.69	3,004,995.07
MBIA Texas CLASS Fund					
General Account	15,794,482.28	0.00	0.00	29,938.69	15,824,420.97
Capital Project Series 1998	930.92	0.00	0.00	1.81	932.73
Capital Projects Series 2007	1.00	0.00	0.00	0.00	1.00
Debt Service Series 2007	1.00	0.00	0.00	0.00	1.00
Capital Projects Series 2012A	6,010,896.34	0.00	0.00	11,393.76	6,022,290.10
Debt Service 2015	969,540.85	0.00	0.00	1,837.78	971,378.63
Capital Projects 2017	25,231,538.66	0.00	0.00	42,417.85	25,273,956.51
TEXSTAR					
Capital Projects Series 2007	758.30	0.00	0.00	1.24	759.54
Debt Service Series 2008	13.86	0.00	0.00	0.00	13.86
Capital Projects Series 2008	988,310.53	0.00	0.00	1,591.81	989,902.34
Debt Service Series 2012A	40.62	0.00	0.00	0.04	40.66
Debt Service Series 2012B	1.64	3,604,715.16	3,604,715.16	187.93	189.57
Capital Projects Series 2012A	12.21	0.00	0.00	0.00	12.21
Debt Service 2013	2.67	0.00	0.00	0.00	2.67
Capital Projects 2014A	0.74	90,000,000.00	90,000,000.00	4,692.06	4,692.80
Capital Projects 2014B	2.65	0.00	0.00	0.00	2.65
Debt Service 2015	3,367,947.88	0.00	0.00	5,424.52	3,373,372.40
Capital Projects 2015	12,616,088.18	0.00	6,557,302.64	17,810.83	6,076,596.37
Capital Projects 2017	24,724,815.05	0.00	0.00	39,822.41	24,764,637.46
Capital Projects 2018	0.00	90,000,000.00	0.00	32,732.37	90,032,732.37
Debt Service 2018	0.00	3,604,715.16	0.00	1,311.01	3,606,026.17
TEXAS TERM/DAILY Fund					
Capital Projects Series 2007	1,026,815.83	0.00	0.00	1,705.05	1,028,520.88
Capital Projects Series 2008	143.80	0.00	0.00	0.24	144.04
Capital Projects Series 2012A	57.75	0.00	0.00	0.10	57.85
Capital Projects Series 2014A	0.32	45,000,000.00	45,000,000.00	2,418.89	2,419.21
Capital Projects Series 2014B	2,278,705.19	0.00	0.00	3,783.85	2,282,489.04
Debt Service 2015	137,571.78	1,802,430.83	1,802,430.83	325.33	137,897.11
Capital Projects 2015	15,476,416.78	0.00	0.00	25,698.98	15,502,115.76
Capital Projects 2017	25,392,208.01	0.00	0.00	42,164.41	25,434,372.42
Capital Projects 2018	0.00	45,000,000.00	0.00	16,927.59	45,016,927.59
Debt Service 2018	0.00	1,802,430.83	0.00	678.02	1,803,108.85

ACCOUNT TYPE	AVG. RATE OF RETURN	CURRENT MONTH EARNINGS
TEXPOOL ACCOUNT INTEREST	1.89	\$204,725.29
LONE STAR ACCOUNT INTEREST	1.91	\$57,274.90
MBIA TEXAS CLASS ACCOUNT INTEREST	2.24	\$85,589.89
TEXSTAR ACCOUNT INTEREST	1.90	\$103,574.22
TEXAS TERM/DAILY ACCOUNT INTEREST	1.96	\$93,702.46
TOTAL CURRENT MONTH EARNINGS		\$544,866.76
EARNINGS 9-01-17 THRU 6-30-18		\$3,410,451.65
TOTAL CURRENT SCHOOL YEAR EARNINGS		\$3,955,318.41

CONSIDER APPROVAL OF BUDGET AMENDMENT REQUESTS

RECOMMENDATION:

That the Board of Trustees consider approval of the year-end budget amendment request.

IMPACT/RATIONALE:

The proposed budget amendments require school board approval because budgeted funds are being reallocated between functional categories and/or new budgets are being established.

PROGRAM DESCRIPTION:

Budget amendments are mandated by the state for budgeted funds reallocated from one functional level, and state and/or federal program to another. These budget changes are usually the result of unexpected levels of expenditures in certain categories and amendments are for legal compliance. Other budget amendments are determined by the School Board.

Since the operating budget for Lamar CISD is adopted at the functional level, budget revisions are required for reallocations between functional levels or when new budgets are being established. All necessary budget amendments must be formally adopted by the School Board and recorded in the Board minutes. (TEA Financial Accountability System Resource Guide, Financial Accounting & Reporting, Update 15.0)

Submitted by: Jill Ludwig, CPA, RTSBA, Chief Financial Officer
Yvonne Dawson, RTSBA, Director of Budget and Treasury
Michele Reynolds, CPA, Director of Finance

Recommended for approval:



Dr. Thomas Randle
Superintendent

The Office of the Chief Financial Officer is requesting an amendment to adjust all functional categories at year end to ensure compliance with TEA regulations (by avoiding overages at functional level).

Expenditures:

199-11	Classroom Instruction	9,958,693.00
199-12	Instr. Resources and Media Services	225,000.00
199-13	Curriculum and Instr. Staff Development	(99,700.00)
199-21	Instructional Leadership	(50,000.00)
199-23	School Leadership	1,350,170.00
199-31	Guidance, Counseling and Evaluation	(59,713.00)
199-32	Social Work Services	75,000.00
199-33	Health Services	200,000.00
199-34	Student Transportation	3,400,000.00
199-35	Child Nutrition	30,000.00
199-36	Co-curricular/Extra-curricular Activities	100,000.00
199-51	Plant Maintenance & Operations	1,000,550.00
199-52	Security & Monitoring Services	200,000.00
199-53	Data Processing Services	200,000.00
199-61	Community Services	(100,000.00)
199-81	Facilities Acquisition & Construction	200,000.00
599-00	Other-Sources Bond Transactions	12,016,059.00

CONSIDER APPROVAL OF LAMAR CISD INVESTMENT POLICY

RECOMMENDATION:

That the Board of Trustees review and approve the District's investment policy to comply with the Public Funds Investment Act (Texas Government Code Chapter 2256, Subchapter A).

IMPACT/RATIONALE:

Policies CDA (LEGAL) and CDA (LOCAL) follow for your review.

The Public Funds Investment Act requires that the investment policy and investment strategies of the District be reviewed annually. For compliance with the Act, the Board shall adopt a written instrument stating that it has reviewed the investment policy and investment strategies. The written instrument so adopted shall record any changes made to either the investment policy or investment strategies. The attached resolution shall serve as that written instrument.

Submitted by: Jill Ludwig, CPA, RTSBA, Chief Financial Officer
Yvonne Dawson, RTSBA, Director of Budget & Treasury
Michele Reynolds, CPA, Director of Finance

Recommended for approval:



Dr. Thomas Randle
Superintendent

LAMAR CONSOLIDATED INDEPENDENT SCHOOL DISTRICT

RESOLUTION OF ANNUAL REVIEW OF THE INVESTMENT POLICY OF Lamar Consolidated Independent School District

WHEREAS, Lamar Consolidated ISD, (the “District”) has been legally created and operates pursuant to the general laws of the State of Texas applicable to Independent School Districts; and

Whereas, the Board of Trustees has convened on this date at a meeting open to the public and wishes to review the Investment Policy for the District, in the form attached hereto, pursuant to Chapter 2256, The Texas Government Code, as amended from time to time; Now, therefore,

BE IT RESOLVED BY THE BOARD OF TRUSTEES OF THE DISTRICT THAT:

Section 1: The Investment Policy, in the form attached hereto is hereby reviewed and approved at its annual review.

Section 2: The provisions of this resolution shall be effective as of the date reviewed and shall remain in effect until modified by action of the Board of Trustees.

PASSED AND APPROVED this 16th day of August 2018.

James Steenbergen
President, Board of Trustees

ATTEST:

Kathryn Kaminski
Secretary, Board of Trustees

Table of Contents	Definitions	2
	Business Organization.....	2
	Investment Pool.....	2
	Pooled Fund Group	2
	Separately Invested Asset	2
	Repurchase Agreement.....	2
	Hedging.....	2
	Corporate Bond	3
	Written Policies	3
	Annual Review	4
	Annual Audit	4
	Investment Strategies.....	4
	Investment Officer	4
	Investment Training	5
	Standard of Care	5
	Selection of Broker	7
	Authorized Investments	7
	Obligations of Governmental Entities.....	8
	Certificates of Deposit and Share Certificates.....	9
	Repurchase Agreements	10
	Securities Lending Program	11
	Banker’s Acceptances	12
	Commercial Paper.....	12
	Mutual Funds.....	12
	Guaranteed Investment Contracts.....	13
	Investment Pools.....	14
	Corporate Bonds for Larger Districts	15
	Hedging Transactions.....	16
	Prohibited Investments	16
	Loss of Required Rating	17
	Sellers of Investments	17
	Donations	18
	Electronic Funds Transfer	18

All investments made by a district shall comply with the Public Funds Investment Act (Texas Government Code Chapter 2256, Subchapter A) and all federal, state, and local statutes, rules, or regulations. *Gov't Code 2256.026*

Definitions

Business Organization	“Business organization” means an investment pool or investment management firm under contract with a district to invest or manage the district’s investment portfolio that has accepted authority granted by the district under the contract to exercise investment discretion in regard to the district’s funds. <i>Gov’t Code 2256.005(k)</i>
Investment Pool	“Investment pool” means an entity created under the Texas Government Code to invest public funds jointly on behalf of the entities that participate in the pool and whose investment objectives in order of priority are preservation and safety of principal, liquidity, and yield.
Pooled Fund Group	“Pooled fund group” means an internally created fund of a district in which one or more institutional accounts of a district are invested.
Separately Invested Asset	“Separately invested asset” means an account or fund of a district that is not invested in a pooled fund group. <i>Gov’t Code 2256.002(6), (9), (12)</i>
Repurchase Agreement	“Repurchase agreement” means a simultaneous agreement to buy, hold for a specified time, and sell back at a future date obligations, described at Obligations of Governmental Entities, below, at a market value at the time the funds are disbursed of not less than the principal amount of the funds disbursed. The term includes a direct security repurchase agreement and a reverse security repurchase agreement. <i>Gov’t Code 2256.011(b)</i>
Hedging	“Hedging” means acting to protect against economic loss due to price fluctuation of a commodity or related investment by entering into an offsetting position or using a financial agreement or producer price agreement in a correlated security, index, or other commodity.
<i>Eligible Entity</i>	“Eligible entity” means a political subdivision that has: <ol style="list-style-type: none">1. A principal amount of at least \$250 million in outstanding long-term indebtedness, long-term indebtedness proposed to be issued, or a combination of outstanding long-term indebtedness and long-term indebtedness proposed to be issued; and2. Outstanding long-term indebtedness that is rated in one of the four highest rating categories for long-term debt instruments by a nationally recognized rating agency for municipal securi-

ties, without regard to the effect of any credit agreement or other form of credit enhancement entered into in connection with the obligation.

Eligible Project “Eligible project” has the meaning assigned by Government Code 1371.001 (regarding issuance of obligations for certain public improvements).

Gov’t Code 2256.0206(a)

Corporate Bond “Corporate bond” means a senior secured debt obligation issued by a domestic business entity and rated not lower than “AA-” or the equivalent by a nationally recognized investment rating firm. The term does not include a debt obligation that, on conversion, would result in the holder becoming a stockholder or shareholder in the entity, or any affiliate or subsidiary of the entity, that issued the debt obligation, or is an unsecured debt obligation. *Gov’t Code 2256.0204(a)*

Written Policies

The board shall adopt by resolution a written investment policy regarding the investment of its funds and funds under its control. The investment policies must primarily emphasize safety of principal and liquidity and must address investment diversification, yield, and maturity and the quality and capability of investment management. The policies must include:

1. A list of the types of authorized investments in which the district’s funds may be invested;
2. The maximum allowable stated maturity of any individual investment owned by the district;
3. For pooled fund groups, the maximum dollar-weighted average maturity allowed based on the stated maturity date of the portfolio;
4. Methods to monitor the market price of investments acquired with public funds;
5. A requirement for settlement of all transactions, except investment pool funds and mutual funds, on a delivery versus payment basis; and
6. Procedures to monitor rating changes in investments acquired with public funds and the liquidation of such investments consistent with the provisions of Government Code 2256.021 [see Loss of Required Rating, below].

Gov’t Code 2256.005(a), (b)

OTHER REVENUES
INVESTMENTS

CDA
(LEGAL)

Annual Review	The board shall review its investment policy and investment strategies not less than annually. The board shall adopt a written instrument by resolution stating that it has reviewed the investment policy and investment strategies and that the written instrument so adopted shall record any changes made to either the investment policy or investment strategies. <i>Gov't Code 2256.005(e)</i>
Annual Audit	A district shall perform a compliance audit of management controls on investments and adherence to the district's established investment policies. The compliance audit shall be performed in conjunction with the annual financial audit. <i>Gov't Code 2256.005(m)</i>
Investment Strategies	<p>As an integral part of the investment policy, the board shall adopt a separate written investment strategy for each of the funds or group of funds under the board's control. Each investment strategy must describe the investment objectives for the particular fund using the following priorities in order of importance:</p> <ol style="list-style-type: none">1. Understanding of the suitability of the investment to the financial requirements of the district;2. Preservation and safety of principal;3. Liquidity;4. Marketability of the investment if the need arises to liquidate the investment before maturity;5. Diversification of the investment portfolio; and6. Yield. <p><i>Gov't Code 2256.005(d)</i></p>
Investment Officer	A district shall designate by resolution one or more officers or employees as investment officer(s) to be responsible for the investment of its funds consistent with the investment policy adopted by the board. If the board has contracted with another investing entity to invest its funds, the investment officer of the other investing entity is considered to be the investment officer of the contracting board's district. In the administration of the duties of an investment officer, the person designated as investment officer shall exercise the judgment and care, under prevailing circumstances, that a prudent person would exercise in the management of the person's own affairs, but the board retains the ultimate responsibility as fiduciaries of the assets of the district. Unless authorized by law, a person may not deposit, withdraw, transfer, or manage in any other manner the funds of the district. Authority granted to a person to invest the district's funds is effective until rescinded by the district or until termination of the person's employment by a district, or for

an investment management firm, until the expiration of the contract with the district. *Gov't Code 2256.005(f)*

A district or investment officer may use the district's employees or the services of a contractor of the district to aid the investment officer in the execution of the officer's duties under Government Code, Chapter 2256. *Gov't Code 2256.003(c)*

Investment Training

Initial

Within 12 months after taking office or assuming duties, the treasurer, the chief financial officer if the treasurer is not the chief financial officer, and the investment officer of a district shall attend at least one training session from an independent source approved by the board or a designated investment committee advising the investment officer. This initial training must contain at least ten hours of instruction relating to their respective responsibilities under the Public Funds Investment Act. *Gov't Code 2256.008(a)*

Ongoing

The treasurer, or the chief financial officer if the treasurer is not the chief financial officer, and the investment officer of a district shall attend an investment training session not less than once in a two-year period that begins on the first day of the district's fiscal year and consists of the two consecutive fiscal years after that date, and receive not less than eight hours of instruction relating to investment responsibilities under the Public Funds Investment Act from an independent source approved by the board or by a designated investment committee advising the investment officer. *Gov't Code 2256.008(a-1)*

Investment training must include education in investment controls, security risks, strategy risks, market risks, diversification of investment portfolio, and compliance with the Public Funds Investment Act. *Gov't Code 2256.008(c)*

Standard of Care

Investments shall be made with judgment and care, under prevailing circumstances, that a person of prudence, discretion, and intelligence would exercise in the management of the person's own affairs, not for speculation, but for investment, considering the probable safety of capital and the probable income to be derived. Investment of funds shall be governed by the following objectives, in order of priority:

1. Preservation and safety of principal;
2. Liquidity; and
3. Yield.

In determining whether an investment officer has exercised prudence with respect to an investment decision, the following shall be taken into consideration:

OTHER REVENUES
INVESTMENTS

CDA
(LEGAL)

1. The investment of all funds, or funds under the district's control, over which the office had responsibility rather than the prudence of a single investment; and
2. Whether the investment decision was consistent with the district's written investment policy.

Gov't Code 2256.006

Personal Interest

A district investment officer who has a personal business relationship with a business organization offering to engage in an investment transaction with the district shall file a statement disclosing that personal business interest. An investment officer who is related within the second degree by affinity or consanguinity, as determined by Government Code Chapter 573 (regarding nepotism prohibition), to an individual seeking to sell an investment to the investment officer's district shall file a statement disclosing that relationship. A required statement must be filed with the board and with the Texas Ethics Commission. For purposes of this policy, an investment officer has a personal business relationship with a business organization if:

1. The investment officer owns ten percent or more of the voting stock or shares of the business organization or owns \$5,000 or more of the fair market value of the business organization;
2. Funds received by the investment officer from the business organization exceed ten percent of the investment officer's gross income for the previous year; or
3. The investment officer has acquired from the business organization during the previous year investments with a book value of \$2,500 or more for the personal account of the investment officer.

Gov't Code 2256.005(i)

Quarterly Reports

Not less than quarterly, the investment officer shall prepare and submit to the board a written report of investment transactions for all funds covered by the Public Funds Investment Act for the preceding reporting period. This report shall be presented not less than quarterly to the board and the superintendent within a reasonable time after the end of the period. The report must:

1. Describe in detail the investment position of the district on the date of the report;
2. Be prepared jointly and signed by all district investment officers;

3. Contain a summary statement of each pooled fund group that states the:
 - a. Beginning market value for the reporting period;
 - b. Ending market value for the period; and
 - c. Fully accrued interest for the reporting period;
4. State the book value and market value of each separately invested asset at the end of the reporting period by the type of asset and fund type invested;
5. State the maturity date of each separately invested asset that has a maturity date;
6. State the account or fund or pooled group fund in the district for which each individual investment was acquired; and
7. State the compliance of the investment portfolio of the district as it relates to the investment strategy expressed in the district's investment policy and relevant provisions of the Public Funds Investment Act.

If a district invests in other than money market mutual funds, investment pools or accounts offered by its depository bank in the form of certificates of deposit, or money market accounts or similar accounts, the reports prepared by the investment officers shall be formally reviewed at least annually by an independent auditor, and the result of the review shall be reported to the board by that auditor.

Gov't Code 2256.023

Selection of Broker

The board or the designated investment committee shall, at least annually, review, revise, and adopt a list of qualified brokers that are authorized to engage in investment transactions with a district.
Gov't Code 2256.025

Authorized Investments

A board may purchase, sell, and invest its funds and funds under its control in investments described below, in compliance with its adopted investment policies and according to the standard of care set out in this policy. *Gov't Code 2256.003(a)*

In the exercise of these powers, the board may contract with an investment management firm registered under the Investment Advisers Act of 1940 (15 U.S.C. Section 80b-1 et seq.) or with the State Securities Board to provide for the investment and management of its public funds or other funds under its control. A contract made under this authority may not be for a term longer than two

OTHER REVENUES
INVESTMENTS

CDA
(LEGAL)

years. A renewal or extension of the contract must be made by the board by resolution. *Gov't Code 2256.003(b)*

The board may specify in its investment policy that any authorized investment is not suitable. *Gov't Code 2256.005(j)*

The following are authorized investments:

Obligations of
Governmental
Entities

1. Obligations, including letters of credit, of the United States or its agencies and instrumentalities, including the Federal Home Loan Banks;
2. Direct obligations of this state or its agencies and instrumentalities;
3. Collateralized mortgage obligations directly issued by a federal agency or instrumentality of the United States, the underlying security for which is guaranteed by an agency or instrumentality of the United States;
4. Other obligations, the principal and interest of which are unconditionally guaranteed or insured by, or backed by the full faith and credit of, this state, the United States, or their respective agencies and instrumentalities, including obligations that are fully guaranteed or insured by the Federal Deposit Insurance Corporation (FDIC) or by the explicit full faith and credit of the United States;
5. Obligations of states, agencies, counties, cities, and other political subdivisions of any state rated as to investment quality by a nationally recognized investment rating firm not less than A or its equivalent;
6. Bonds issued, assumed, or guaranteed by the state of Israel;
7. Interest-bearing banking deposits that are guaranteed or insured by the FDIC or its successor, or the National Credit Union Share Insurance Fund or its successor; and
8. Interest-bearing banking deposits other than those described at item 7 above if:
 - a. The funds are invested through a broker with a main office or a branch office in this state that the district selects from a list the board or designated investment committee of the district adopts as required at Selection of Broker above or a depository institution with a main office or a branch office in this state and that the district selects;
 - b. The broker or depository institution selected as described above arranges for the deposit of the funds in

the banking deposits in one or more federally insured depository institutions, regardless of where located, for the district's account;

- c. The full amount of the principal and accrued interest of the banking deposits is insured by the United States or an instrumentality of the United States; and
- d. The district appoints as the district's custodian of the banking deposits issued for the district's account the depository institution selected as described above, an entity described by Government Code 2257.041(d) (regarding a custodian with which to deposit securities), or a clearing broker-dealer registered with the Securities and Exchange Commission and operating under Rule 15c3-3 (17 C.F.R. Section 240.15c3-3).

Gov't Code 2256.009(a)

*Unauthorized
Obligations*

The following investments are not authorized:

- 1. Obligations whose payment represents the coupon payments on the outstanding principal balance of the underlying mortgage-backed security collateral and pays no principal;
- 2. Obligations whose payment represents the principal stream of cash flow from the underlying mortgage-backed security collateral and bears no interest;
- 3. Collateralized mortgage obligations that have a stated final maturity date of greater than ten years; and
- 4. Collateralized mortgage obligations the interest rate of which is determined by an index that adjusts opposite to the changes in a market index.

Gov't Code 2256.009(b)

*Certificates of
Deposit and Share
Certificates*

A certificate of deposit or share certificate is an authorized investment if the certificate is issued by a depository institution that has its main office or a branch office in Texas and is:

- 1. Guaranteed or insured by the FDIC or its successor or the National Credit Union Share Insurance Fund or its successor;
- 2. Secured by obligations described at Obligations of Governmental Entities, above, including mortgage backed securities directly issued by a federal agency or instrumentality that have a market value of not less than the principal amount of the certificates, but excluding those mortgage backed securities described at Unauthorized Obligations, above; or

3. Secured in accordance with Government Code Chapter 2257 (Public Funds Collateral Act) or in any other manner and amount provided by law for the deposits of the district.

Gov't Code 2256.010(a)

In addition to the authority to invest funds in certificates of deposit under the previous section, an investment in certificates of deposit made in accordance with the following conditions is an authorized investment:

1. The funds are invested by the district through a broker that has its main office or a branch office in this state and is selected from a list adopted by the district as required at Selection of Broker, above or a depository institution that has its main office or a branch office in this state and that is selected by the district;
2. The broker or depository institution selected by the district arranges for the deposit of the funds in certificates of deposit in one or more federally insured depository institutions, wherever located, for the account of the district;
3. The full amount of the principal and accrued interest of each of the certificates of deposit is insured by the United States or an instrumentality of the United States; and
4. The district appoints the depository institution selected by the district, an entity described by Government Code 2257.041(d) (regarding a custodian with which to deposit securities), or a clearing broker-dealer registered with the Securities and Exchange Commission and operating pursuant to Securities and Exchange Commission Rule 15c3-3 (17 C.F.R. Section 240.15c3-3) as custodian for the district with respect to the certificates of deposit issued for the account of the district.

Gov't Code 2256.010(b)

The district's investment policies may provide that bids for certificates of deposit be solicited orally, in writing, electronically, or in any combination of those methods. *Gov't Code 2256.005(c)*

Repurchase
Agreements

A fully collateralized repurchase agreement is an authorized investment if it:

1. Has a defined termination date;
2. Is secured by a combination of cash and obligations described at Obligations of Governmental Entities, above;

OTHER REVENUES
INVESTMENTS

CDA
(LEGAL)

3. Requires the securities being purchased by the district or cash held by the district to be pledged to the district, held in the district's name, and deposited at the time the investment is made with the district or a third party selected and approved by the district, and
4. Is placed through a primary government securities dealer, as defined by the Federal Reserve or a financial institution doing business in Texas.

The term of any reverse security repurchase agreement may not exceed 90 days after the date the reverse security repurchase agreement is delivered. Money received by a district under the terms of a reverse security repurchase agreement shall be used to acquire additional authorized investments, but the term of the authorized investments acquired must mature not later than the expiration date stated in the reverse security repurchase agreement.

Government Code 1371.059(c) (regarding validity and incontestability of obligations for certain public improvements) applies to the execution of a repurchase agreement by a district.

Gov't Code 2256.011

Securities Lending
Program

A securities lending program is an authorized investment if:

1. The value of securities loaned is not less than 100 percent collateralized, including accrued income;
2. A loan allows for termination at any time;
3. A loan is secured by:
 - a. Pledged securities described at Obligations of Governmental Entities, above;
 - b. Pledged irrevocable letters of credit issued by a bank that is organized and existing under the laws of the United States or any other state, and continuously rated by at least one nationally recognized investment rating firm at not less than A or its equivalent; or
 - c. Cash invested in accordance with Government Code 2256.009 (obligations of governmental entities), 2256.013 (commercial paper), 2256.014 (mutual funds), or 2256.01 (investment pools);
4. The terms of a loan require that the securities being held as collateral be pledged to the district, held in the district's name, and deposited at the time the investment is made with the dis-

OTHER REVENUES
INVESTMENTS

CDA
(LEGAL)

trict or with a third party selected by or approved by the district; and

5. A loan is placed through a primary government securities dealer, as defined by 5 C.F.R. Section 6801.102(f), as that regulation existed on September 1, 2003, or a financial institution doing business in this state.

An agreement to lend securities under a securities lending program must have a term of one year or less.

Gov't Code 2256.0115

Banker's
Acceptances

A banker's acceptance is an authorized investment if it:

1. Has a stated maturity of 270 days or fewer from the date of issuance;
2. Will be, in accordance with its terms, liquidated in full at maturity;
3. Is eligible for collateral for borrowing from a Federal Reserve Bank; and
4. Is accepted by a bank organized and existing under the laws of the United States or any state, if the short-term obligations of the bank, or of a bank holding company of which the bank is the largest subsidiary, are rated not less than A-1 or P-1 or an equivalent rating by at least one nationally recognized credit rating agency.

Gov't Code 2256.012

Commercial Paper

Commercial paper is an authorized investment if it has a stated maturity of 270 days or fewer from the date of issuance; and is rated not less than A-1 or P-1 or an equivalent rating by at least:

1. Two nationally recognized credit rating agencies; or
2. One nationally recognized credit rating agency and is fully secured by an irrevocable letter of credit issued by a bank organized and existing under the laws of the United States law or any state.

Gov't Code 2256.013

Mutual Funds

A no-load money market mutual fund is an authorized investment if the mutual fund:

1. Is registered with and regulated by the Securities and Exchange Commission;

OTHER REVENUES
INVESTMENTS

CDA
(LEGAL)

2. Provides the district with a prospectus and other information required by the Securities and Exchange Act of 1934 (15 U.S.C. 78a et seq.) or the Investment Company Act of 1940 (15 U.S.C. 80a-1 et seq.); and
3. Complies with federal Securities and Exchange Commission Rule 2a-7 (17 C.F.R. Section 270.2a-7), promulgated under the Investment Company Act of 1940 (15 U.S.C. Section 80a-1 et seq.).

Gov't Code 2256.014(a)

In addition to the no-load money market mutual fund authorized above, a no-load mutual fund is an authorized investment if it:

1. Is registered with the Securities and Exchange Commission;
2. Has an average weighted maturity of less than two years; and
3. Either has a duration of less than one year or more and is invested exclusively in obligations approved by the Public Funds Investment Act, or has a duration of less than one year and the investment portfolio is limited to investment grade securities, excluding asset-backed securities.

Gov't Code 2256.014(b)

Limitations

A district is not authorized to:

1. Invest in the aggregate more than 15 percent of its monthly average fund balance, excluding bond proceeds and reserves and other funds held for debt service, in mutual funds described in Government Code 2256.014(b);
2. Invest any portion of bond proceeds, reserves and funds held for debt service, in mutual funds described in Government Code 2256.014(b); or
3. Invest its funds or funds under its control, including bond proceeds and reserves and other funds held for debt service, in any one mutual fund described in Government Code 2256.014(a) or (b) in an amount that exceeds ten percent of the total assets of the mutual fund.

Gov't Code 2256.014(c)

Guaranteed
Investment
Contracts

A guaranteed investment contract is an authorized investment for bond proceeds if the guaranteed investment contract:

1. Has a defined termination date;

OTHER REVENUES
INVESTMENTS

CDA
(LEGAL)

2. Is secured by obligations described at Obligations of Governmental Entities, above, excluding those obligations described at Unauthorized Obligations, in an amount at least equal to the amount of bond proceeds invested under the contract; and
3. Is pledged to the district and deposited with the district or with a third party selected and approved by the district.

Bond proceeds, other than bond proceeds representing reserves and funds maintained for debt service purposes, may not be invested in a guaranteed investment contract with a term longer than five years from the date of issuance of the bonds.

To be eligible as an authorized investment:

1. The board must specifically authorize guaranteed investment contracts as eligible investments in the resolution authorizing the issuance of bonds;
2. The district must receive bids from at least three separate providers with no material financial interest in the bonds from which proceeds were received;
3. The district must purchase the highest yielding guaranteed investment contract for which a qualifying bid is received;
4. The price of the guaranteed investment contract must take into account the reasonably expected drawdown schedule for the bond proceeds to be invested; and
5. The provider must certify the administrative costs reasonably expected to be paid to third parties in connection with the guaranteed investment contract.

Government Code 1371.059(c) (regarding validity and incontestability of obligations for certain public improvements) applies to the execution of a guaranteed investment contract by a district.

Gov't Code 2256.015

Investment Pools

A district may invest its funds or funds under its control through an eligible investment pool if the board by resolution authorizes the investment in the particular pool. *Gov't Code 2256.016, .019*

To be eligible to receive funds from and invest funds on behalf of a district, an investment pool must furnish to the investment officer or other authorized representative of the district an offering circular or other similar disclosure instrument that contains the information specified in Government Code 2256.016(b). To maintain eligibility, an investment pool must furnish to the investment officer or other

OTHER REVENUES
INVESTMENTS

CDA
(LEGAL)

authorized representative investment transaction confirmations and a monthly report that contains the information specified in Government Code 2256.016(c). A district by contract may delegate to an investment pool the authority to hold legal title as custodian of investments purchased with its local funds. *Gov't Code 2256.016(b)-(d)*

Corporate Bonds for
Larger Districts

A district that qualifies as an issuer as defined by Government Code 1371.001 [see CCF], may purchase, sell, and invest its funds and funds under its control in corporate bonds (as defined above) that, at the time of purchase, are rated by a nationally recognized investment rating firm "AA-" or the equivalent and have a stated final maturity that is not later than the third anniversary of the date the corporate bonds were purchased.

A district is not authorized to:

1. Invest in the aggregate more than 15 percent of its monthly average fund balance, excluding bond proceeds, reserves, and other funds held for the payment of debt service, in corporate bonds; or
2. Invest more than 25 percent of the funds invested in corporate bonds in any one domestic business entity, including subsidiaries and affiliates of the entity.

A district subject to these provisions may purchase, sell, and invest its funds and funds under its control in corporate bonds if the board:

1. Amends its investment policy to authorize corporate bonds as an eligible investment;
2. Adopts procedures to provide for monitoring rating changes in corporate bonds acquired with public funds and liquidating the investment in corporate bonds; and
3. Identifies the funds eligible to be invested in corporate bonds.

The district investment officer, acting on behalf of the district, shall sell corporate bonds in which the district has invested its funds not later than the seventh day after the date a nationally recognized investment rating firm:

1. Issues a release that places the corporate bonds or the domestic business entity that issued the corporate bonds on negative credit watch or the equivalent, if the corporate bonds are rated "AA-" or the equivalent at the time the release is issued; or

OTHER REVENUES
INVESTMENTS

CDA
(LEGAL)

2. Changes the rating on the corporate bonds to a rating lower than "AA-" or the equivalent.

Corporate bonds are not an eligible investment for a public funds investment pool.

Gov't Code 2256.0204

Hedging
Transactions

The board of an eligible entity (as defined above) shall establish the entity's policy regarding hedging transactions. An eligible entity may enter into hedging transactions, including hedging contracts, and related security, credit, and insurance agreements in connection with commodities used by an eligible entity in the entity's general operations, with the acquisition or construction of a capital project, or with an eligible project. A hedging transaction must comply with the regulations of the federal Commodity Futures Trading Commission and the federal Securities and Exchange Commission.

Government Code 1371.059(c) (regarding validity and incontestability of obligations for certain public improvements) applies to the execution by an eligible entity of a hedging contract and any related security, credit, or insurance agreement.

An eligible entity may:

1. Pledge as security for and to the payment of a hedging contract or a security, credit, or insurance agreement any general or special revenues or funds the entity is authorized by law to pledge to the payment of any other obligation.
2. Credit any amount the entity receives under a hedging contract against expenses associated with a commodity purchase.

An eligible entity's cost of or payment under a hedging contract or agreement may be considered an operation and maintenance expense, an acquisition expense, or construction expense of the eligible entity; or a project cost of an eligible project.

Gov't Code 2256.0206

Prohibited
Investments

Except as provided by Government Code 2270 (regarding prohibited investments), a district is not required to liquidate investments that were authorized investments at the time of purchase. *Gov't Code 2256.017*

Note: As an “investing entity” under Government Code 2270.0001(7)(A), a district must comply with Chapter 2270, including reporting requirements, regarding prohibited investments in scrutinized companies listed by the comptroller in accordance with Government Code 2270.0201.

Loss of Required
Rating

An investment that requires a minimum rating does not qualify as an authorized investment during the period the investment does not have the minimum rating. A district shall take all prudent measures that are consistent with its investment policy to liquidate an investment that does not have the minimum rating. *Gov’t Code 2256.021*

**Sellers of
Investments**

A written copy of the investment policy shall be presented to any business organization (as defined above) offering to engage in an investment transaction with a district. The qualified representative of the business organization offering to engage in an investment transaction with a district shall execute a written instrument in a form acceptable to the district and the business organization substantially to the effect that the business organization has:

1. Received and reviewed the district investment policy; and
2. Acknowledged that the business organization has implemented reasonable procedures and controls in an effort to preclude investment transactions conducted between the district and the organization that are not authorized by the district’s investment policy, except to the extent that this authorization:
 - a. Is dependent on an analysis of the makeup of the district’s entire portfolio;
 - b. Requires an interpretation of subjective investment standards; or
 - c. Relates to investment transactions of the entity that are not made through accounts or other contractual arrangements over which the business organization has accepted discretionary investment authority.

The investment officer of a district may not acquire or otherwise obtain any authorized investment described in the district’s investment policy from a business organization that has not delivered to the district the instrument required above.

Gov’t Code 2256.005(k)–(l)

OTHER REVENUES
INVESTMENTS

CDA
(LEGAL)

Nothing in this section relieves the district of the responsibility for monitoring investments made by the district to determine that they are in compliance with the investment policy. *Gov't Code 2256.005(k)*

Donations

A gift, devise, or bequest made to a district to provide college scholarships for district graduates may be invested by the board as provided in Property Code 117.004 (Uniform Prudent Investor Act), unless otherwise specifically provided by the terms of the gift, devise, or bequest. *Education Code 45.107*

Investments donated to a district for a particular purpose or under terms of use specified by the donor are not subject to the requirements of the Public Funds Investment Act. *Gov't Code 2256.004(b)*

**Electronic Funds
Transfer**

A district may use electronic means to transfer or invest all funds collected or controlled by the district. *Gov't Code 2256.051*

OTHER REVENUES
INVESTMENTS

CDA
(LOCAL)

Policy	It is the policy of the District to invest public funds in a manner that ensures the safety of invested funds, maintains sufficient liquidity to provide for the daily needs of the District, and achieves maximum yield in relation to the risk assumed. Safety of invested principal, however, remains highest in priority.
Investment Authority	The chief financial officer, the budget and treasury officer, and the director of finance shall serve as the investment officers of the District and shall invest District funds as directed by the Board and in accordance with the District's written investment policy and generally accepted accounting procedures.
Scope	This investment policy applies to all financial assets of the District. These funds are accounted for in the District's comprehensive annual financial report and include:
General Fund	The general fund usually includes transactions as a result of revenues from local maintenance taxes, Foundation School Program entitlements, and other locally generated sources.
Special Revenue Funds	Special revenue funds are governmental funds used to account for the proceeds of specific revenue sources that are legally restricted to expenditures for specified purposes.
Debt Service Funds	A debt service fund is a governmental fund, with budgetary control, that must be used to account for general long-term debt principal and interest for debt issues and other long-term debts for which a tax has been dedicated.
Capital Projects Funds	A capital projects fund is a governmental fund that must be used to account, on a project basis, for projects financed by the proceeds from bond issues, or for capital projects otherwise mandated to be accounted for in this fund.
Internal Service Funds	Internal service funds are proprietary funds accounted for on the accrual basis.
Trust and Agency Funds	This group of funds is used to account for assets held by a school district in a trustee capacity of the District, or as an agent for individuals, private organizations, other governmental units and/or other funds. This fund type consists of expendable trust funds, nonexpendable trust funds, pension trust funds and agency funds.
Texas Teacher Retirement Fund	<p>The Texas Teacher Retirement Fund shall not be covered by this policy.</p> <p>All employees of the District employed for one-half or more of the standard work load, and who are not exempted from membership under Government Code, Section 822.002, are required to participate in the Teacher Retirement System of Texas, a multiple-</p>

employer public employee retirement system. It is a cost-sharing public employee retirement system with one exception—all risks and costs are not shared by the District, but are the liability of the state of Texas, and as such, all investments are maintained by the Teacher Retirement System.

Objectives

The primary objectives, in priority order, of investment activities shall be safety, liquidity, and yield:

Safety

1. Safety of principal is the foremost objective of the investment program. Investments shall be undertaken in a manner that seeks to ensure the preservation of capital in the overall portfolio. The objective will be to mitigate credit risk and interest rate risk.
 - a. The District will minimize credit risk, which is the risk of loss due to the failure of the security issuer or backer, by:
 - (1) Limiting investments to the types of securities listed in this investment policy;
 - (2) Pre-qualifying the financial institutions, brokers/dealers, and advisors with which the District will do business in accordance with this policy; and
 - (3) Diversifying the investment portfolio so that the impact of potential losses from any one type of security or from any one individual issuer will be minimized.
 - b. To reduce exposure to changes in interest rates that could adversely affect the value of investments, the District shall use final and weighted-average-maturity limits and diversification.

The District shall monitor interest rate risk using weighted average maturity and specific identification.

Liquidity

2. The investment portfolio shall remain sufficiently liquid to meet all operating requirements that may be reasonably anticipated. This is accomplished by structuring the portfolio so that securities mature concurrent with cash needs to meet anticipated demands (static liquidity). Furthermore, since all possible cash demands cannot be anticipated, the portfolio should consist largely of securities with active secondary or resale markets (dynamic liquidity). Alternatively, a portion of the portfolio may be placed in money market mutual funds or local government investment pools that offer same-day liquidity for short-term funds.

OTHER REVENUES
INVESTMENTS

CDA
(LOCAL)

Yield

3. The investment portfolio shall be designed with the objective of attaining a market rate of return throughout budgetary and economic cycles, taking into account the investment risk constraints and liquidity needs. Return on investment is of secondary importance compared to the safety and liquidity objectives described above. The core of investments are limited to relatively low risk securities in anticipation of earning a fair return relative to the risk being assumed. Securities shall generally be held until maturity with the following exceptions:
 - a. A security with declining credit may be sold early to minimize loss of principal.
 - b. A security swap would improve the quality, yield, or target duration in the portfolio.
 - c. Liquidity needs of the portfolio require that the security be sold.

Fund Strategies

Appropriate investment strategies shall be developed by fund category. The strategies must define the investment objectives for each fund type, with priority consideration being given to the suitability of the investment for the type of funds being invested, the preservation and safety of principal, liquidity, marketability, diversification, and yield. Investments shall be made in accordance with these objectives, and the maximum allowable stated maturity for any individual security may exceed one year provided legal limits are not exceeded.

The District shall have a similar investment strategy for each of the following covered funds:

1. General fund.
2. Special revenue fund(s)—including funds used to account for federal, state, and local grants, as well as the food service fund and the campus activity fund.
3. Debt service fund(s).
4. Capital project fund(s).
5. Proprietary fund(s)—including the funds used to account for the workers' compensation and medical self-insurance programs.
6. Trust and agency funds-including the student activity fund.

The District shall follow the investment strategies listed below (in order of importance) for each covered fund:

OTHER REVENUES
INVESTMENTS

CDA
(LOCAL)

1. Each investment option shall be reviewed to ensure understanding of the suitability of the investment to the financial requirements of the District;
2. Investments shall be selected that provide preservation and safety of invested funds;
3. Investment strategies for all covered funds shall have as their objective sufficient investment liquidity to timely meet obligations. Maturities longer than one year are authorized provided legal limits are not exceeded;
4. The investment shall be marketable if the need arises to liquidate invested funds before maturity;
5. The investment type shall be consistent with the Board's desired diversification of the investment portfolio; and
6. All invested funds of the District shall attain a rate of return commensurate with the District's investment risk constraints and the cash flow characteristics of the portfolio.

The District shall diversify its investments in all funds by security type and institution. The District shall consider purchase of high quality short-term to medium-term securities that will complement each other in a laddered or liability-matching portfolio structure.

Prudence

Investments shall be made with judgment and care—under circumstances then prevailing which persons of prudence, discretion and intelligence exercise in the management of their own affairs, not for speculation, but for investment, considering the probable safety of their capital as well as the probable income to be derived.

The standard of prudence to be used by investment officials shall be the “prudent person” standard and shall be applied in the context of managing an overall portfolio. Investment officers acting in accordance with written procedures and the investment policy and exercising due diligence shall be relieved of personal responsibility for an individual security’s credit risk or market price changes, provided deviations from expectations are reported in a timely fashion and appropriate action is taken to control adverse developments.

In determining whether an investment official has exercised prudence with respect to an investment decision, the determination shall be made taking into consideration the investment of all funds over which the official had responsibility rather than consideration as to the prudence of a single investment and, whether the investment decision was consistent with the District’s investment policy and written investment procedures.

**Ethics and Conflicts
of Interest**

Officers and employees involved in the investment process shall refrain from personal business activity that could conflict with proper execution of the investment program, or which could impair their ability to make impartial investment decisions.

Officers and employees involved in the investment process shall sign annual statements agreeing to abide by this section of the investment policy and affirming no known conflicts of interest.

An officer or employee involved in the investment process has a personal business relationship with a business organization if:

1. The officer or employee owns ten percent or more of the voting stock or shares of the business organization or owns \$5,000 or more of the fair market value of the business organization;
2. Funds received by the officer or employee from the business organization exceed ten percent of his/her gross income for the previous year;
3. The officer or employee has acquired from the business organization during the previous year investments with a book value of \$2,500 or more for his/her personal account; or
4. The officer is related within the second degree by affinity or consanguinity, as determined under Chapter 573 of the Texas Government Code, to an individual seeking to transact investment business with the entity.

If the investment officer has a personal business relationship with a business organization, a disclosure statement must be filed with the Texas Ethics Commission.

**Authorized
Investments**

From those investments authorized by law and described in CDA(LEGAL), the Board shall permit investment of District funds in the following investment types only, consistent with the strategies and maturities defined in this policy:

1. Obligations of the United States or its agencies and instrumentalities; direct obligations of the state of Texas or its agencies; other obligations, the principal and interest of which are unconditionally guaranteed or insured by, or backed by the full faith and credit of the state of Texas, the United States, or its instrumentalities; including obligations that are fully guaranteed or insured by the Federal Deposit Insurance Corporation (FDIC) or by the explicit full faith and credit of the United States; obligations of states, agencies, counties, cities, and other political subdivisions of any state rated as to in-

vestment quality by a nationally recognized investment rating firm not less than A or its equivalent. *Gov't Code 2256.009*

2. Certificates of deposit or share certificates issued by a depository institution that has its main office or a branch office in Texas that is guaranteed or insured by the FDIC or its successor or the National Credit Union Share Insurance Fund or its successor and is secured by obligations described in item 1 above, including mortgage-backed securities directly issued by a federal agency or instrumentality that have a market value of not less than the principal amount of the certificates or are secured in any other manner and amount provided by law for the deposits of the investment entity. *Gov't Code 2256.010*

In addition to the authority to invest funds in certificates of deposit under the previous section, an investment in certificates of deposit made in accordance with the following conditions is an authorized investment under Government Code 2256.010:

- a. The funds are invested by the District through a broker that has its main office or a branch office in this state and is selected from a list adopted by the District as required by Government Code 2256.025, or a depository institution that has its main office or a branch office in this state and that is selected by the District;
- b. The broker or depository institution selected by the District arranges for the deposit of the funds in certificates of deposit in one or more federally insured depository institutions, wherever located, for the account of the District;
- c. The full amount of the principal and accrued interest of each of the certificates of deposit is insured by the United States or an instrumentality of the United States; and
- d. The District appoints the depository institution selected by the District, an entity described by Government Code 2257.041(d), or a clearing broker-dealer registered with the Securities and Exchange Commission and operating pursuant to Securities and Exchange Commission Rule 15c3-3 (17 C.F.R. Section 240.15c3-3) as custodian for the District with respect to the certificates of deposit issued for the account of the District entity.

Gov't Code 2256.010(b)

3. Fully collateralized repurchase agreements that have a defined termination date, are secured by a combination of cash and obligations of the United States or its agencies and instrumentalities, require the securities being purchased by the District or cash held by the District to be pledged to the Dis-

trict, held in the District's name, and deposited with a third party selected and approved by the investment committee, and placed through a primary government securities dealer, as defined by the Federal Reserve or a financial institution doing business in the State of Texas. *Gov't Code 2256.011*

The District shall have a master repurchase agreement signed with the bank or dealer with whom all repurchase agreements are traded.

4. Commercial paper that has a stated maturity of 270 days or fewer from the date of issuance and is rated not less than A1-1 or P-1 or an equivalent rating by at least two nationally recognized credit rating agencies or by one nationally recognized credit rating agency provided the commercial paper is fully secured by an irrevocable letter of credit issued by a bank organized and existing under U.S. law or the law of any state; and to the extent that commercial paper is held through an investment pool and not as an individual issue through the District. *Gov't Code 2256.013.*
5. No-load money market mutual funds that are regulated by the Securities and Exchange Commission, and have a dollar-weighted average stated maturity of 90 days or fewer, are invested exclusively in obligations described by items 1–4 above, and include in their investment objectives the maintenance of a stable net asset value of \$1 for each share. Investments in mutual funds shall be limited to the percentages authorized by Government Code 2256.014(c). *Gov't Code 2256.014.*
6. A public funds investment pool meeting the requirements of Government Code 2256.016, are rated no lower than AAA or an equivalent rating by at least one nationally recognized rating service, and are authorized by resolution or ordinance by the Board. In addition, a local government investment pool created to function as a money market mutual fund must mark its portfolio to the market daily and, to the extent reasonably possible, stabilize at \$1 net asset value. *Gov't Code 2256.016.*
7. Guaranteed investment contracts that have a defined termination date and are secured by obligations described by Government Code 2256.09(a)(1), excluding those obligations described by Government Code 2256.09(b), in an amount at least equal to the amount of bond proceeds invested under the contract; such obligations must be pledged to the District and held in the District's name with an approved third party. *Gov't Code 2256.015.*

Corporate bonds are not an eligible investment for a public funds investment pool. *Gov't Code 2256.0204(g)*

Sellers of Investments

The investment officers will maintain a list of financial institutions, approved by the investment committee, who are authorized to provide investment services. Prior to handling investments on behalf of the District, a broker/dealer or a qualified representative of a business organization must submit required written documents in accordance with law. [See Sellers of Investments, CDA(LEGAL)]

Representatives of brokers/dealers shall be registered with the Texas State Securities Board and must have membership in the Securities Investor Protection Corporation (SIPC), and be in good standing with the Financial Industry Regulatory Authority (FINRA).

A periodic review, at least annually, of the financial condition and registration of new qualified bidders will be conducted by the investment committee. Recommendations will be provided for consideration by the Board as necessary.

Monitoring Market Prices

The investment officers shall keep the Board informed of significant declines in the market value of the District's investment portfolio. Information sources may include financial/investment publications and electronic media, available software for tracking investments, commercial or investment banks, financial advisors, and representatives/advisors of investment pools or money market funds. Monitoring shall be done monthly or more often as economic conditions warrant by using appropriate reports, indices, or benchmarks for the type of investment.

Monitoring Rating Changes

In accordance with Government Code 2256.005(b), the investment officers shall develop a procedure to monitor changes in investment ratings and to liquidate investments that do not maintain satisfactory ratings.

Selection of Depository

The Board shall select and designate a depository institution in accordance with CDA(LEGAL). The depository shall be selected based upon its solvency and stability of leadership as well as on the services provided. The depository shall be selected through a formalized bidding process in response to the District's request for bid (RFB) outlining all services required. Such services should provide the greatest flexibility for money management and should include online account management, positive pay accounts, purchasing card capabilities, and other services considered necessary by District management.

The District shall have the discretion to determine the time span for rebidding the depository contract; however, a three-year period will be the maximum length of time between bidding.

Competitive Bidding

It is the strategy of the District to require competitive bidding for all individual security purchases and sales except for:

1. Transactions with money market mutual funds and local government investment pools (which are deemed to be made at prevailing market rates);
2. Treasury and agency securities purchased at issue through an approved broker/dealer or financial institution; or
3. Automatic overnight "sweep" transactions with the District Depository.

At least three bids or offers must be solicited for all other transactions involving individual securities. The District's investment advisor is also required to solicit at least three bids or offers when transacting trades on the District's behalf. In situations where other dealers do not offer the exact security being offered, offers on the closest comparable investment may be used to establish a fair market price for the security.

Collateral

The investment officers shall ensure that all District funds (principal and accrued interest) are fully collateralized to 110 percent or insured in one or more of the following manners:

1. FDIC insurance coverage; and/or
2. 110 percent of the uninsured value in obligations of the United States or its agencies or instrumentalities or other authorized securities as outlined in item 4 below.
3. All pledged securities shall be held in safekeeping by the District, in a custodial account approved by the District in a third party financial institution, or with a Federal Reserve Bank. The third party custodian shall be required to issue safekeeping receipts directly to the District and to provide a monthly listing of each specific security, rate, description, maturity, CUSIP number, and other information as may be deemed necessary and appropriate by the District. In order to anticipate market changes and provide a level of additional security for all funds, the collateralization level required shall be 110 percent of the market value. The bank shall be liable for pricing securities and providing 110 percent collateralization.
4. Pledged securities shall be limited to only those items which are specifically permitted as approved investment instruments within the definitions of this policy. Should a pledged security fail to meet this requirement, it shall be the sole responsibility of the financial institution to immediately, without notice from

the District or cost to the District, replace any such nonconforming security.

Safekeeping and Custody

Safekeeping and custody of securities and collateral shall be in accordance with state law. It shall be the District's intent to place securities and collateral in the possession of a third party custodian designated by the District where feasible, and held in the District's name as evidenced by safekeeping receipts of the institution with which the securities are deposited.

All investment transactions except investment pool funds and mutual funds will be executed by delivery vs. payment (DVP) to ensure that securities are deposited in an eligible financial institution prior to the release of funds. That is, funds shall not be wired or paid until verification has been made that the Trustee received the securities or collateral.

Diversification

The District shall diversify its investments by security type and institution. The asset mix of the District's portfolio is expressed in terms of maximum commitment so as to allow sufficient flexibility to take advantage of market considerations within the context of this policy. The asset mix requirements are as follows:

Money Market Accounts	60% (maximum)
Certificates of Deposit	25% (maximum)
U.S. Treasury Obligations	100% (maximum)
U.S. Government Securities	100% (maximum)
Repurchase Agreements	15% (maximum)
Public Funds Investment Pools	100% (maximum)
Commercial Paper	25% (maximum)
Guaranteed Investment Contracts	60% (maximum)

Maximum Maturity

To the extent possible, the District shall attempt to match its investments with anticipated cash flow requirements. Unless matched to a specific cash flow, the District shall not directly invest in securities maturing more than 36 months from the date of purchase. However, securities with a maturity of greater than 12 months shall not exceed ten percent of the total portfolio, and shall be approved by the Board before purchase.

Bond proceeds and debt service funds may be invested in securities exceeding 12 months if the maturity of such investments is made to coincide as nearly as practicable with the expected use of the funds.

Arbitrage

The Tax Reform Act of 1986 provided limitations restricting the amount of income that could be generated from the investment of tax-exempt General Obligation Bond proceeds and debt service

income. The arbitrage rebate provisions require that the District compute earnings on investment from each issue of bonds on an annual basis to determine if a rebate is required. To determine the District's arbitrage position, the District is required to perform specific calculations relative to the actual yield earned on the investment of the funds and the yield that could have been earned if the funds had been invested at a rate equal to the yield on the bonds sold by the District. The rebate provision states that periodically (not less than once every five years, and not later than 60 days after the maturity of the bonds), the District is required to pay the U.S. Treasury a rebate of excess earnings based on the District being in a positive arbitrage position. The Tax Reform restrictions require precision in the monitoring and recording of investments as a whole, and particularly as relates to yields and computations so as to ensure compliance. Failure to comply can dictate that the bonds become taxable, retroactively from the date of issue.

The District's investment position relative to arbitrage is the continued pursuit of maximizing the yield on applicable investments while ensuring the safety of capital and liquidity. It is a fiscally sound position to continue maximization of yield and rebate excess earnings, if necessary.

Benchmark

The District's investment strategy is a passive one, in that the majority of securities shall be purchased and held to maturity. Additionally, cash inflows and outflows shall be monitored daily. Given this strategy, the basis used by the investment officers to determine whether market yields are being achieved shall be the Two-Year U.S. Treasury Bill and the average Fed Funds rate.

Internal Control

The investment portfolio, as well as compliance with this policy, shall be reviewed quarterly by the investment committee and annually by the District's external auditor in conjunction with the annual audit of the District's financial statements.

Investment Committee

The investment committee shall review the investment strategies annually and make recommendations for revision as necessary. The investment committee includes, but is not limited to, the Superintendent, the chief financial officer, the director of finance, the budget and treasury officer, the financial advisor, Board financial audit committee (nonvoting), and up to two investment bankers.

Quality of Investment Management

Designated investment officers of the District shall participate in periodic training through courses and seminars offered by professional organizations, associations, and other independent sources approved by the investment committee to ensure the quality and capability of investment management in compliance with the Public Funds Investment Act.

Investment Training

Within 12 months after taking office or assuming duties, designated investment officers of the District shall attend at least one training session from an independent source approved either by the Board or by the investment committee advising the investment officers. This initial training must contain at least ten hours of instruction relating to their respective responsibilities under the Public Funds Investment Act. *Gov't Code 2256.008(a)*

The investment officers must also attend an investment training session not less than once in a two-year period that begins on the first day of the District's fiscal year and consists of the two consecutive fiscal years after that date, and receive not less than ten hours of instruction relating to investment responsibilities under the Public Funds Investment Act from an independent source approved by the Board or the investment committee advising the investment officers. If the District has contracted with another investing entity to invest the District's funds, this training requirement may be satisfied by having a Board officer attend four hours of appropriate instruction in a two-year period that begins on the first day of the District's fiscal year and consists of the two consecutive fiscal years after that date. *Gov't Code 2256.008(a), (b)*

Investment training shall include education in investment controls, security risks, strategy risks, market risks, diversification of investment portfolio, and compliance with the Government Code, Chapter 2256. *Gov't Code 2256.008(c)*

Reporting

Investment performance shall be regularly monitored by investment staff and reported to the Board. Month-end market prices on each security will be obtained by the Budget and Treasury Officer from a variety of nationally recognized securities databases (e.g., the Wall Street Journal, Bloomberg, etc.). These prices will be recorded in the District's portfolio database and included in all management reports where necessary as well as the District's Comprehensive Annual Financial Report.

Not less than quarterly the investment officers will submit to the Board a written report of the status of the current investment portfolio. The report must meet the requirements of Chapter 2256 of the Government Code (Public Funds Investment Act) and:

1. Describe in detail the investment position of the District on the date of the report;
2. Be prepared jointly by all investment officers of the District;
3. Be signed by each investment officer of the District;

OTHER REVENUES
INVESTMENTS

CDA
(LOCAL)

4. Contain a summary statement for each pooled fund group that states the beginning market value for the period and the ending market value for the period;
5. State the book value and market value of each separately invested asset at the end of the reporting period by the type of asset and type of fund, and type of institution;
6. Percent of portfolio by type of asset, fund, and institution will be provided;
7. State the maturity date of each separately invested asset that has a maturity date;
8. State the account or fund or pooled fund group for which each individual investment was acquired; and
9. State the compliance of the investment portfolio as it relates to the investment strategy and relevant provisions of this policy and the Public Funds Investment Act.

An independent auditor shall formally review the quarterly reports prepared under this section at least annually, and that auditor shall report the results of the review to the Board.

**Annual
Compliance
Audit**

In conjunction with the annual financial audit, a compliance audit shall be performed that includes an audit of management controls on investments and adherence to the District's established policy.

**Investment Policy
Approval**

The District's investment policy shall be adopted by resolution of the Board. The policy shall be reviewed annually and approved by the Board.

**CONSIDER APPROVAL OF THE 2018-2019 SERVICE AGREEMENT
WITH MEMORIAL HERMANN COMMUNITY BENEFIT CORPORATION**

RECOMMENDATION:

That the Board of Trustees approve the service agreement with Memorial Hermann Benefit Corporation.

IMPACT/RATIONALE:

In 2002 the District entered into an agreement with Memorial Hermann to provide a school based health clinic. Memorial Hermann provides the clinic building and staff (nurse practitioner, LVN, social worker, receptionist, and part-time dietitian) for the Lamar Consolidated High School and Terry High School feeder patterns. All services will be free of charge to students in both feeder patterns. Services include health screenings, physicals, immunizations, treatment of acute minor illnesses and injuries, health education, nutritional counseling, individual and group counseling, case management, and expert medical consultation. The District provides the space and transportation to students when needed.

Resource Person: Valerie Vogt, Chief Academic Officer
Dr. Jonathan Maxwell, Executive Director of Special Programs
Dr. Jennifer Roberts, Director of Student Support Services

Recommended for approval:



Dr. Thomas Randle
Superintendent

**AGREEMENT BETWEEN
LAMAR CONSOLIDATED INDEPENDENT SCHOOL DISTRICT (THE LAMAR CLINIC)
AND
MEMORIAL HERMANN COMMUNITY BENEFIT CORPORATION
(the “Agreement”)**

This Agreement for services is made by and between the Lamar Consolidated Independent School District (“LCISD”), 3911 Avenue I, Rosenberg, Texas 77471, and Memorial Hermann Community Benefit Corporation (‘Memorial Hermann’) a non-profit corporation organized under the Laws of the State of Texas, with offices at 909 Frostwood, Suite 2.205, Houston, Texas 77024.

WHEREAS, LCISD and Memorial Hermann desire good health for children and families;

WHEREAS, LCISD and Memorial Hermann desire to promote adequate health services for disadvantaged students through establishing a school-based health center (the “Center”);

WHEREAS, LCISD and Memorial Hermann desire to improve outcomes for children and families;

NOW THEREFORE, in consideration of the mutual promises herein contained, the parties hereto agree as follows:

I. The Program

Memorial Hermann is a community-based, not-for-profit healthcare corporation. Since 1907, the mission of the Memorial Hermann Health System and its subsidiaries such as Memorial Hermann has been to improve the health and well being of those who live in the communities they serve. LCISD had long lobbied for a school based health center to serve its uninsured and under-insured student populations. In 2003 Memorial Hermann Health Centers for Schools—Lamar Clinic began serving students facing barriers to healthcare at the Lamar feeder pattern schools. (The students and siblings of students attending Jackson Elementary are also served.) In 2012, a similar clinic began serving students at the Terry feeder pattern schools. In 2018, both clinics began serving selective populations for the district: homeless, parenting teens and their children (age 3 months and above), and uninsured ADHD students.

The Center operates year round. School nurses coordinate appointments. Center staff consists of a nurse practitioner and a licensed vocational nurse with medical supervision by a pediatrician or family practitioner. A licensed clinical social worker, receptionist, and part-time dietitian complete the staffing model. Services include health screenings, physicals, immunizations, treatment of acute minor illnesses and injuries, family planning services, some chronic care, laboratory work and prescribed pharmaceuticals associated with the visit, health education, nutritional counseling, individual and group counseling, case management and expert medical consultation.

All services are provided at no cost to students or families. Medicaid and Medicaid Managed Care are billed for eligible/enrolled students incurring covered services. No cash is collected at the center site.

A dentist and dental assistant provide screenings, cleanings, fillings, sealants, simple extractions, and education on a mobile dental van. They are at each clinic site for a month at a time, approximately four months a year. The priority for service is students facing barriers to oral healthcare access.

Referrals for services requiring more extensive medical care are made to public providers and private physicians who accept Medicaid and CHIP eligible clients. The center strives to direct children with Medicaid, CHIP, or private insurance to their primary care provider and to encourage families with the potential of insurance to apply. To assist this effort a part-time Navigator has been added to the team to work closely with the clinic staff.

2. Scope of Services

Services to be provided by Memorial Hermann:

- Pay the costs for building, installing, removing, insuring, equipping, and maintaining the Center and mobile dental van. The parties understand that in the event that this Agreement is terminated, the modular buildings and equipment purchased by Memorial Hermann will remain Memorial Hermann property.
- Provide or arrange for appropriate clinical and administrative personnel to perform the program's scope of services
- Cooperate in case management in a collaborative environment with the school nurses, counselors and social workers
- Pay salary, benefits, and liability insurance for Memorial Hermann employed staff
- Provide evidence of insurance to LCISD
- Provide or arrange for medical services to include: health education, prevention and screening; physicals; immunizations; treatment of minor acute illnesses and injuries; laboratory testing and prescribed pharmaceuticals associated with the visit; nutritional counseling; family planning services; referral and follow-up. Social work services to include: individual and group counseling and case management. Dental services to include: screenings, cleanings, fillings, sealants, simple extractions, and education.
- Provide reports to LCISD on the number of students and families served
- Dispose of biochemical waste material

Services to be provided by LCISD:

- Make available, as a key contact, the supervisor of school nurses/social workers

- Provide appropriate operational land to Memorial Hermann, at no charge, for the location of the modular center and mobile dental van
- Provide appropriate operational office space for the selective special interest populations dedicated to the entire district
- Construct and maintain ramps for wheel chair access to the Center and provide canopy (if necessary) for coverage
- Furnish the electric, gas, sanitary sewer, and water for operating the Center and dental van
- Provide bus transportation between schools served and the Center during the school year
- Refer students, with parental consent, to the Center as appropriate (typically nurses refer for medical services; counselors and social workers for counseling services)
- Provide in-services on LCISD procedures for Center staff
- Provide Center housekeeping services with the exception of biochemical waste
- Provide security to the Center consistent with the rest of the grounds
- Provide for Center staff to have access to the clinic during school holidays
- Cooperate with Memorial Hermann regarding the necessary security and protection of on-site drugs
- Cooperate in case management in a collaborative environment between the Center staff, school nurses, counselors, and social workers

3 Term of Agreement

This Agreement shall commence on September 1, 2018, and continue through August 31, 2019. This Agreement may be terminated by either party as provided in the termination section of this Agreement.

4. Termination of Agreement

Either party shall have the right to terminate this Agreement with or without cause upon providing thirty (30) days advance written notice to the other party. Neither party shall incur liability for termination of this Agreement if in compliance with this provision.

5. Reports

Memorial Hermann agrees to furnish all information, documentation, and reports reasonably requested by LCISD pertaining to services performed incident to this Agreement. Lamar Consolidated Independent School district reserves the right to perform an evaluation of these services in order to determine the benefits conferred upon LCISD. LCISD agrees to furnish student information requested by Memorial Hermann on student grades, absenteeism, and conduct so that Memorial Hermann can measure outcomes to determine the benefits conferred.

6. Relationship of Parties

Neither Memorial Hermann nor any employee or independent contractor utilized by Memorial Hermann shall be deemed for any purpose to be an employee or agent of LCISD. This Agreement does not, and shall not be construed to, create a joint venture, joint enterprise, or business partnership under Texas Law. Memorial Hermann assumes full responsibility for the actions of its employed personnel while performing any services incident to this Agreement and shall remain solely responsible for their supervision, daily direction and control, payment of salary (including withholding of income taxes and social security), injured employee or disability benefits and like requirements and obligations.

7. No Waiver of Immunity

Neither party relinquishes any immunity or defense on behalf of itself, its directors, trustees, officers, employees, or agents as a result of the execution of this Agreement and performance of the functions or obligations described herein.

8. Governing Law

This Agreement is made in Texas and shall be construed, interpreted, and governed by the laws of such state. The parties consent to the jurisdiction and venue of the courts of Harris County, Texas for any action under this Agreement.

9. Triplicate Originals

This Agreement is executed in three originals, each of which shall have the full force and effect of but one Agreement and each of which shall constitute but one and the same instrument.

10. No Assignment

No Assignment of this Agreement, or of any duty or obligation of performance hereunder, shall be made in whole or in part by either party without the prior written consent of the other party.

11. Authorization of Agreement

Each party represents and warrants to the other that the execution of this Agreement has

been duly authorized, and that this agreement constitutes a valid and enforceable obligation of such party according to its terms. LCISD agrees that Memorial Hermann may carry out some of its obligations hereunder via its parent company, Memorial Hermann Healthcare System, and that said company shall have all the rights and obligations of Memorial Hermann.

12. Notice

Any notice required to be given under the provisions of this Agreement shall be in writing and shall be duly served when it shall be hand-delivered to the addressees set out below, or shall have been deposited duly registered or certified, return receipt requested, in a United States Post Office addressed to the other party at the following addresses:

To Memorial Hermann-

Memorial Hermann Community Benefit Corporation
Attn: Ms. Deborah Ganelin
909 Frostwood, Suite 2.205
Houston, Texas 77024

To LCISD-

Lamar Consolidated Independent School District
Superintendent of Schools
3911 Avenue I
Rosenberg, Texas 774471

Any party may designate a different address by giving the other party ten days written notice in the manner provided above.

13. Section Headings

The headings of sections contained in this Agreement are for convenience only, and they shall not, expressly or by implication, limit, define, extend, or construe the terms or provisions of the sections of this Agreement.

14. Student Records

To the extent that Memorial Hermann will come into possession of student records incidental to this Agreement, Memorial Hermann agrees to comply with all requirements of the Family Educational Rights and Privacy Act. In the event that LCISD is required to furnish information of records, pursuant to the Open Records Act, Memorial Hermann shall furnish all such information and records to LCISD, and LCISD shall have the right to release such information and records, subject to patient privacy laws and state law.

15. Complete Understanding

This Agreement shall constitute the complete understanding of Memorial Hermann and LCISD and may not be modified in any manner without the express written consent of both parties.

16. No Waiver

No waiver of a breach of any provision of this Agreement shall be construed to be a waiver of any breach of any other provision. No delay in acting with regard to any breach of any provision shall be construed to be a waiver of such breach.

17. Force Majeure

Neither party shall be responsible to the other for failure to perform its responsibilities where such failure is due to causes beyond the reasonable control of the party including, but not limited to, civil disasters, labor strikes, war or civil insurrection, terrorism, and fire or other casualty.

IN WITNESS THEREOF, LCISD AND MEMORIAL HERMANN have executed this Agreement on this _____ day of _____ 2018.

MEMORIAL HERMANN

LAMAR CONSOLIDATED
INDEPENDENT SCHOOL DISTRICT

Carol Paret, Chief
Community Health Officer
Date _____

James Steenbergen, President
Board of Education
Date _____

**Approved as to Legal Form Only
On behalf of MHHS**

By: Kristin Tiller
Assistant General Counsel
Date: July 30, 2018

Kathryn Kaminski, Secretary Date
Board of Education

Thomas Randle, Ed.D. Date
Superintendent of Schools

**AGREEMENT BETWEEN
LAMAR CONSOLIDATED INDEPENDENT SCHOOL DISTRICT (THE TERRY CLINIC)
AND
MEMORIAL HERMANN COMMUNITY BENEFIT CORPORATION
(the “Agreement”)**

This Agreement for services is made by and between the Lamar Consolidated Independent School District (“LCISD”), 3911 Avenue I, Rosenberg, Texas 77471, and Memorial Hermann Community Benefit Corporation (‘Memorial Hermann’) a non-profit corporation organized under the Laws of the State of Texas, with offices at 909 Frostwood, Suite 2.205, Houston, Texas 77024.

WHEREAS, LCISD and Memorial Hermann desire good health for children and families;

WHEREAS, LCISD and Memorial Hermann desire to promote adequate health services for disadvantaged students through establishing a school-based health center (the “Center”);

WHEREAS, LCISD and Memorial Hermann desire to improve outcomes for children and families;

NOW THEREFORE, in consideration of the mutual promises herein contained, the parties hereto agree as follows:

I. The Program

Memorial Hermann is a community-based, not-for-profit healthcare corporation. Since 1907, the mission of the Memorial Hermann Health System and its subsidiaries such as Memorial Hermann has been to improve the health and well being of those who live in the communities they serve. LCISD had long lobbied for a school based health center to serve its uninsured and under-insured student populations. Since 2003 Memorial Hermann Health Centers for Schools—Lamar Clinic has served students facing barriers to healthcare at the Lamar feeder pattern schools. In 2012 Memorial Hermann Health Centers for Schools—Terry Clinic began serving uninsured and Medicaid students, as well as insured students facing barriers to health care within the Terry feeder pattern schools. In 2018, both clinics began serving selective populations for the district: homeless, parenting teens and their children (age 3 months and above), and uninsured ADHD students.

The Center operates year round. School nurses coordinate appointments. Center staff consists of a nurse practitioner and a licensed vocational nurse with medical supervision by a pediatrician or family practitioner. A licensed clinical social worker, receptionist, and part-time dietitian complete the staffing model. Services include health screenings, physicals, immunizations, treatment of acute minor illnesses and injuries, family planning services, some chronic care, laboratory work and prescribed pharmaceuticals associated with the visit, health education, nutritional counseling, individual and group counseling, case management and expert medical consultation.

All services are provided at no cost to students or families. Medicaid and Medicaid Managed Care are billed for eligible/enrolled students incurring covered services. No cash is collected at the center site, and families are not billed.

A dentist and dental assistant provide screenings, cleanings, fillings, sealants, simple extractions, and education on a mobile dental van. They are at each clinic site for a month at a time, approximately four months a year. The priority for service is students facing barriers to oral healthcare access.

Referrals for services requiring more extensive medical care are made to public providers and private physicians who accept Medicaid and CHIP eligible clients. The center strives to direct children with Medicaid, CHIP, or private insurance to their primary care provider and to encourage families with the potential of insurance to apply. To assist this effort a part-time Navigator has been added to the team to work closely with the clinic staff.

2. Scope of Services

Services to be provided by Memorial Hermann:

- Pay the costs for building, installing, removing, insuring, equipping, and maintaining the Center and mobile dental van. The parties understand that in the event that this Agreement is terminated, the modular buildings and equipment purchased by Memorial Hermann will remain Memorial Hermann property.
- Provide or arrange for appropriate clinical and administrative personnel to perform the program's scope of services
- Cooperate in case management in a collaborative environment with the school nurses, counselors and social workers
- Pay salary, benefits, and liability insurance for Memorial Hermann employed staff
- Provide evidence of insurance to LCISD
- Provide or arrange for medical services to include: health education, prevention and screening; physicals; immunizations; treatment of minor acute illnesses and injuries; laboratory testing and prescribed pharmaceuticals associated with the visit; nutritional counseling; family planning services; referral and follow-up. Social work services to include: individual and group counseling and case management. Dental services to include: screenings, cleanings, fillings, sealants, simple extractions, and education.
- Provide reports to LCISD on the number of students and families served
- Dispose of biochemical waste material

Services to be provided by LCISD:

- Make available, as a key contact, the supervisor of school nurses/social workers
- Provide appropriate operational land to Memorial Hermann, at no charge, for the location of the modular center and mobile dental van
- Provide appropriate operational office space for the selective special interest populations dedicated to the entire district
- Construct and maintain ramps for wheel chair access to the Center and provide canopy (if necessary) for coverage
- Furnish the electric, gas, sanitary sewer, and water for operating the Center and dental van
- Provide bus transportation between schools served and the Center during the school year
- Refer students, with parental consent, to the Center as appropriate (typically nurses refer for medical services; counselors and social workers for counseling services)
- Provide in-services on LCISD procedures for Center staff
- Provide Center housekeeping services with the exception of biochemical waste
- Provide security to the Center consistent with the rest of the grounds
- Provide for Center staff to have access to the clinic during school holidays
- Cooperate with Memorial Hermann regarding the necessary security and protection of on-site drugs
- Cooperate in case management in a collaborative environment between the Center staff, school nurses, counselors, and social workers

3. Term of Agreement

This Agreement shall commence on September 1, 2018, and continue through August 31, 2019. This Agreement may be terminated by either party as provided in the termination section of this Agreement.

4. Termination of Agreement

Either party shall have the right to terminate this Agreement with or without cause upon providing thirty (30) days advance written notice to the other party. Neither party shall incur liability for termination of this Agreement if in compliance with this provision.

5. Reports

Memorial Hermann agrees to furnish all information, documentation, and reports reasonably requested by LCISD pertaining to services performed incident to this Agreement. Lamar Consolidated Independent School district reserves the right to perform an evaluation of these services in order to determine the benefits conferred upon LCISD. LCISD agrees to furnish student information requested by Memorial Hermann on student grades, absenteeism, and conduct so that Memorial Hermann can measure outcomes to determine the benefits conferred.

6. Relationship of Parties

Neither Memorial Hermann nor any employee or independent contractor utilized by Memorial Hermann shall be deemed for any purpose to be an employee or agent of LCISD. This Agreement does not, and shall not be construed to, create a joint venture, joint enterprise, or business partnership under Texas Law. Memorial Hermann assumes full responsibility for the actions of its employed personnel while performing any services incident to this Agreement and shall remain solely responsible for their supervision, daily direction and control, payment of salary (including withholding of income taxes and social security), injured employee or disability benefits and like requirements and obligations.

7. No Waiver of Immunity

Neither party relinquishes any immunity or defense on behalf of itself, its directors, trustees, officers, employees, or agents as a result of the execution of this Agreement and performance of the functions or obligations described herein.

8. Governing Law

This Agreement is made in Texas and shall be construed, interpreted, and governed by the laws of such state. The parties consent to the jurisdiction and venue of the courts of Harris County, Texas for any action under this Agreement.

9. Triplicate Originals

This Agreement is executed in three originals, each of which shall have the full force and effect of but one Agreement and each of which shall constitute but one and the same instrument.

10. No Assignment

No Assignment of this Agreement, or of any duty or obligation of performance hereunder, shall be made in whole or in part by either party without the prior written consent of the other party.

11. Authorization of Agreement

Each party represents and warrants to the other that the execution of this Agreement has been duly authorized, and that this agreement constitutes a valid and enforceable obligation of such party according to its terms. LCISD agrees that Memorial Hermann may carry out some of its obligations hereunder via its parent company, Memorial Hermann Healthcare System, and that said company shall have all the rights and obligations of Memorial Hermann.

12. Notice

Any notice required to be given under the provisions of this Agreement shall be in writing and shall be duly served when it shall be hand-delivered to the addressees set out below, or shall have been deposited duly registered or certified, return receipt requested, in a United States Post Office addressed to the other party at the following addresses:

To Memorial Hermann-

Memorial Hermann Community Benefit Corporation
Attn: Ms. Deborah Ganelin
909 Frostwood, Suite 2.205
Houston, Texas 77024

To LCISD-

Lamar Consolidated Independent School District
Superintendent of Schools
3911 Avenue I
Rosenberg, Texas 774471

Any party may designate a different address by giving the other party ten days written notice in the manner provided above.

13. Section Headings

The headings of sections contained in this Agreement are for convenience only, and they shall not, expressly or by implication, limit, define, extend, or construe the terms or provisions of the sections of this Agreement.

14. Student Records

To the extent that Memorial Hermann will come into possession of student records incidental to this Agreement, Memorial Hermann agrees to comply with all requirements of the Family Educational Rights and Privacy Act. In the event that LCISD is required to furnish information of records, pursuant to the Open Records Act, Memorial Hermann shall furnish all such information and records to LCISD, and LCISD shall have the right to release such information and records, subject to patient privacy laws and state law.

15. Complete Understanding

This Agreement shall constitute the complete understanding of Memorial Hermann and LCISD and may not be modified in any manner without the express written consent of both parties.

16. No Waiver

No waiver of a breach of any provision of this Agreement shall be construed to be a waiver of any breach of any other provision. No delay in acting with regard to any breach of any provision shall be construed to be a waiver of such breach.

17. Force Majeure

Neither party shall be responsible to the other for failure to perform its responsibilities where such failure is due to causes beyond the reasonable control of the party including, but not limited to, civil disasters, labor strikes, war or civil insurrection, terrorism, and fire or other casualty.

IN WITNESS THEREOF, LCISD AND MEMORIAL HERMANN have executed this Agreement on this _____ day of _____ 2018.

MEMORIAL HERMANN

LAMAR CONSOLIDATED
INDEPENDENT SCHOOL DISTRICT

Carol Paret, Chief
Community Health Officer
Date: _____

James Steenberg, President
Board of Education
Date: _____

Approved as to Legal Form Only
On behalf of MHHS
Kristin Tiller
By: Kristin Tiller
Assistant General Counsel
Date: July 30, 2018

Kathryn Kaminski, Secretary Date
Board of Education

Thomas Randle, Ed.D. Date
Superintendent of Schools

CONSIDER RATIFICATION OF DONATIONS TO THE DISTRICT

RECOMMEDATION:

That the Board of Trustees ratify donations to the District.

IMPACT/RATIONALE:

Policy CDC (Local) states that the Board of Trustees must approve any donation with a value in excess of \$5,000.

PROGRAM DESCRIPTION:

Austin PTO donated \$5,901.13 to purchase 4 round 46” outdoor tables and included installation at Austin Elementary School.

Bentley Elementary PTA donated \$35,888.50 to purchase a marquee for Bentley Elementary School.

Campbell Elementary PTO donated \$6,092 to purchase a sound system for Campbell Elementary School.

Escal Institute of Advanced Technologies donated \$10,000 to Common Threads.

The Sanctuary Fellowship donated \$6,000 to Common Threads.

Frost Elementary PTO donated \$6,650 to the math program to support math fluency at Frost Elementary School.

Friends of Huggins donated \$23,000 to purchase 30 laptops and cart at Huggins Elementary School.

Pegasus Schools, Inc. donated \$5,000 to purchase books for educational enhancement at Wertheimer Middle School.

Recommended for approval:



Dr. Thomas Randle
Superintendent

**CONSIDER APPROVAL OF RESOLUTION PROCLAIMING
CHILDHOOD CANCER AWARENESS MONTH**

RECOMMENDATION:

That the Board of Trustees approve the attached resolution proclaiming September 2018 as “Childhood Cancer Awareness Month” in the Lamar Consolidated Independent School District.

IMPACT/RATIONALE:

Families, caregivers, charities, organizations and research groups across the United States observe September as Childhood Cancer Awareness Month. Every year, approximately 16,000 children in the U.S. under the age of 21 are diagnosed with cancer; 1/4 of them will not survive the disease.

Submitted by: Mike Rockwood, Chief of Staff

Recommended for approval:



Dr. Thomas Randle
Superintendent of Schools

Resolution

Whereas, in the United States almost 16,000 children under the age of 21 are diagnosed with cancer every year; approximately one quarter of whom will not survive the disease; and

Whereas, cancer is the leading cause of death by disease among Texas children between infancy and age 19; and

Whereas, an estimated 1,600 children aged 19 and younger in Texas were diagnosed with cancer; and

Whereas, the objective of Childhood Cancer Awareness Month is to put a spotlight on the types of cancer that largely affect children, survivorship issues and help raise funds for research and family support;

Therefore, the Board of Trustees of the Lamar Consolidated Independent School District declares September 2018, as

Childhood Cancer Awareness Month in Lamar CISD

and encourages members of our community to reaffirm their commitment to fighting this terrible disease.

August 16, 2018



James Steenbergen, President

Kathryn Kaminski, Secretary

**CONSIDER APPROVAL OF RESOLUTION PROCLAIMING
HISPANIC HERITAGE MONTH**

RECOMMENDATION:

That the Board of Trustees approve the attached resolution proclaiming September 15 – October 15, 2018 as “Hispanic Heritage Month” in the Lamar Consolidated Independent School District.

IMPACT/RATIONALE:

September 15 – October 15 was designated by presidential proclamation as the month to celebrate the rich heritage of Hispanic Americans and the many contributions they have made to American culture.

Hispanic Heritage Month begins on September 15, the anniversary of independence for five Latin American countries—Costa Rica, El Salvador, Guatemala, Honduras and Nicaragua. In addition, Mexico declared its independence on September 16 and Chile on September 18.

Submitted by: Mike Rockwood, Chief of Staff

Recommended for approval:



Dr. Thomas Randle
Superintendent of Schools

Resolution

Whereas, September 15 is the Anniversary of Independence Day for five Latin American Countries, and is celebrated as a major cultural event by Hispanics in this country and across the Americas; and

Whereas, it is appropriate at this time to recognize the rich heritage and the significant contributions to American life by persons of Hispanic ancestry; and

Whereas, schools are in a unique position to share an appreciation of Hispanics among children from all races and backgrounds; and

Whereas, Lamar CISD schools commemorate Hispanic Heritage Month with special activities and observances;

Therefore, the Board of Trustees of the Lamar Consolidated Independent School District declares September 15 – October 15, 2018 as

Hispanic Heritage Month in Lamar CISD

and encourages members of our community to share in this celebration of our diverse American heritage.

August 16, 2018



James Steenbergen, President

Kathryn Kaminski, Secretary

**CONSIDER APPROVAL OF NOMINATION OF CANDIDATE FOR POSITIONS
ON THE TEXAS ASSOCIATION OF SCHOOL BOARDS (TASB)
BOARD OF DIRECTORS**

RECOMMEDATION:

That the Board of Trustees approve the nomination of _____ for Position 4A and _____ for Position 4C on the Texas Association of School Boards (TASB) Board of Directors.

IMPACT/RATIONALE:

From July 3, 2018 to August 29, 2018, active member school boards may endorse a nominated individual from their TASB Region.

PROGRAM DESCRIPTION:

The TASB Board of Directors is charged with carrying out the policies established by the Delegate Assembly of the Association. The individual Director is expected to attend five meetings of the Board each year with one of the meetings being at the same time as the annual state convention in the fall. In addition, the Director will be asked to serve on a standing committee that will meet on an as-needed basis, normally in conjunction with a Board meeting.

Recommended for approval:



Dr. Thomas Randle
Superintendent

**CONSIDER APPROVAL OF CENTERPOINT ENERGY FACILITIES EXTENSION
AGREEMENT AND BLANKET EASEMENT FOR CULVER ELEMENTARY SCHOOL**

RECOMMENDATION:

That the Board of Trustees approve the CenterPoint Energy facilities extension agreement and blanket easement for the installation of electric service at Culver Elementary School in the amount of \$6,200 and authorize the Board President to execute the agreement documents.

IMPACT/RATIONALE:

The facilities extension agreement and blanket easement are required to be executed for CenterPoint Energy to provide electric service for Culver Elementary School.

These funds were allocated within the 2014 Bond Budget.

PROGRAM DESCRIPTION:

Upon approval, the Board President will execute the agreement and easement documents and CenterPoint Energy will begin design and installation of the permanent electrical service for Culver Elementary School.

Submitted By: Leslie Haack, Deputy Superintendent of Support Services
Kevin McKeever, Executive Director of Facilities & Planning
Steve Hoyt, Vanir/Rice & Gardner Consultants, Inc., A Joint Venture

Recommended for approval:



Dr. Thomas Randle
Superintendent

CenterPoint Energy Houston Electric, LLC
Applicable: Entire Service Area

(6-2012)

CNP 8038

6.3 AGREEMENTS AND FORMS

6.3.1 FACILITIES EXTENSION AGREEMENT

This Facilities Extension Agreement is entered into by and between Lamar Consolidated Independent School District, herein called "Retail Customer" and CenterPoint Energy Houston Electric, LLC, herein called "Company" (hereinafter referred to as Agreement) for the construction, extension, installation, modification, repair, upgrade, conversion, relocation, de-energization or removal of Company's Delivery System, including temporary facilities (hereinafter referred to as facilities extension or extension), as described herein.

This Agreement covers the facilities extension to Retail Customer location at 3131 Learning Tree Lane, Rosenberg, Texas 77471.

The Company agrees to accept payment of \$6,200.00 Dollars to be paid by the Retail Customer, as a Non-Refundable Construction Payment in connection with the Retail Customer request to extend Company facilities to the above described location as follows: For underground service in accordance with the Company's Terms and Conditions package Job # 85225889. The cost is based on the Company utilizing its standard installation equipment. The cost does not include any overtime premiums. This agreement includes no cost for the extension, modification or removal of the existing overhead facilities. Please contact the Company's respective Service Center representative for any additional costs that may be associated with this project.

- Unless otherwise stated by Company in writing, the Non-Refundable Construction Payment amount above is valid for twelve months.

In consideration of said Non-Refundable Payment, to be paid to Company by Retail Customer prior to commencement of construction, Company agrees to install and operate lines and equipment necessary to distribute electric service to the identified location under the following General Conditions:

- Company shall at all times have title to and complete ownership and control over facilities installed by Company.
- Retail Customer must make satisfactory payment arrangements (if payment is required to extend Company facilities) and sign and return this Agreement before Company can proceed with the requested extension.

CenterPoint Energy Houston Electric, LLC
Applicable: Entire Service Area

(6-2012)
CNP 8038

- Extension of service facilities is contingent on acquisition of all necessary easements and rights of way.

Nothing herein contained within this Agreement shall be construed as a waiver or relinquishment by Company of any right that it has or may hereafter have to discontinue service for or on account of default in the payment of any bill owing or to become owing thereafter for any other reason or cause stated in Company's Tariff.

This Agreement shall not be binding upon Company unless and until it is signed by an authorized representative of the Company.

CenterPoint Energy Houston Electric, LLC

Lamar Consolidated Independent School District

Retail Customer

By _____

By _____

Frank De Leon

Signature

James Steenbergen

Name printed or typed

Name printed or typed

Title Senior Engineering Specialist

Title Board President

Date June 8, 2018

Date August 16, 2018

**TERMS AND CONDITIONS
UNDERGROUND ELECTRIC SERVICE**

FOR

**LAMAR CONSOLIDATED INDEPENDENT SCHOOL DISTRICT
Thomas R. Culver, III Elementary School
3131 Learning Tree Lane, Rosenberg, Texas 77471**

Job #85225889

**CenterPoint Energy
Major Underground Projects
P. O. Box 1700; Houston, Texas 77251-1700**

REFERENCE LAMAR CONSOLIDATED INDEPENDENT SCHOOL DISTRICT DRAWINGS:

Site Plan	Drawing #:	<u>E1.01</u>	Received:	<u>December 13, 2017</u>
Utility Plan	Drawing #:	<u>C1.02, C3.01</u>	Received:	<u>February 14, 2018</u>
Electrical One-Line	Drawing #:	<u>E6.01</u>	Received:	<u>December 13, 2017</u>
Load Analysis	Drawing #:	<u>E6.01</u>	Received:	<u>December 13, 2017</u>

REFERENCE CENTERPOINT ENERGY SPECIFICATIONS:

Service Standards	:	May 1, 2016
Emergency Generators	:	007-231-82
Ready-Mix Concrete	:	007-221-01
Harmonic Distortion	:	007-231-83

Reviewed And Agreed To By: _____ Board President _____ 08/16/2018
Signature Title Date

James Steenbergen

 Print Name

If this Terms and Conditions package is signed by anyone other than an official from **Lamar Consolidated Independent School District**, it will not be considered valid. A valid signature will be considered an acceptance of all information contained within this Terms and Conditions package.

						CenterPoint Energy Houston, Texas		
						WRITTEN	FD	6/8/2018
						CHECKED	AAO	6/8/2018
						APPROVED	AAO	6/8/2018
							SHEET 1 OF 17 SHEETS	
NO.	DATE	ITEMS REVISED	BY	CH	APP	PM 4342		

GENERAL

- A. These Terms and Conditions are for a service arrangement for Lamar Consolidated Independent School District. Lamar Consolidated Independent School District and/or its contractors/representatives are herein referred to as the Customer.
- B. Service to be provided by CenterPoint Energy (CNP) from a 750 kVA, 12.47 kV - 480Y/277 V, three phase, four wire, pad mounted transformer.
- C. The CNP Major Underground Projects (MUG) representative is Frank De Leon at 713-207-4941 or frank.deleon@centerpointenergy.com.

The CNP Service Area Consultant is Enrique Ramon at 281-341-4931.
- D. The Customer must comply with all CNP Service Standards, the National Electrical Code, the National Electrical Safety Code, all Occupational Safety and Health Administration (OSHA) requirements, the International Building Code and all local governing body codes.
- E. During installation of CNP equipment, CNP will make every effort to preserve the Customer's landscaping, parking areas, or other facilities. However, any cost that has been quoted to the Customer does not include any special replacements or repairs to these items. The Customer shall be solely responsible for any expenses associated with replacements or repairs to its facilities.
- F. The service arrangement outlined in these Terms and Conditions is based on the Customer drawings referenced on page 1. Any changes in the design as illustrated in the referenced drawings may impact CNP's ability to meet the Customer's requested service date.
- G. Any changes, additions, deletions, rearrangements, relocations, rerouting, reduction of clearances, etc., of the Customer's and/or CNP's service facilities illustrated in these Terms and Conditions shall have MUG's approval and may require a revised Terms and Conditions. It is the Customer's responsibility to coordinate the location of all Customer installed facilities outlined in these Terms and Conditions with all other structures and/or appurtenances not shown in the referenced drawings.
- H. Contact the MUG representative concerning Customer drawing revisions, information submission, questions, Terms and Conditions revision requests, etc.
- I. Hard copy submittals may be mailed to the MUG representative (address – 3000A Harrisburg Blvd. – Houston, Texas 77003). Electronic submittals may be e-mailed to the MUG representative. The MUG representative will; “approve the submittals”, “approve the submittals as noted” or “not approve the submittals”. The Customer shall not install any item that requires CNP approval before receiving an official approval from MUG. CNP shall not be responsible for any installed item that has not received MUG approval.

SERVICE CONNECTION

- A. The Customer's maximum number of secondary cables that can be terminated in CNP's pad mount transformer is 8-750 MCM cables per phase. The Customer shall advise the MUG representative, about the type, size and number of secondary conductors. Ampacity equivalent sets of cable must be individually approved by the MUG representative prior to installation by the Customer. If the Customer's cable requirements exceed this specified maximum limit, it cannot be served directly from the pad mounted transformer. The Customer shall then install, own, and maintain a cable tap box (CTB) (See Section D).
- B. On installations not utilizing a CTB, the Customer shall furnish, own, and maintain all secondary service conduit and cable underground into the secondary opening of the transformer pad. Secondary conductors shall be extended a minimum of seven feet (7') above the transformer pad. **The Customer shall not install the secondary cables until after the transformer has been set. CNP will terminate the secondary cables in the transformer.**
- C. To accommodate future expansion, the Customer may install up to 14-4" secondary conduits into the transformer pad.
- D. On installations utilizing a CTB, CNP shall furnish, own, install and terminate the secondary cable from the transformer to the CTB at the Customer's expense. The Customer shall furnish, install, own and maintain the CTB, the CTB pad, and 14-4" conduits from the secondary opening of the transformer pad to the CNP side of the CTB pad. The Customer shall install and terminate the secondary cable from its side of the CTB to its switchgear. Typical three-phase CTB drawings are available upon request. The Customer shall submit three (3) drawings of the proposed CTB to the MUG representative for approval prior to fabrication.
- E. The initial available short circuit current is 16,957 amperes symmetrical, with an X/R ratio of 7.5.
- F. The ultimate available short circuit current is 57,828 amperes symmetrical, with an X/R ratio of 10.5.
- G. Customers receiving electrical service from multiple sources will be required to install a permanent plaque or directory at each source in accordance with Article 230.2 of the National Electrical Code (NEC). These plaques are to signify that there is more than one electrical service to the building. The Customer shall keep the power from each source separate throughout its entire electrical system. This requirement is for the life of the service.
- H. A protective device coordination study for the Customer's service relative to CNP's protective devices may be requested by contacting the MUG representative.

ACCESS

The Customer must provide a twelve foot (12') minimum width, fourteen foot (14') minimum vertical clearance, all weather, vehicle access road designed for HS-20-44 loading as recognized by the American Association of State Highway Officials (AASHO), for CNP personnel and equipment ten feet (10') past the side of the proposed pad mounted equipment location. In addition, the area adjacent to the pad must be designed for HS-20-44 loading to allow for outrigger placement. If the access road and the pad mounted equipment location have not been completed and passed final inspection (see Final Inspection, page 7) at the time the Customer requests the equipment be set, the equipment can only be set under the following conditions.

- A. MUG has determined that the access route is dry and readily accessible to CNP's normal installation equipment.
- B. The Customer shall be responsible for all expenses associated with the repair and/or replacement of CNP pad mounted equipment damaged by additional construction activity. Damage to CNP equipment may result in delays to the Customer's requested service date.
- C. CNP will not complete the underground construction (i.e. pulling & terminating cable, energizing the service, etc.) until the access road and pad mounted equipment location have passed final inspection (see Final Inspection, page 7).

The Customer must provide a thirty two foot (32') minimum vertical clearance over all equipment pads for CNP trucks and equipment.

The Customer must maintain these requirements for the life of the service.

CNP will utilize the Customer's parking and driveway facilities for the required access.

EMERGENCY GENERATION AND SECONDARY LOAD TRANSFER

Customer installed Emergency Generators and/or Secondary Load Transfer schemes shall meet the requirements of the CNP Specification on Customer Emergency Generation and Secondary Load Transfer, Specification 007-231-82, latest revision (attached). This requirement is for the life of the service.

Generator exhaust must be located and/or directed away from CNP's equipment.

HARMONIC DISTORTION

The Customer shall meet the requirements of the CNP Specification on Limitation of Harmonic Distortion on the Distribution System, Specification 007-231-83, latest revision (available upon request). This requirement is for the life of the service.

METERING

- A. The Customer’s metering arrangement must comply with CNP Service Standards, Section 400 or 500 as applicable.
- B. The metering current and potential transformers (CT’s and PT’s) will be installed in the secondary compartment of the transformer provided all service from the transformer is through one meter. If all the services are not through one meter, the Customer shall inform the MUG representative, so that alternate metering provisions can be arranged (separate CT and PT cans as required for each service).
- C. All Retail Customers must be metered separately.
- D. Meter Room and/or Modular Meter installations must have CNP written approval prior to the purchase/installation of materials/equipment. The Customer must submit applicable drawings to the MUG representative for approval.

FACILITIES INSTALLED BY THE CUSTOMER

All facilities are to be installed per the attached construction specifications. The Customer or its contractor is to request a preconstruction meeting prior to starting the required underground construction by calling the number listed below.

All facilities shall be inspected by CNP after the conduit is installed, pads are formed, reinforcing rods installed, etc. but prior to the pouring of concrete. CNP recommends that the Customer complete the pouring of concrete on the day the facilities are inspected and approved. The Customer will insure that all inspected and approved facilities remain in the approved condition until the concrete pour has been completed. If there is damage to the inspected and approved facilities prior to the pouring of concrete, the facilities must be re-inspected by CNP before the Customer begins the pouring of concrete. CNP reserves the right to require the Customer to break out any unapproved concrete pours at its expense.

CNP will make a reasonable attempt to complete all inspection requests. To ensure that inspection requests can be fulfilled, they should be made prior to 5 p.m. the business day before the requested inspection to Major Underground Projects at <http://www.centerpointenergy.com/en-us/pages/mugform.aspx>. Job # 85225889 must be provided as the inspection identification number.

PRECAST MANHOLES

CNP will allow the Customer the option to install either poured-in-place or approved precast manholes. The use of precast manholes is approved for all locations where the vehicular loading does not exceed AASHO HS-20-44 Highway Loading (72,000 pounds).

CNP’s current approved suppliers are Oldcastle Precast, 13600 South Wayside Road, Houston, Texas 77048, (713) 934-7900 and Locke Solutions, 7600 S. Santa Fe Drive, Houston, Texas 77061, (832) 804-7062. Foterra Pipe and Precast, 11201 FM 529, Houston, Texas 77041, (713) 538-9321 has been approved for supplying small precast manholes. **Three (3) copies of the supplier’s drawing must be submitted to the Engineering contact, for approval prior to procurement and/or installation.**

CNP also recommends the installation of the required duct bell terminators by the manhole supplier on all precast manholes. Manholes are to be placed on a minimum of six inch (6")

PRECAST MANHOLES (continued)

leveled base of sand or crushed rock to insure uniform distribution of soil pressure on the floor. CNP must inspect this requirement prior to the installation of the manhole inside the exposed pit.

DUCTBANK INSTALLATION

All proposed conduit for CNP's use is to be installed in straight runs, unless otherwise indicated on CNP drawings. Any conduit bends must be installed with a twenty foot (20') minimum radius, unless indicated otherwise on CNP drawings. Conduit turn-ups into any equipment pad and/or pole pedestal must have a minimum five foot (5') radius. Any deviations from these requirements shall have written approval from the MUG representative prior to installation.

During installation, the minimum depth for a conduit run must be referenced to the final grade.

The Customer is to delay installation of approximately the last twenty feet (20') of the conduit run and the pole pedestal to any terminal pole until the pole has been set by CNP. Before trenching to the base of any terminal pole, the Customer must securely brace the pole. The Customer must request staking and setting of any terminal pole by contacting the Service Area Consultant.

The Customer must provide a jet line in each conduit installed. This jet line shall extend a minimum of seven feet (7') beyond the end of each conduit.

For installations not utilizing a blanket easement document (see Easement Instrument section, page 7), the Customer shall also install a #14 American Wire Gage (AWG) or larger aluminum or copper 600 volt insulated conductor in one of the conduits. The conductor must be electrically continuous. For manhole installations, the electrically continuous conductor must also be looped through each manhole lid and tied to a concrete insert in the neck of each manhole. This conductor is to facilitate surveying of the duct bank by CNP. The duct bank cannot be surveyed until this conductor is installed as prescribed. The Customer must take adequate measures to assure the conductor will be in place until all necessary surveying is completed. After surveying of the duct bank is completed, but prior to CNP installing any primary cable, the Customer may retrieve its conductor at its option.

Conduit ends shall be plugged with a duct cap or other type capping device. The use of rags to plug conduits is not acceptable. If the conduit is installed in stages, the Customer must keep each section of conduit capped until the new section is installed. If, prior to CNP using any conduit, the conduit is found to be blocked, the Customer will be responsible, at its expense, for removing the obstruction.

CLEARANCES

Final approval for the location of the pad mount equipment and/or other proposed electrical installation is contingent upon proper clearance, as determined by CNP, from cooling towers, vents, buildings, structures, etc., and other underground utilities. It is in the Customer's and CNP's best interest to have all service equipment in a contamination-free environment to avoid unscheduled outages and/or premature equipment failures. Therefore, prior to any construction, the Customer shall inform the MUG representative of any existing or future contamination or pollutants which may affect the equipment so that necessary clearances can be secured.

The MUG representative shall be notified promptly if the Customer intends to install any obstructions such as walls, hedges, bushes, trees, etc., around the transformer and/or any associated equipment so that additional clearances and access can be secured. Any proposed

CLEARANCES (continued)

enclosure surrounding CNP's equipment must be louvered, and both a profile and a cross-sectional view of the proposed louvered enclosure shall be submitted for approval prior to installation.

If, in the future, there is a problem with contamination of CNP's equipment, or proper clearances are not maintained, CNP reserves the right to relocate the equipment at the Customer's expense.

CNP will not allow other facilities to pass beneath its equipment pads. A one foot (1') minimum horizontal clearance shall be maintained between CNP pads and all other facilities.

A one foot (1') minimum vertical clearance must be maintained between CNP duct banks and all non-CNP facilities crossing the duct bank.

A five foot (5') minimum horizontal clearance must be maintained between CNP duct banks and other facilities running parallel to the duct bank. CNP will not allow joint trenching between CNP duct banks and other facilities.

ELEVATION REQUIREMENTS

The minimum elevation requirement for the top of the equipment pads shall be fifteen feet (15') above mean sea level and eighteen inches (18") above the documented 100-year floodplain. The Customer must provide equipment pads that meet these elevation requirements. The easement (minimum working clearance) around the equipment pads shall also be brought up to the above mentioned minimum elevation, as outlined on the equipment pad detail specification. The easement area surrounding the equipment pads shall not have a slope greater than 2%. The pad and minimum easement elevations (minimum working clearance) must be verified at the time installation.

VENTILATION REQUIREMENTS

Any proposed barriers or enclosures in the vicinity of the equipment pads shall maintain a minimum of 50% free air flow. Prior to construction, the Customer shall submit drawings of the proposed barriers or enclosures to MUG Projects Representative for approval.

FINAL INSPECTION

After the Customer has advised CNP that all "Customer installed" facilities pertaining to this service arrangement have been completed and inspected, a final on-site inspection will be made by a MUG representative. This final inspection will verify that all Customer installed facilities are in accordance with these Terms and Conditions. The Customer (or its contractor) and the Service Area Consultant will be advised of any needed corrections and/or changes. When all necessary corrections and/or changes have been completed, CNP's portion of the construction may begin.

EASEMENT INSTRUMENT

CNP will prepare an instrument for easements to be granted by the property owner after all installations for CNP's use have been completed according to these Terms and Conditions. The service cannot be energized until CNP has accepted the signed instrument for all easements.

EASEMENT INSTRUMENT (continued)

The Customer also has the option of signing a blanket easement document. Use of the blanket easement allows the service to be energized before the final signed instrument for all easements has been completed. The Customer may request use of the blanket easement document by contacting the MUG representative.

CNP will need access to and from the proposed easements. CNP will use these easements, as shown on the attached sketches, for the purposes of erecting, installing, operating, maintaining, replacing, inspecting and removing electrical distribution facilities. The Customer shall keep these easements free and clear of any obstructions (trees, shrubs, other structures, etc.) that may endanger or interfere with the efficiency, safety, and proper operation of the proposed facilities for the life of the service.

INDEMNIFICATION AND LIABILITY LIMITS

Indemnity: This indemnity is pursuant to Company's Tariff located on our website at www.centerpointenergy.com.

RETAIL CUSTOMER ASSUMES THE RISK OF AND SHALL INDEMNIFY COMPANY AGAINST DAMAGES FOR INJURIES OR DEATH TO PERSONS OR LOSS TO RETAIL CUSTOMER'S PROPERTY, OR TO THE PROPERTY OF COMPANY, WHEN OCCASIONED BY ACTIVITIES OF RETAIL CUSTOMER OR THIRD PARTIES ON CUSTOMER'S PREMISES, RESULTING FROM THE INSTALLATION, EXISTENCE, REPLACEMENT, OR REPAIR OF COMPANY'S UNDERGROUND FACILITIES, AND AS FURTHER PROVIDED IN THE TERMS OF "LIMITS ON LIABILITY," SECTIONS 4.2 AND 5.2 OF THIS TARIFF. NOTWITHSTANDING ANY OF THE ABOVE, THE PROVISIONS REQUIRING A RETAIL CUSTOMER TO INDEMNIFY, FULLY PROTECT, OR SAVE COMPANY HARMLESS APPLY TO A GOVERNMENTAL ENTITY AS THIS TERM IS DEFINED IN CHAPTER 2251 OF THE TEXAS GOVERNMENT CODE, TO THE EXTENT OTHERWISE CONSISTENT WITH LAW; PROVIDED, HOWEVER, THAT ANY GOVERNMENTAL ENTITY THAT IS A RETAIL CUSTOMER TO WHICH THIS SUBSECTION 2.5 APPLIES MUST TAKE NECESSARY STEPS TO ENSURE THAT THE INDEMNIFICATION REQUIREMENTS OF THIS SUBSECTION 2.5 DO NOT CREATE A "DEBT" IN VIOLATION OF ARTICLE XI, SECTION 7 OF THE TEXAS CONSTITUTION. SUCH STEPS MAY INCLUDE, BUT ARE NOT NECESSARILY LIMITED TO, A THIRD-PARTY INDEMNIFICATION IN WHICH THE CONTRACTOR PERFORMING THE WORK FOR THE GOVERNMENTAL ENTITY INDEMNIFIES THE COMPANY OR THE ESTABLISHMENT OF A SINKING FUND. *(See Governmental Entity Addendum if applicable.)*

DETAIL SKETCH

LAMBERT	SECTION	KEY MAP	FUNCTIONAL LOCATION	SCALE	CIRCUIT	ORDER NO.
4345	A2	644K		N. T. S.	BC08	

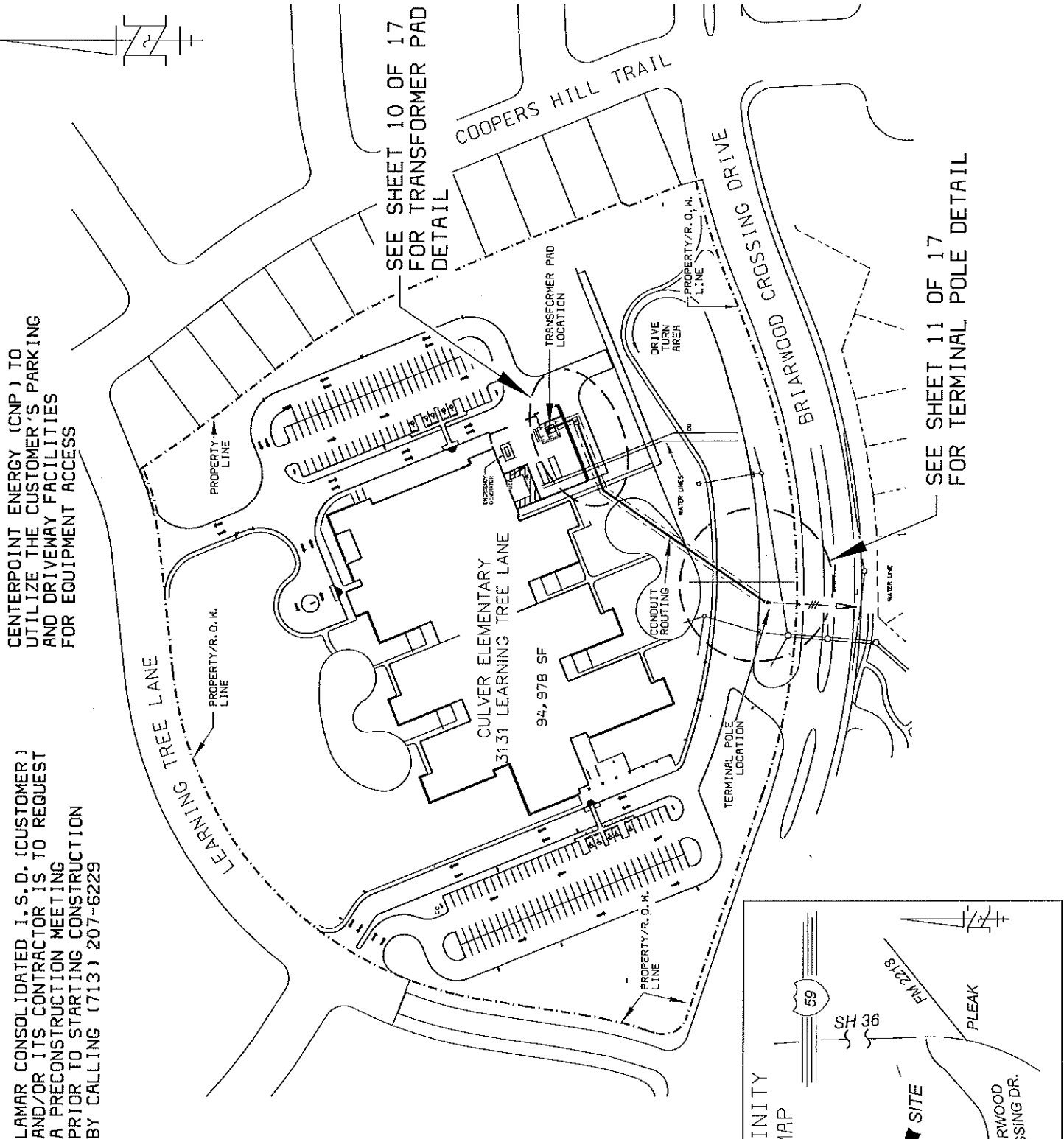

CENTERPOINT ENERGY (CNP) TO UTILIZE THE CUSTOMER'S PARKING AND DRIVEWAY FACILITIES FOR EQUIPMENT ACCESS

LAMAR CONSOLIDATED I.S.D. (CUSTOMER) AND/OR ITS CONTRACTOR IS TO REQUEST A PRECONSTRUCTION MEETING PRIOR TO STARTING CONSTRUCTION BY CALLING (713) 207-6229

SEE SHEET 10 OF 17 FOR TRANSFORMER PAD DETAIL

SEE SHEET 11 OF 17 FOR TERMINAL POLE DETAIL

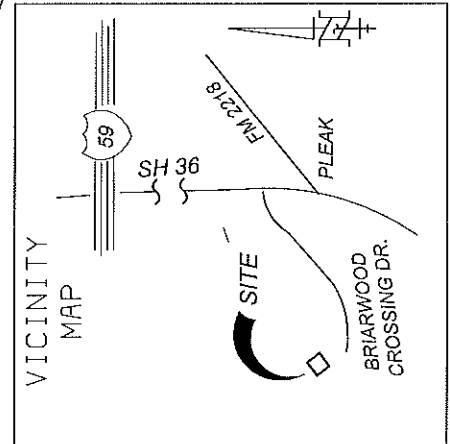

DETAIL SKETCH

LAMBERT	SECTION	KEY MAP	FUNCTIONAL LOCATION	SCALE	CIRCUIT	ORDER NO.
4345	A2	644K		N. T. S.	BC08	

NOTES

CNP WILL NOT ALLOW OTHER FACILITIES TO PASS BENEATH ITS EQUIPMENT PAD.

THE CUSTOMER MUST MAINTAIN A 5' HORIZONTAL CLEARANCE FROM PARALLEL UTILITIES, AND A 1' VERTICAL CLEARANCE WHEN CROSSING UTILITIES. (SEE NOTES 10 & 11, SHEET 12 OF 17)

REQUIRED MINIMUM 12' WIDE ALL-WEATHER HS-20-44 LOADING ACCESS ROAD 10' PAST THE SIDE OF TRANSFORMER. THIS REQUIREMENT IS FOR THE LIFE OF THE SERVICE.

METER TO BE MOUNTED ON THE SIDE OF THE TRANSFORMER BY CNP.

ALL EQUIPMENT PADS & DUCTBANK EXCLUSIVE EASEMENTS TO BE ACQUIRED BY CNP.

TRANSFORMER PAD DETAIL

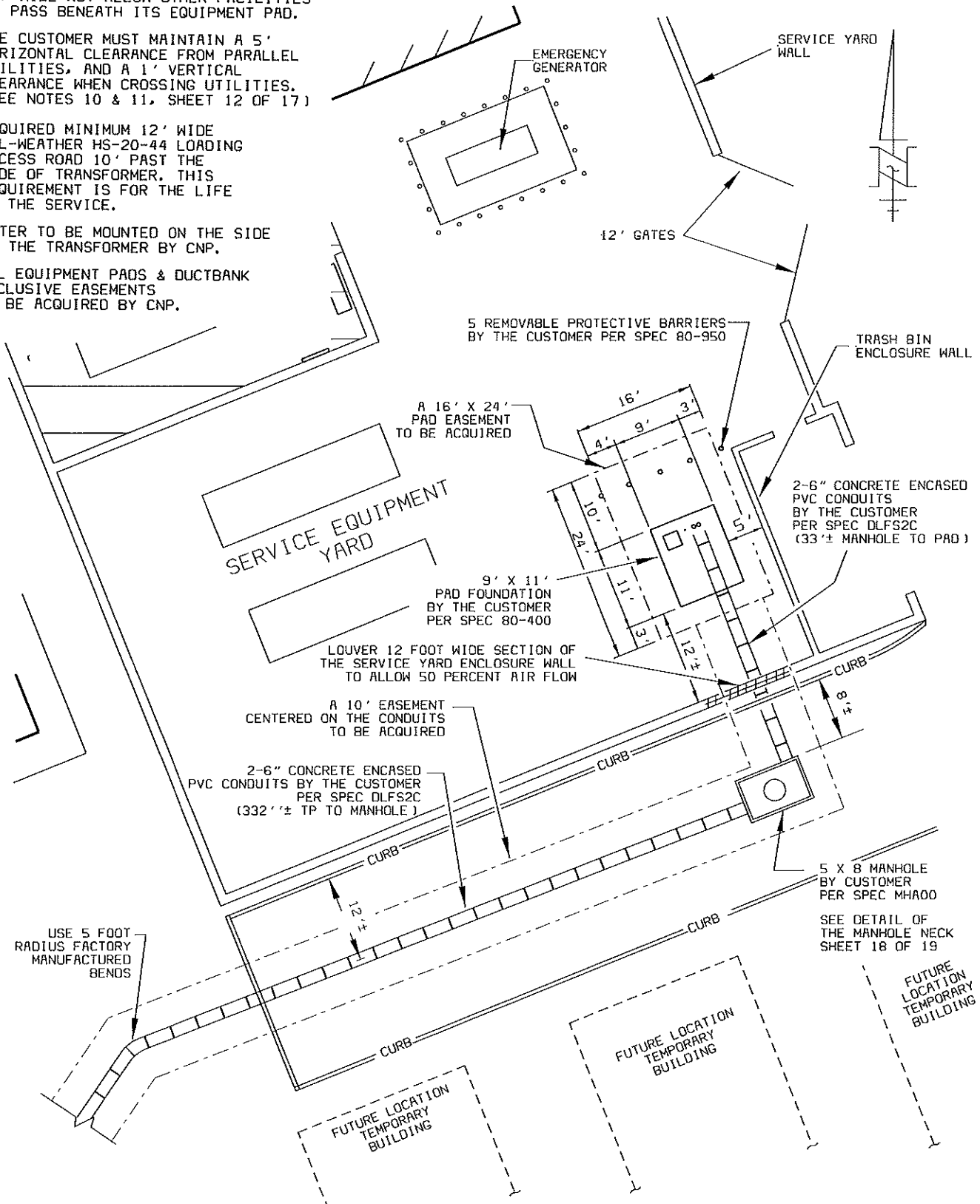

DETAIL SKETCH

LAMBERT	SECTION	KEY MAP	FUNCTIONAL LOCATION	SCALE	CIRCUIT	ORDER NO.
4345	A2	644K		N. T. S.	BC08	

TERMINAL POLE DETAIL

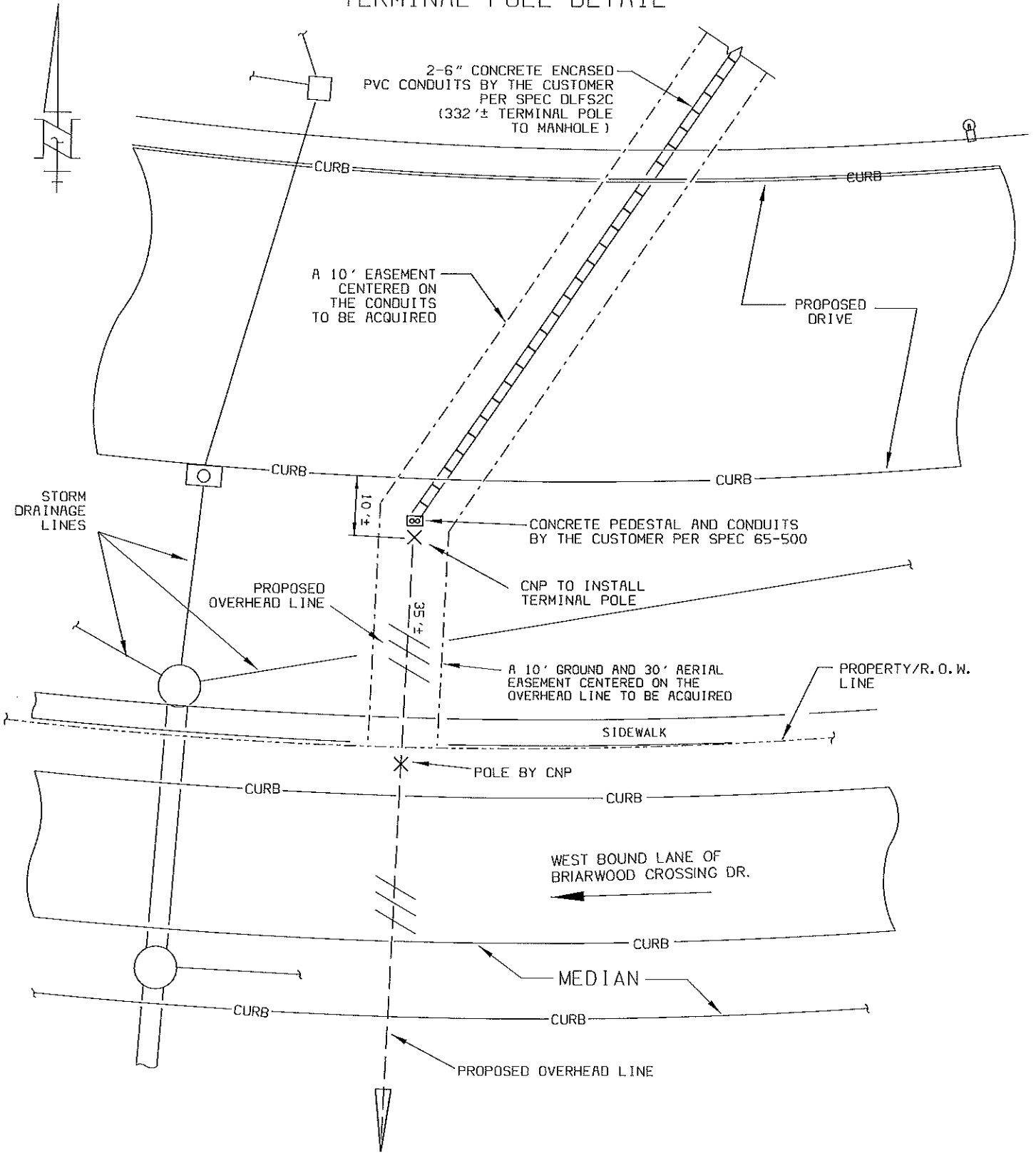

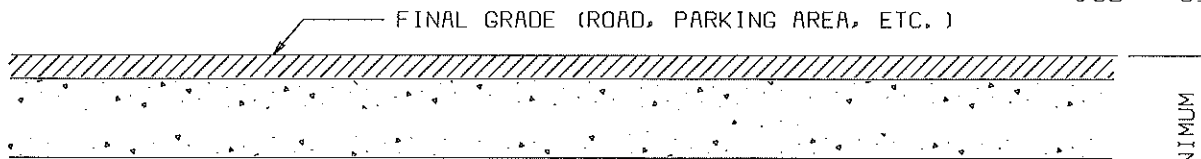
**NOTE:**

THE CUSTOMER AND/OR ITS CONTRACTOR IS TO REQUEST A PRECONSTRUCTION MEETING PRIOR TO STARTING CONSTRUCTION AT [HTTP://WWW.CENTERPOINTENERGY.COM/EN-US/PAGES/MUGFORM.ASPX](http://www.centerpointenergy.com/en-us/pages/mugform.aspx).

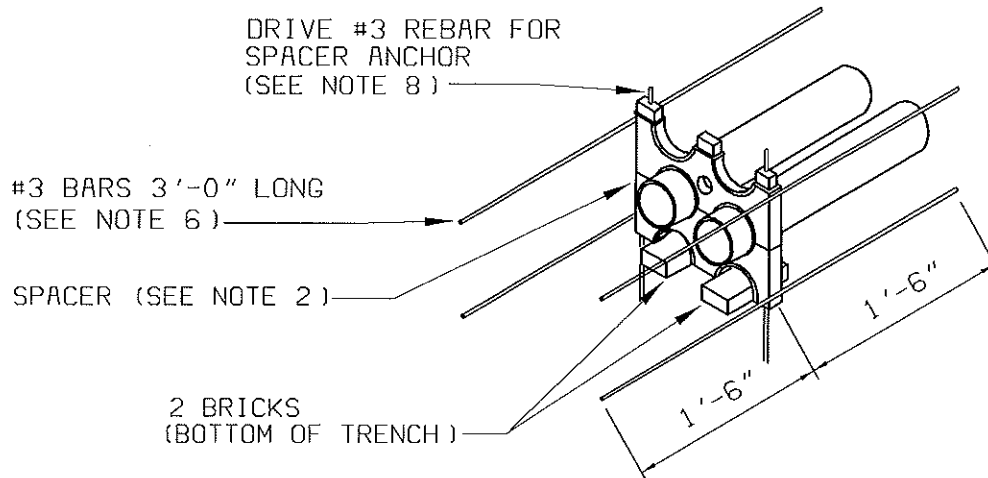
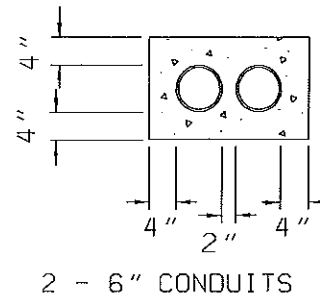
**NOTES:**

1. CONDUIT TO BE PVC, MINIMUM GRADE TYPE EB.
2. SPACERS SHOULD BE INSTALLED NOT MORE THAN 10'-0" APART.
3. CONDUITS TERMINATING AT MANHOLES SHOULD BE SLOPED 0.5% DOWN TOWARD MANHOLE.
4. ALL EXTERIOR CONCRETE COVER DIMENSIONS ARE MINIMUM.
5. CONCRETE SHALL BE IN ACCORDANCE WITH CNP SPECIFICATION 007-221-01, LATEST REVISION.
6. PLACE REINFORCING BARS IN 4 CORNERS OF THE CONCRETE WHERE SPACERS ARE USED.
7. ON COLD JOINT CONCRETE POUR USE #5 REBAR (3'-0" IN LENGTH, EXPOSED 1'-6").
8. LENGTH OF REBAR FOR SPACER ANCHOR WILL VARY PER DUCT BANK HEIGHT.
9. CONDUITS ENDS SHALL BE PLUGGED WITH A DUCT CAP OR OTHER TYPE OF CAPPING DEVICE.
10. A ONE FOOT (1') VERTICAL CLEARANCE MUST BE MAINTAINED BETWEEN CNP'S DUCTBANK AND ALL NON-CNP FACILITIES CROSSING THE DUCTBANK.
11. A FIVE FOOT (5') HORIZONTAL CLEARANCE MUST BE MAINTAINED BETWEEN CNP'S DUCTBANK AND ALL NON-CNP FACILITIES RUNNING PARALLEL TO THE DUCTBANK (JOINT TRENCHING NOT PERMITTED).
12. INSTALL JET LINE IN ALL CONDUITS AND A #14 AWG WIRE IN ONE CONDUIT.

THREE PHASE DUCTBANK
FEEDER

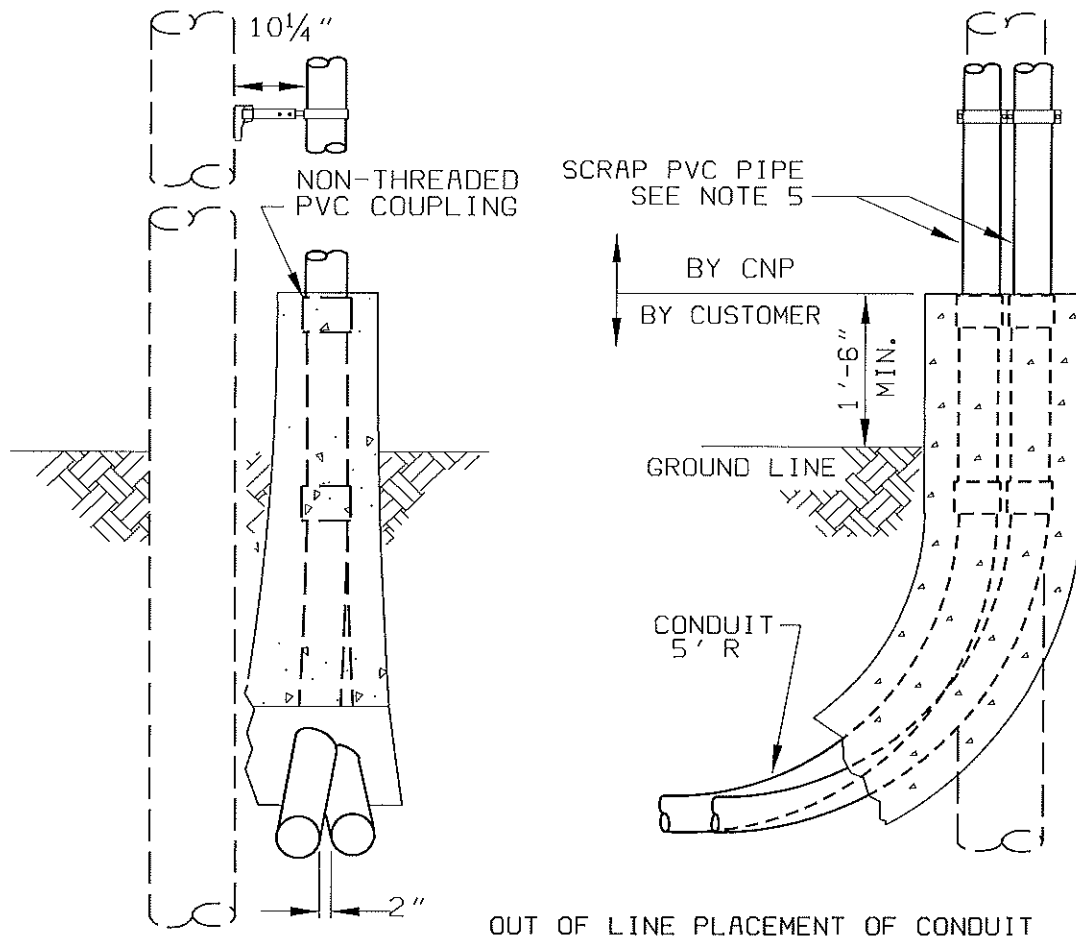

NOTES:

1. CONDUIT BENDS AT TERMINAL POLE SHALL BE PVC.
2. BRACE THE POLE SECURELY BEFORE TRENCHING.
3. INSTALL CONDUIT BENDS TO BASE OF POLE. ADD PORTIONS OF STRAIGHT CONDUIT AS NECESSARY TO OBTAIN THE PROPER HEIGHT ABOVE FINAL GRADE.
4. ATTACH COUPLING TO END OF CONDUIT.
5. INSERT, BUT DO NOT GLUE, A SHORT PIECE OF SCRAP PVC CONDUIT INTO THE TOP COUPLING. TIE CONDUIT TO BRACKET.
6. FORM AREA AROUND PEDESTAL TO THE TOP OF THE COUPLING. FORM PEDESTAL SO THAT NO CONCRETE WILL CONTACT POLE.
7. AFTER INSPECTION BY CNP, POUR CONCRETE TO TOP OF COUPLINGS.
8. ALL CONDUITS SHALL HAVE A MINIMUM 4" CONCRETE COVER.

TERMINAL POLE CONDUIT
PLACEMENT 12KV & 35 KV

BASED ON DISTRIBUTION STANDARD 65-500

030482/060807

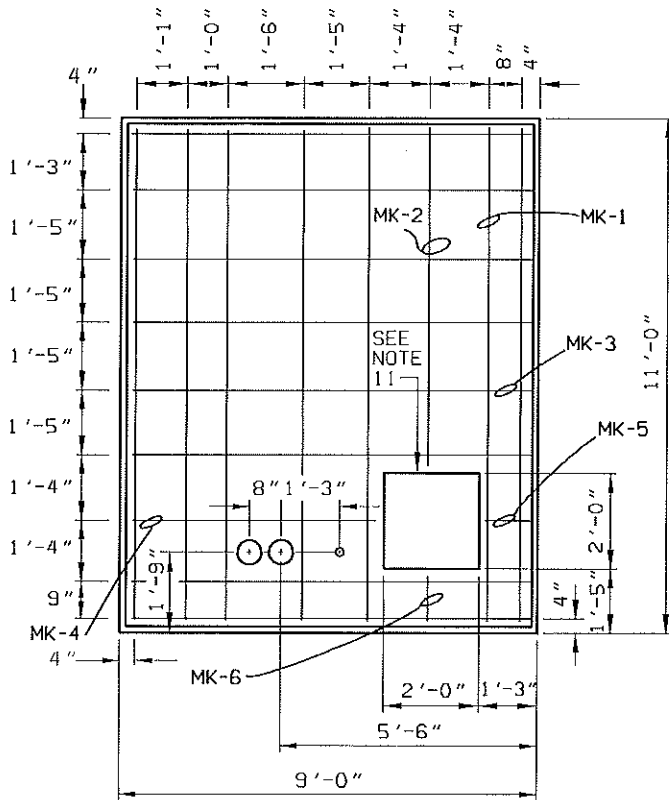

REINFORCING SCHEDULE PER FOUNDATION				
MARK	QTY.	SIZE	LENGTH	REMARKS
MK-1	14	#7	10'-6"	STRAIGHT
MK-2	2	#7	7'-0"	STRAIGHT
MK-3	16	#7	8'-6"	STRAIGHT
MK-4	2	#7	5'-3"	STRAIGHT
MK-5	2	#7	0'-9"	STRAIGHT
MK-6	2	#7	1'-0"	STRAIGHT

MATERIAL ESTIMATE PER FOUNDATION	
DESCRIPTION	QUANTITY
REINFORCING STEEL #7	636 LBS
CONCRETE (5 SACK)	5½ CU. YDS.
TYPE EB OR BETTER PVC CONDUIT, 90 DEG, 60" R	2
2" PVC CONDUIT	5 FT

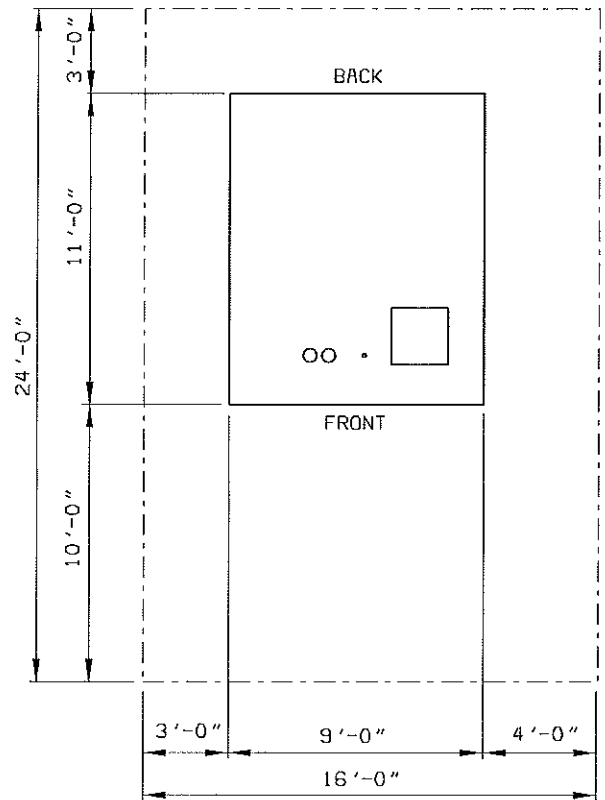
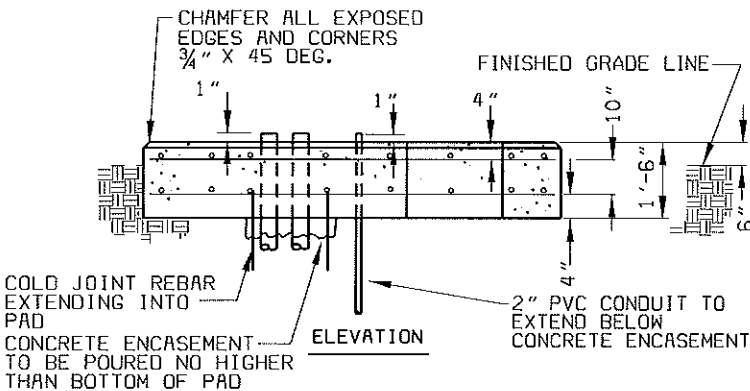

EQUIPMENT WEIGHT 43,000 LBS MAXIMUM

- NOTES:
- CONCRETE SHALL BE IN ACCORDANCE WITH CNP SPECIFICATION 007-221-01, LATEST REVISION (MINIMUM COMPRESSION IN 28 DAYS, 3000 PSI).
 - REINFORCING STEEL SHALL BE INTERMEDIATE GRADE DEFORMED BARS IN ACCORDANCE WITH A.S.T.M. SPECIFICATION A-615, GRADE 60, OR BETTER.
 - ALL SPLICES IN REINFORCING SHALL LAP A LENGTH EQUAL TO 24 BAR DIAMETERS.
 - ALL DIMENSIONS ON REINFORCING ARE TO THE CENTER OF BARS.
 - CONCRETE SHALL BE THOROUGHLY WORKED AROUND REINFORCING. ANY EMBEDDED FIXTURES AND INTO ALL CORNERS OF FORMS.
 - IF REQUIRED, GROUT SHALL BE A MIXTURE OF 1 PART CEMENT TO 2 PARTS SAND WITH ENOUGH WATER TO PRODUCE A WORKABLE MIXTURE.
 - CONCRETE IS TO BE POURED ONLY WHEN THE ATMOSPHERIC TEMPERATURE IS A MINIMUM 40° F. (5° C.) AND RISING.
 - STRIP BACK ALL VEGETATION AND APPROXIMATELY 12" OF TOP SOIL. REMOVE ALL LOOSE CLODS AND STONES. BACKFILL AND THOROUGHLY COMPACT ALL CONDUIT TRENCHES AND HOLES BEFORE CONCRETE IS PLACED.
 - REINFORCING SHALL HAVE A MINIMUM OF 2½" CONCRETE COVER.
 - SLOPE PAD 1" FRONT TO BACK.
 - THE SQUARE OPENING IS FOR THE CUSTOMER'S SECONDARY CONDUITS.
 - CNP WILL NOT ALLOW OTHER FACILITIES TO PASS BENEATH ITS EQUIPMENT PADS. A ONE FOOT MINIMUM HORIZONTAL CLEARANCE SHALL BE MAINTAINED BETWEEN CNP PADS AND ALL OTHER FACILITIES.
 - THE SECONDARY OPENING IS TO BACKFILLED WITH SAND TO WITHIN 4" OF THE TOP OF THE PAD.

500-5000 KVA PMT
FOUNDATION, 12KV & 35KV

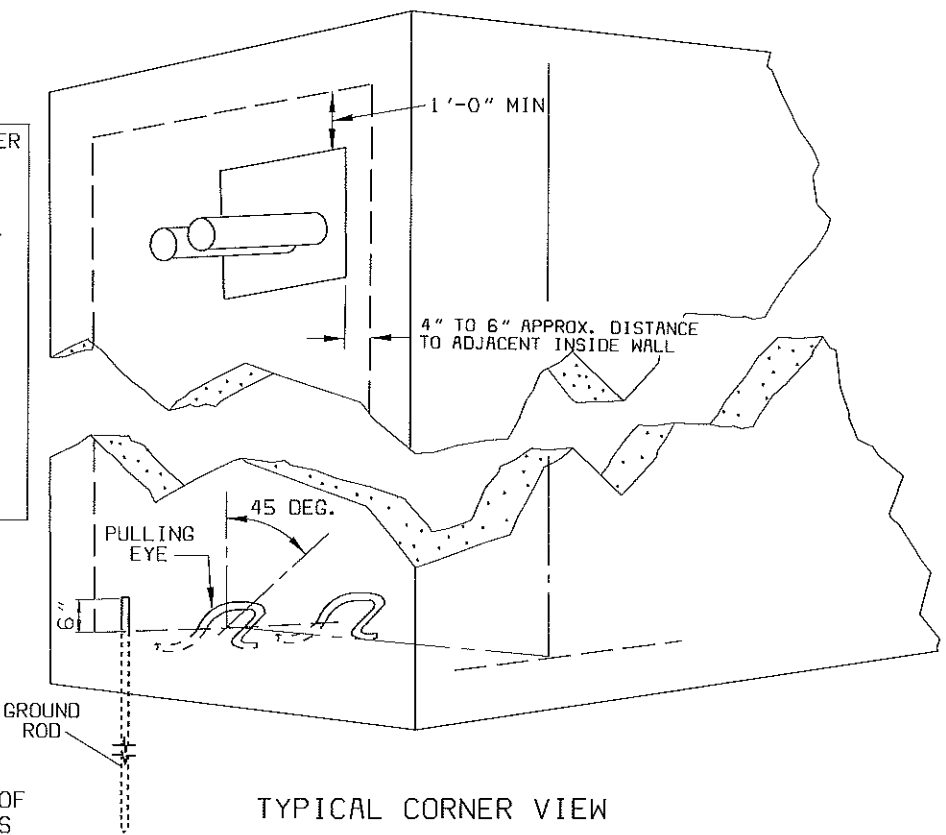
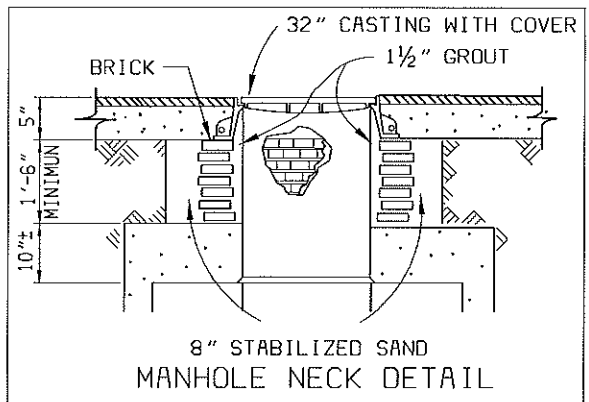
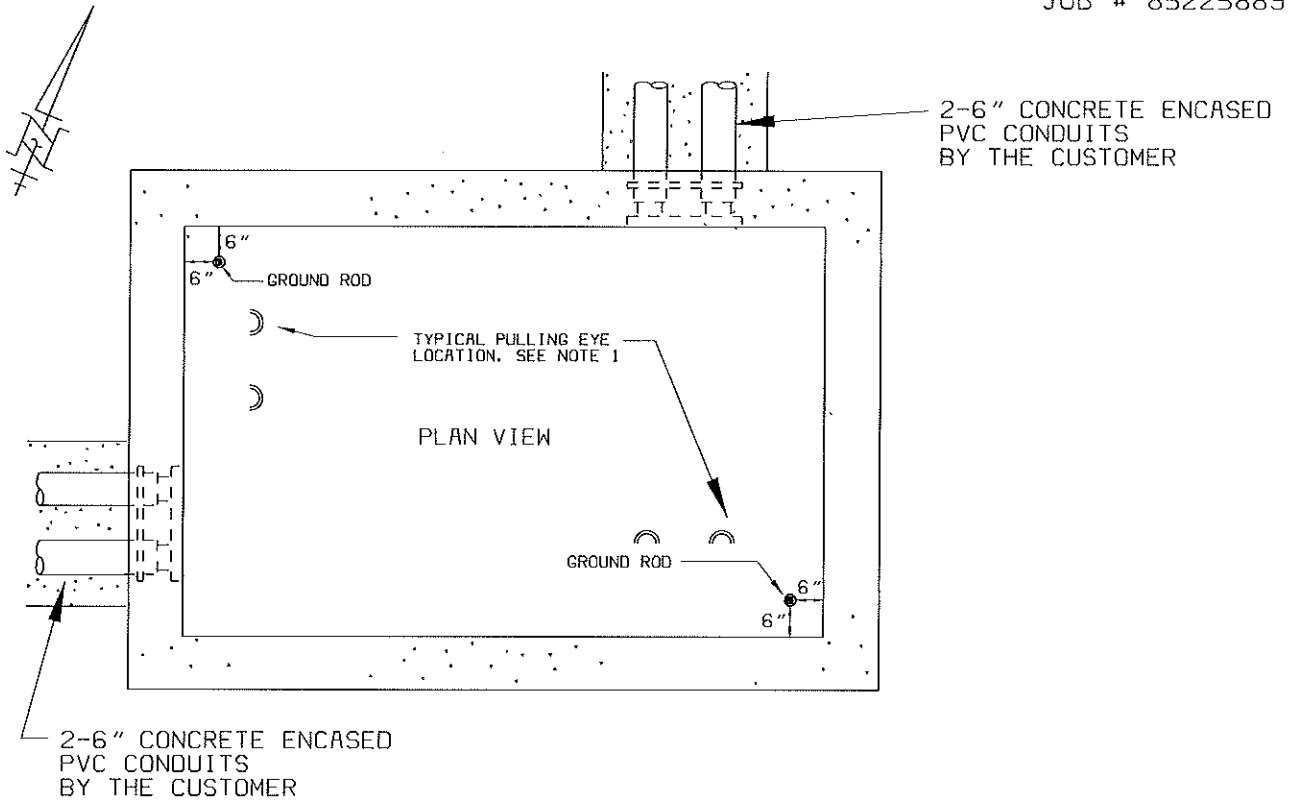

NOTES:

1. CNP RECOMMENDS THE INSTALLATION OF THE REQUIRED DUCTBELL TERMINATORS BY THE MANHOLE SUPPLIER ON ALL PRECAST MANHOLES.
2. MANHOLES ARE TO BE PLACED ON A MINIMUM OF SIX (6) INCH LEVELED BASE OF SAND OR CRUSHED ROCK TO INSURE UNIFORM DISTRIBUTION OF SOIL PRESSURE ON THE FLOOR.
3. CNP MUST INSPECT THIS REQUIREMENT PRIOR TO THE INSTALLATION OF THE MANHOLE INSIDE THE EXPOSED PIT.
4. THE USE OF PRECAST NECKS IS NOT APPROVED.

(PRECAST)
5' X 8' MANHOLE
12 & 35KV

MANHOLE NECK DETAIL

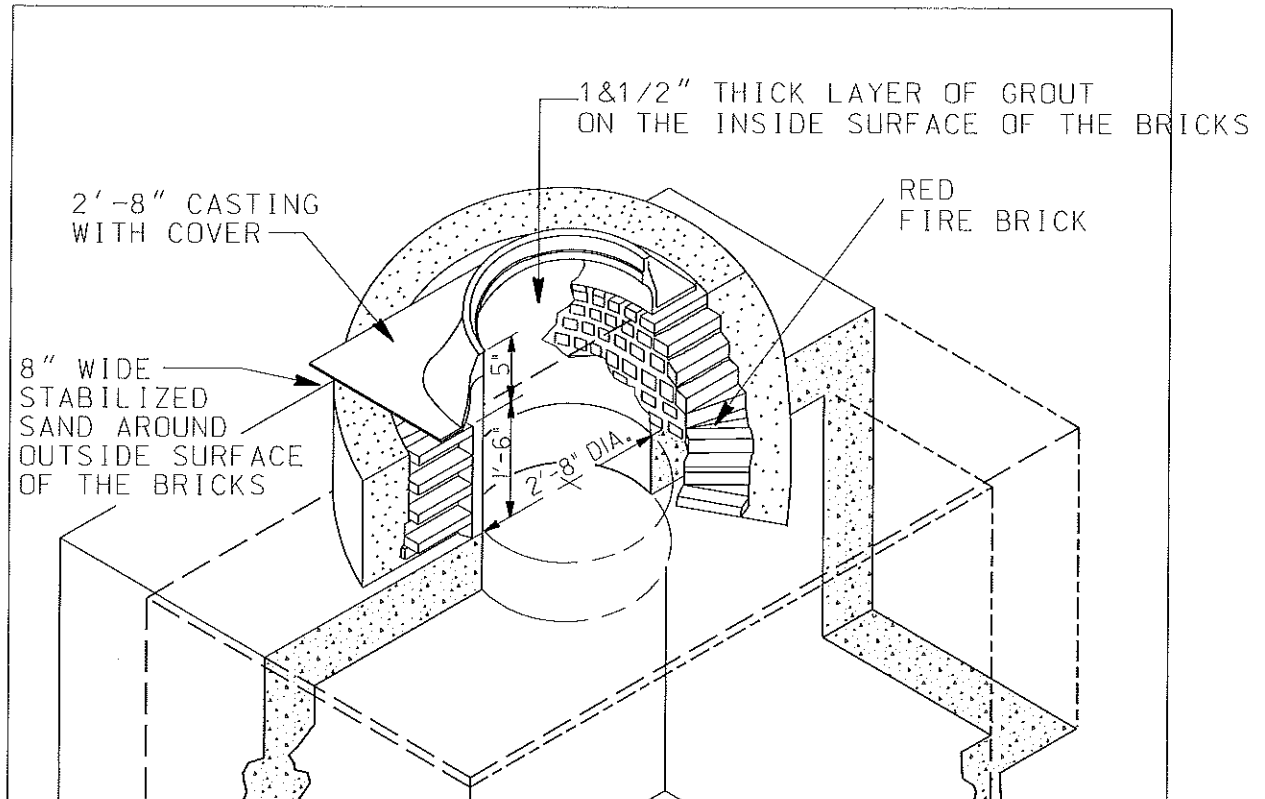

MANHOLE NECK NOTES:

1. MANHOLE NECK MUST BE INSPECTED BY CNP PRIOR TO BACKFILLING THE MANHOLE PIT.
2. MANHOLE CASTING MUST BE CENTERED ON MANHOLE OPENING.
3. MANHOLE CASTING WITH COVER IS TYPICALLY SUPPLIED BY CNP APPROVED PRECAST MANHOLE VENDOR.
4. MINIMUM 18" LAYERED RED FIRE BRICK CONSTRUCTION IS REQUIRED FROM MANHOLE CASTING TO TOP OF MANHOLE. 4' OR 6' CULVERT MAY BE USED IN ADDITION TO RED FIRE BRICK ASSEMBLY WHERE MANHOLE COVER IS 5' OR GREATER (REFERENCE EXTENDED HEIGHT NECK DETAIL).
5. RED FIRE BRICK ARE TO BE INSTALLED RADIALLY OUTWARD AS SHOWN ON MANHOLE NECK DETAIL.
6. RED FIRE BRICK ASSEMBLY MUST BE GROUTED USING STANDARD 3/8" MASONRY SPACING.
7. INNER PERIMETER OF MANHOLE NECK IS TO BE COATED WITH MINIMUM 1-1/2" THICKNESS OF GROUT, FASHIONED SUCH THAT THERE ARE NO LEDGES FROM THE CASTING TO THE TOP OF THE MANHOLE.
8. NO PRECAST RINGS ALLOWED.

(PRECAST)
MANHOLE NECK DETAIL
12 & 35KV

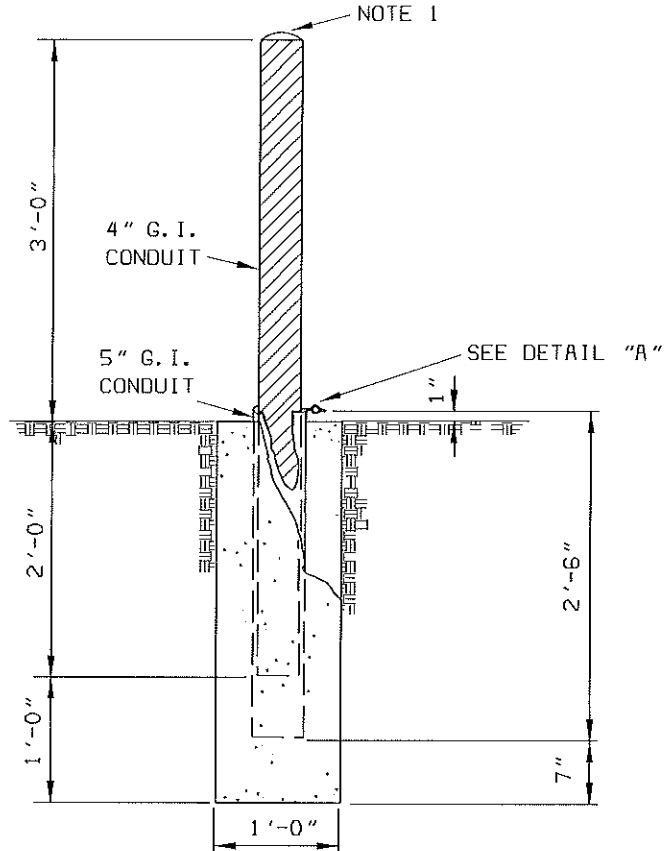
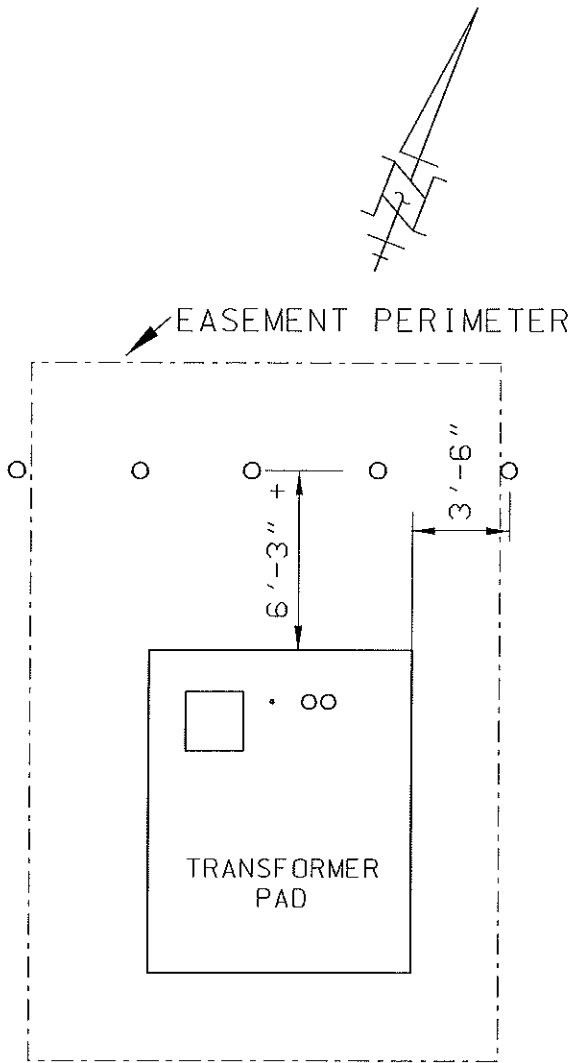

PROTECTIVE BARRIER
(REMOVABLE)

INSTALL FIVE (5) REMOVABLE
POST BARRIERS ON APPROXIMATELY
FOUR FOOT CENTERS

NOTES:

1. 4" G.I. CONDUIT TO BE FILLED WITH CONCRETE.
2. ANGLE TO BE WELDED TO G.I. CONDUIT. ALL EXPOSED METAL TO BE PAINTED WITH GALVANOX PAINT.
3. SEAL GAP BETWEEN CONDUITS WITH DUCT SEAL FOR WATER TIGHT FIT.
4. USE 5" PLUG TO PREVENT CONCRETE FROM COMING UP 5" G.I. CONDUIT.

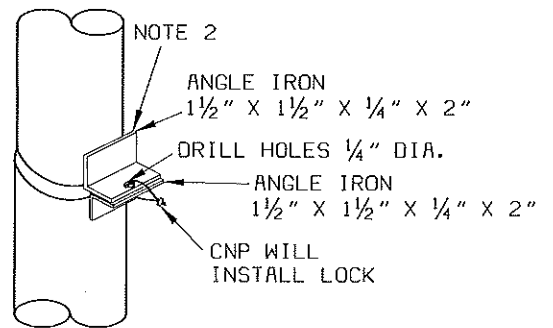

DETAIL "A"

PROTECTIVE BARRIER
(REMOVABLE)

ADDENDUM TO “TERMS AND CONDITIONS TO UNDERGROUND ELECTRIC SERVICE”

This Addendum is dated as of the Effective Date (as defined below) and is between CENTERPOINT HOUSTON ELECTRIC, LLC (the “Company”) and Lamar Consolidated Independent School District (“Customer”). The Company and Customer are referred to in this Addendum individually as a “Party” and collectively as the “Parties.”

Customer is the owner and operator of Thomas R. Culver, III Elementary School, 3131 Learning Tree Lane, Rosenberg, Texas 77471 (“Property”). (“Facilities”) shall mean any facilities, equipment, cable, or other material referred to in the Agreement installed and owned by the customer or his contractor at **3131 Learning Tree Lane, Rosenberg, Texas 77471** .

Contemporaneously with the execution of this Addendum, Customer and the Company are entering into THE TERMS AND CONDITIONS TO UNDERGROUND ELECTRIC SERVICE (the “Agreement”) under which underground electric service will be provided to the Facility. “Effective Date” means the date that the Agreement is signed, as indicated by the date next to the customer signature on the cover sheet of the Agreement.

Because of certain laws and regulations applicable to Customer, the Parties desire to set forth their understanding regarding those laws and regulations and the related allocation of certain risks and liabilities between them.

The Parties therefore agree as follows:

1. Applicability. This Addendum is being executed in connection with and will be deemed to be a part of the Agreement. No provision of the Agreement stating that the Agreement contains the entire understanding of the Parties with respect to its subject matter or other provision in the Agreement of the type typically referred to as a “merger clause” will apply to this Addendum. To the extent that the terms and provisions of this Addendum conflict with the terms and provisions of the Agreement, the terms and provisions of this Addendum control. Notwithstanding the execution of this Addendum, the Agreement remains in full force and effect, except as otherwise provided in this Addendum.

2. Customer as Governmental Entity. Customer represents and warrants that it is a governmental entity, and that as a governmental entity it is subject to constitutional and statutory limitations on its ability to be bound by certain terms and conditions of the Agreement, which may include terms and conditions relating to: liens on government property; disclaimers and limitations of warranties; disclaimers and limitations of liability for damages; waivers, disclaimers, and limitations on legal rights, remedies, requirements, commitment of future funding, and processes; limitations of time in which to bring legal action; control of litigation or dispute resolution; indemnities; and confidentiality of information, and to the extent that any provisions of the Agreement, including this Addendum, would violate any such restrictions, the Customer will not be bound by such provisions. Any terms or provisions of this Addendum that are less restrictive than those in the Agreement with respect to Customer’s obligations will be null and void and will have no force or effect if the representation and warranty that Customer is a governmental entity is not true or to the extent that the more restrictive term in the Agreement

would be enforceable against Customer under Applicable Laws (as defined below). Terms and conditions in the Agreement relating to limitations of the type described in this section will only be binding on Customer to the extent they are valid and enforceable under all applicable laws, including all state and federal laws, rules and regulations, the constitutions of the United States and the State of Texas and the laws of the United States and the State of Texas ("Applicable Laws").

3. Maintenance. Except to the extent expressly set forth in a written agreement between the Parties, the Company will not be required to maintain equipment, cable, or other material that is owned by Customer. Customer acknowledges that it is Customer's sole responsibility to follow the proper administrative or internal procedures to cause its Facilities and any related equipment to be properly maintained. Customer also acknowledges that Company reserves the right, in accordance with Company Tariff, to discontinue service if Customer has failed, or the Company has determined, in its sole discretion, that Customer has failed, to maintain the Property and facilities or any related equipment, cable or other material in a manner that causes or could cause a safety hazard to person or property.

4. Installation. Customer understands that all facilities, equipment, cable and other material referred to in the Agreement must comply with all specifications set forth in said Agreement and the Permanent Easement and/or Right to Pull before the Company installs any equipment or provides electrical service. During the installation of any equipment to be installed by the Company under the Agreement, the Company will use every effort to preserve Customer's landscaping, parking areas, or other facilities. However, any cost that has been quoted to Customer does not include any special replacements or repairs to these items. The Company shall not be responsible for any expenses associated with replacements or repairs to Customer's property, and Customer hereby waives any claims for such expenses that it has or may have against the Company.

5. INDEMNIFICATION. This indemnity is pursuant to Company's Tariff located on our website at www.centerpointenergy.com. CUSTOMER ASSUMES THE RISK OF AND SHALL INDEMNIFY COMPANY AGAINST DAMAGES FOR INJURIES OR DEATH TO PERSONS OR LOSS TO CUSTOMER'S PROPERTY, OR TO THE PROPERTY OF COMPANY, WHEN OCCASIONED BY ACTIVITIES OF CUSTOMER OR THIRD PARTIES ON CUSTOMER'S PREMISES, RESULTING FROM THE INSTALLATION, EXISTENCE, REPLACEMENT, OR REPAIR OF COMPANY'S UNDERGROUND FACILITIES, AND AS FURTHER PROVIDED IN THE TERMS OF "LIMITS ON LIABILITY," SECTION 5.2 OF COMPANY'S TARIFF. NOTWITHSTANDING ANY OF THE ABOVE, THE PROVISIONS REQUIRING A CUSTOMER TO INDEMNIFY, FULLY PROTECT, OR SAVE COMPANY HARMLESS APPLY TO A GOVERNMENTAL ENTITY AS THIS TERM IS DEFINED IN CHAPTER 2251 OF THE TEXAS GOVERNMENT CODE, TO THE EXTENT OTHERWISE CONSISTENT WITH LAW; PROVIDED, HOWEVER, THAT ANY GOVERNMENTAL ENTITY THAT IS RECEIVING SERVICES UNDER THE AGREEMENT MUST TAKE NECESSARY STEPS TO ENSURE THAT THE INDEMNIFICATION REQUIREMENTS OF THIS SECTION DO NOT CREATE A "DEBT" IN VIOLATION OF ARTICLE XI, SECTION 7 OF THE TEXAS CONSTITUTION. SUCH STEPS MAY INCLUDE, BUT ARE NOT NECESSARILY LIMITED TO, A THIRD-PARTY INDEMNIFICATION IN WHICH THE

CONTRACTOR PERFORMING THE WORK FOR THE GOVERNMENTAL ENTITY INDEMNIFIES THE COMPANY OR THE ESTABLISHMENT OF A SINKING FUND. *SEE BROWN V. JEFFERSON COUNTY, 406 S.W.2D 185 (TEX. 1966).*

6. Further Assurances. If at any time after the date of this Addendum any further action is necessary or appropriate to carry out the purposes of this Addendum, Customer shall use all commercially reasonable efforts to take, or cause to be taken, that action.

7. Assignment. Customer shall not assign any part of its rights or delegate any performance under this Addendum, voluntarily or involuntarily, whether by merger, consolidation, dissolution, operation of law, or any other manner, without the Company's prior written consent. Any purported assignment of rights or delegation of performance in violation of this Section 7 is void and of no effect.

8. Modification; Waiver. No amendment of this Addendum will be effective unless it is in writing and signed by the Parties. No waiver of satisfaction of a condition or nonperformance of an obligation under this Addendum will be effective unless it is in writing and signed by the Party granting the waiver, and no such waiver will constitute a waiver of satisfaction of any other condition or nonperformance of any other obligation. To be valid, any document signed by a Party in accordance with this Section 8 must be signed by an officer or other representative of that Party authorized to do so.

In addition, nothing in this Addendum or the Agreement shall be construed as a waiver or relinquishment by the Company of any right that it has or may have hereafter to discontinue service for or on account of default in the performance of Customer's obligations under this Addendum or the Agreement, including payment of any bill owing or to become owing thereafter, or for any other reason or cause stated in the Company's Tariff.

[The remainder of this page has been intentionally left blank.]

The Parties are signing this Addendum as of the Effective Date.

COMPANY:

CENTERPOINT ENERGY HOUSTON
ELECTRIC, LLC

By:  _____

Name: Adewemimo A. Oyekenu, P. E.

Title: Supervising Engineer

CUSTOMER:

**LAMAR CONSOLIDATED INDEPENDENT
SCHOOL DISTRICT**

By signing this Addendum, the person purporting to sign this Addendum on behalf of Customer is representing and warranting to the Company that the person has the legal authority to bind Customer and has been duly authorized by Customer to sign and deliver this Addendum to the Company.

By: _____

Name: James Steenbergen

Title: Board President

SPECIFICATION FOR

Customer Emergency Generation and Secondary Load Transfer

**CENTERPOINT ENERGY
ELECTRIC DISTRIBUTION ENGINEERING
P.O. BOX 1700 HOUSTON, TEXAS 77251**

REFERENCE DRAWINGS:

REFERENCE SPECIFICATIONS:

National Electrical Code
CNP Specification 007-231-76
PUCT Substantive Rule 25.212
IEEE Standard 519-1992 (or latest revision)



						WRITTEN		R.W. Comfort
						CHECKED		
						APPROVED	11-16-88	L.G. Pond
1	7-11-07	Complete Revision	SLJ	WSC	RKM/ LSN		SHEET 1 of 14 SHEETS	
NO.	DATE	ITEMS REVISED	BY	CH	APP		007	231

CONTENTS

<u>Article No.</u>	<u>Title</u>	<u>Page No.</u>
1.0	SCOPE	3
2.0	POLICY ON EMERGENCY GENERATION	3
3.0	POLICY ON SECONDARY LOAD TRANSFER	4
4.0	APPROVAL	5
	FIGURES	7-14

REVISION NO. 1

SPECIFICATION NO.

007

231

82

SHEET 2 of 14 SHEETS

1.0 SCOPE

- 1.1 Hereafter, CenterPoint Energy will be designated as “CNP” and the Contractor, Customer, or Facility Owner will be designated as “Customer”.
- 1.2 This specification covers the minimum requirements for the operation of customer owned emergency generation, and the operating procedures for secondary load transfer on the customer’s distribution system. The requirements in this specification are in addition to those stated in the National Electrical Code (NEC) and all other applicable governing authorities.

2.0 POLICY ON EMERGENCY GENERATION

- 2.1 Customer owned emergency generation must be connected to the customer’s load through either an open-transition type transfer switch or a key interlocked two breaker/switch arrangement.
- 2.2 The open-transition type transfer switch or interlocked two breaker/switch arrangement must be designed to prevent the electrical and/or physical connection between the CNP distribution system and the customer generator bus. See Figures 1, 2, 3 and 4 on sheets 7, 8, 9 and 10 for the acceptable connections of the emergency generator to the customer’s bus.
- 2.3 Exceptions to the above requirements (i.e. operating an emergency generator in parallel with the CNP system through the use of a closed transition transfer switch) will be granted under the following conditions.
 - 2.3.1 Customers utilizing a closed transition transfer switch with their emergency generator must install protective devices in accordance with Public Utility Commission of Texas (PUCT) Substantive Rule 25.212 and specified in the CNP Specification for Customer Generation on the Distribution System (007-231-76). These protective devices must be installed at the interconnection point between CNP and the customer.
 - 2.3.2 The level of voltage and current distortion produced by the customer’s generator must be in accordance with IEEE Standard 519-1992 (or latest revision).
- 2.4 Customers served from an existing CNP secondary network system will not be allowed to operate their emergency generators in parallel with CNP.
- 2.5 Generator(s) and its exhaust must be located where it will not interfere with CNP personnel or equipment. The location of the generator must be approved by CNP prior to installation.
- 2.6 Customers may not install or use any transfer switch on the high side (CNP side) of the meter or any transfer switch between the meter and the meter socket jaws. Customer owned standby generators must be located on the load side (customer side) of the meter, behind the main breaker (switch).

REVISION NO. 1	SPECIFICATION NO.		007	231	82	SHEET 3 of 14 SHEETS
----------------	-------------------	--	-----	-----	----	----------------------

3.0 POLICY ON SECONDARY LOAD TRANSFER

- 3.1 The following policy applies to customers whose split load is served from two feeds on the CNP distribution system. These feeds may or may not originate from electrically separate circuits.
- 3.2 Customers should design their distribution system in such a manner that the distribution buses served from each feed shall always be electrically isolated from each other. See Figure 5 on sheet 11 for illustration.
- 3.3 (A) Customers served from two CNP feeds where CNP provides manual transfer service may be allowed to transfer pre-approved loads (in accordance with Section 3.6 below) from one CNP feed to the other in the event of a circuit outage. (B) Customers served from two or three CNP feeds where CNP provides automatic transfer service may be allowed to transfer pre-approved loads (in accordance with Section 3.6 below) in the event of a secondary outage on the CNP service to the affected customer.
- 3.4 The secondary load transfer for either Sections 3.3(A) or 3.3(B) shall be done manually. Automatic load transfer by the customer will not be permitted without CNP Engineering approval. Prior to the transfer of load, the customer must manually shed pre-approved loads on the receiving feed. The magnitude of load to be shed must be equal to or greater than the amount of load to be transferred, so that the normal load level of the receiving feed is never exceeded. These limits will be provided to the customer as a condition for electric service. This condition applies to Section 3.3(A). Customers served from two or three circuit automatic transfer service are typically provided service from either a normal circuit with a second as the back up or from a split service arrangement. Upon the loss of a circuit CNP equipment is relayed to automatically transfer to the non affected circuit(s). This CNP automatic transfer typically occurs within a few seconds, utilizing open transition rollover. Normalization occurs within an eighty second closed transition rollback. In a CNP split load arrangement a fault between the customer's service and the low side of CNP transformers may occur. Under this condition automatic transfer does not occur, because the fault could either be due to CNP or the customer's equipment. If the fault occurs on the customer's equipment, the customer will not be allowed to transfer loads. If the fault occurred on CNP equipment, CNP may isolate the service and the customer may manually transfer pre-approved loads. The magnitude of loads to be transferred shall not overload CNP transformers. This condition applies to Section 3.3(B).
- 3.5 Where system capacity is available, customers served from a CNP underground network system may be allowed to manually transfer (in accordance with Section 3.6 below) pre-approved loads. Typical network services consist of multiple CNP transformers connected in parallel. In network and spot network services that do not have a CNP tie breaker the customer can transfer loads as long as the rating of the customer's secondary bus or cables are not exceeded. In services containing a CNP tie breaker, the customer may manually transfer loads from one of their services to another provided the rating of the tie breaker is not exceeded and/or a fault does not exist on the secondary side of either CNP equipment or the customer's service(s).

- 3.6 All load transfers shall be done utilizing open-transition transfer switches/breakers. See Figure 6 on sheet 12 for illustration.
- 3.7 If the customer utilizes a three breaker/switch arrangement to transfer critical load between their two buses, the breaker/switch schemes must use both keyed and hard wire auxiliary contacts to operate feeder and tie breakers/switches. Electromechanical, electronic and keyed control of these devices will require that the tie breaker/switch cannot close unless one of the feeder breakers/switches is opened. See Figure 7 on sheet 13.
- 3.8 Secondary Load Transfer Capability will only be offered in conjunction with separate contractual arrangements between CNP and the customer, and where provisions to assure adequate circuit capacity and compliance with this specification have been made.

4.0 APPROVAL

- 4.1 The following items must be submitted to the CNP Manager of Distribution Engineering or designated representative for approval.
- 4.2 Emergency Generation
 - 4.2.1 The customer must submit 2 copies of their detailed electrical system (drawings and schematics) showing their emergency generator, transformers, circuit breakers, transfer switches and key interlocked scheme. CNP Engineering personnel will approve only those portions of the drawing which apply to the operation and connection of the generator to the customer's load. A copy of the transfer switch instruction book and descriptive literature must also be submitted for approval. In lieu of hard copies, compatible electronic file formats are acceptable for submission.
- 4.3 Secondary Load Transfer
 - 4.3.1 The customer must submit a load transfer schedule detailing the exact amount of load to be shed on the receiving feed prior to load transfer and the exact amount of load to be transferred. The format of this load transfer schedule shall be in accordance with Figure 8 on sheet 14.
 - 4.3.2 The customer must submit 2 copies of their detailed electrical system (drawings and schematics) showing all transfer switches. A copy of the transfer switch instruction book and descriptive literature must also be submitted for approval. In lieu of hard copies, compatible electronic file formats are acceptable for submission.

4.3.3 Customers utilizing a three breaker/switch arrangement for load transfer must provide a detailed control wiring diagram of the breaker/switch operation. The wiring diagram must show the electromechanical and key interlocks used to prevent the closing of the tie breaker/switch before one of the feeder breakers/switches is opened. See Figure 7 on sheet 13 for illustration.

4.3.4 After receipt of the above, CNP Engineering personnel will review the documents for approval. The amount of load the customer proposes to transfer from one CNP feed to another will be approved by CNP personnel. In all cases CNP personnel will verify that existing CNP facilities (Transformer Capacity, Secondary Bus Work, etc.) can accommodate the Load Transfer. If approval is granted, an Operation Agreement will be prepared detailing the operating procedures to be followed by the customer while transferring load between CNP feeds. The Operation Agreement will also specify the maximum load that the customer will be allowed to transfer. Final written approval will not given until the customer has reviewed and signed this Agreement, and one signed copy has been received by CNP personnel.

REVISION NO. 1

SPECIFICATION NO.

007

231

82

SHEET 6 of 14 SHEETS

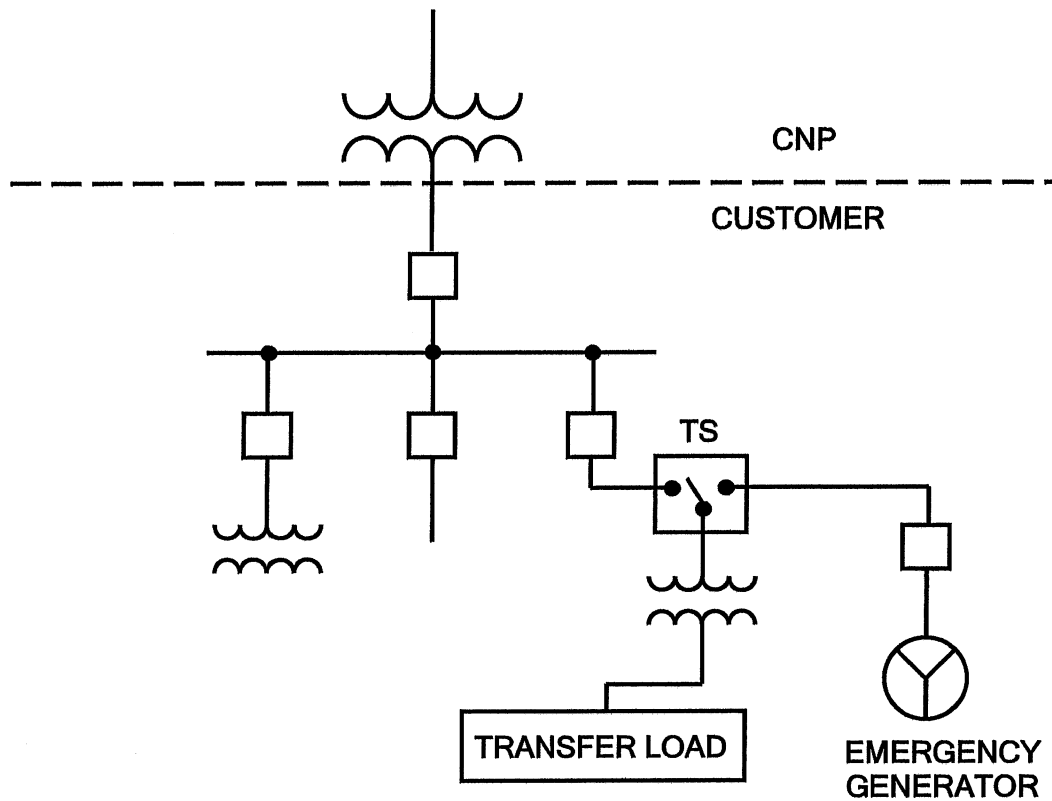

ACCEPTABLE CONNECTION OF EMERGENCY GENERATOR TO CUSTOMER DISTRIBUTION BUS.

TS - TRANSFER SWITCH

FIGURE 1

REVISION NO. 1	SPECIFICATION NO.		007	231	82	SHEET 7 of 14 SHEETS
----------------	-------------------	--	-----	-----	----	----------------------

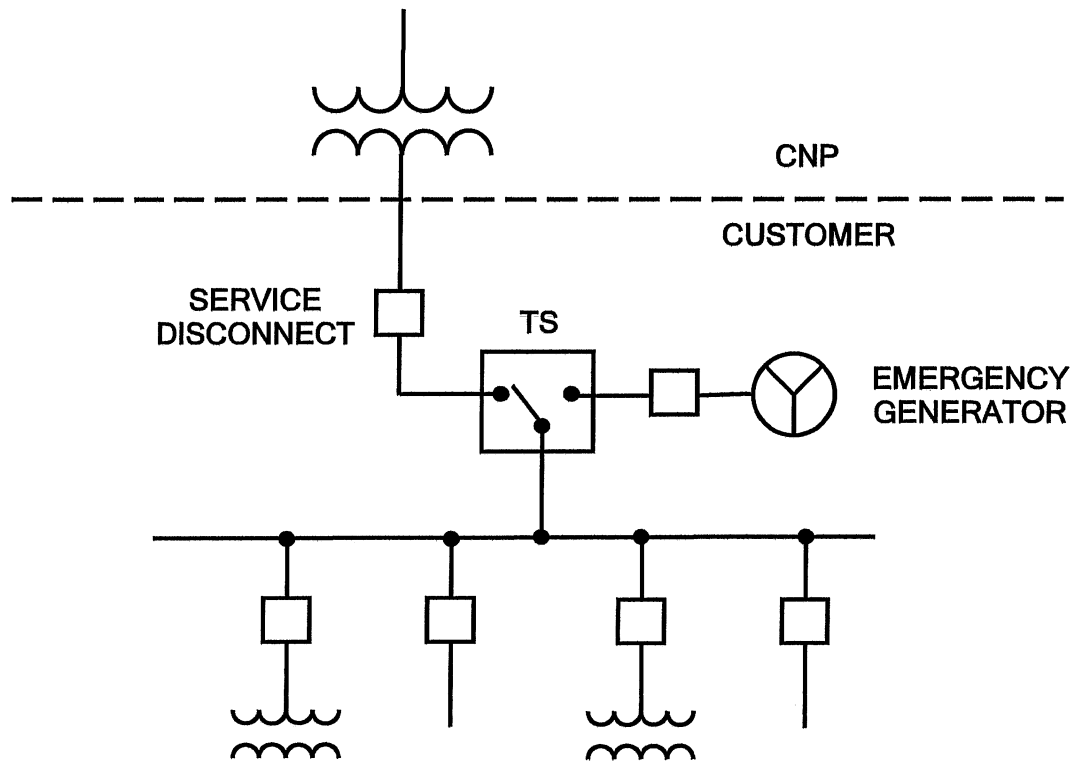

ACCEPTABLE CONNECTION OF EMERGENCY GENERATOR TO CUSTOMER DISTRIBUTION BUS.

TS - TRANSFER SWITCH

FIGURE 2

REVISION NO. 1	SPECIFICATION NO.	007	231	82	SHEET 8 of 14 SHEETS
----------------	-------------------	-----	-----	----	----------------------

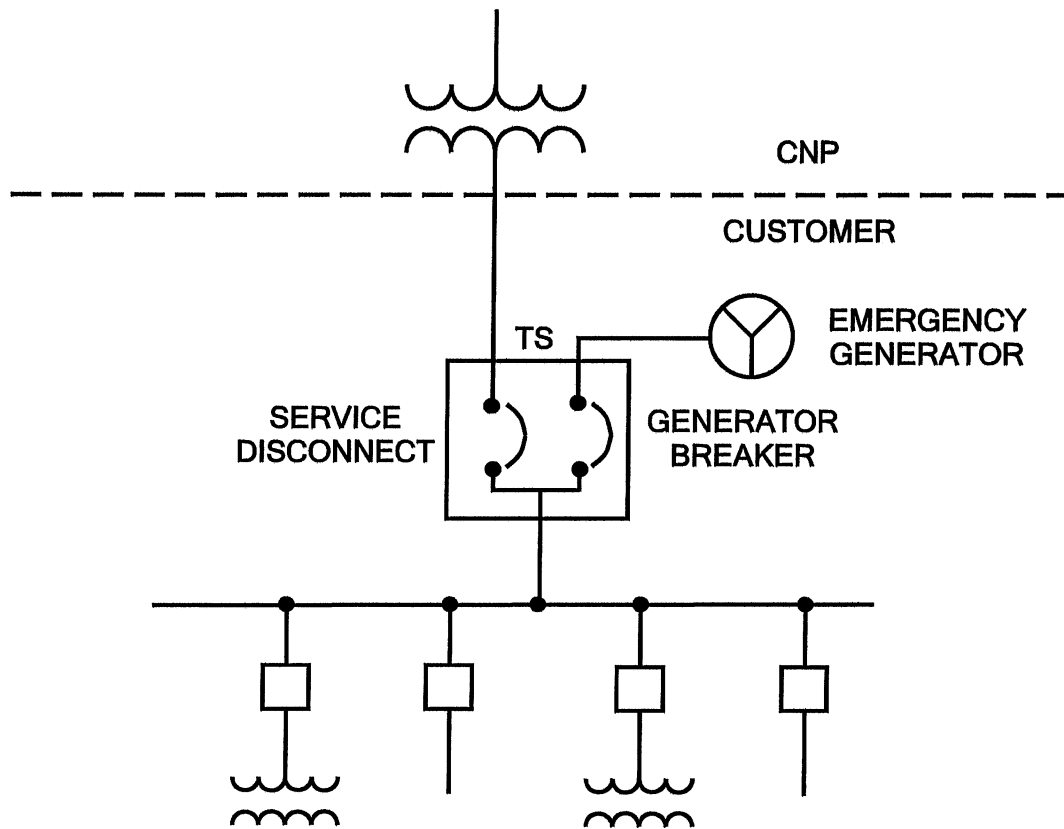

ACCEPTABLE CONNECTION OF EMERGENCY GENERATOR TO CUSTOMER DISTRIBUTION BUS UTILIZING TWO BREAKER TRANSFER SWITCH WITH ELECTRICAL AND MECHANICAL INTERLOCKS

TS - TRANSFER SWITCH

FIGURE 3

REVISION NO. 1	SPECIFICATION NO.	007	231	82	SHEET 9 of 14 SHEETS
----------------	-------------------	-----	-----	----	----------------------

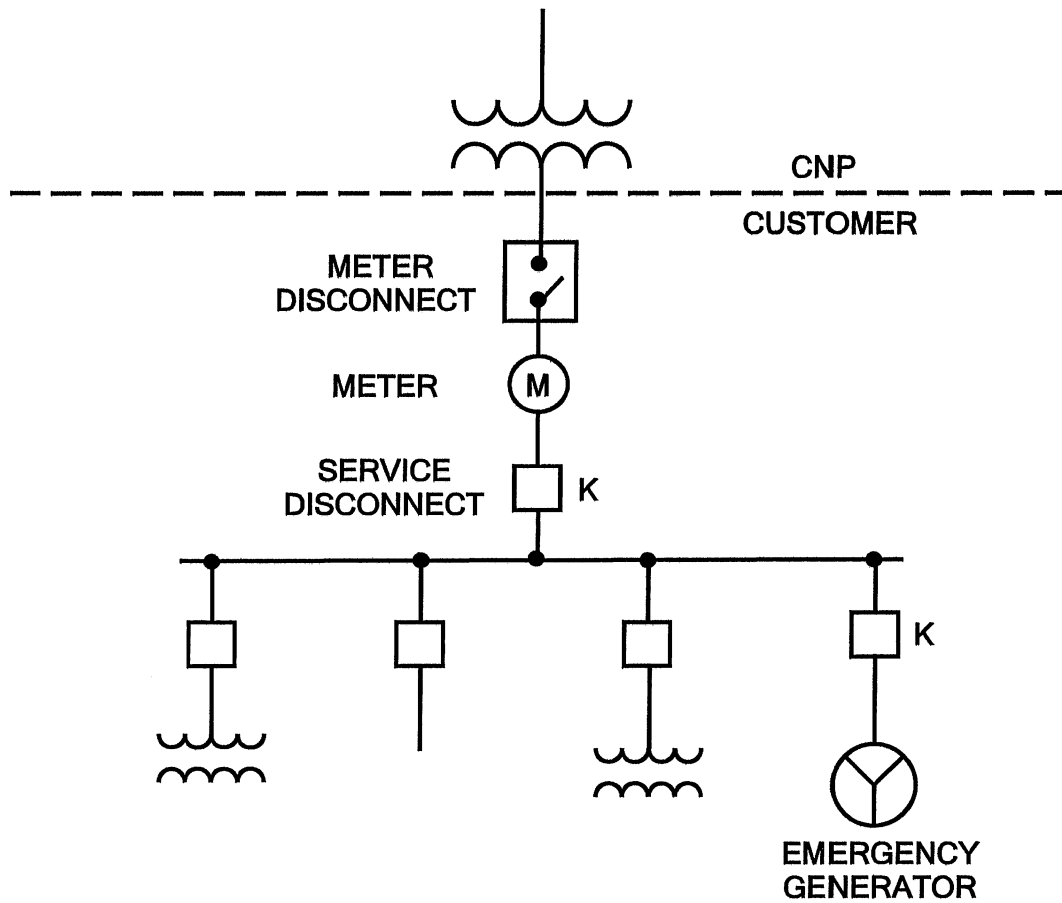

ACCEPTABLE CONNECTION OF EMERGENCY GENERATOR TO CUSTOMER DISTRIBUTION BUS UTILIZING KEY INTERLOCKED SERVICE DISCONNECT/BREAKER AND GENERATOR BREAKER/ ISOLATION SWITCH.

METER DISCONNECT IS ONLY REQUIRED FOR 480 V SELF-CONTAINED METER INSTALLATIONS AND IT CANNOT BE UTILIZED IN THE KEY INTERLOCK SCHEME.

K - KEY INTERLOCKS

FIGURE 4

REVISION NO. 1	SPECIFICATION NO.	007	231	82	SHEET 10 of 14 SHEETS
----------------	-------------------	-----	-----	----	-----------------------

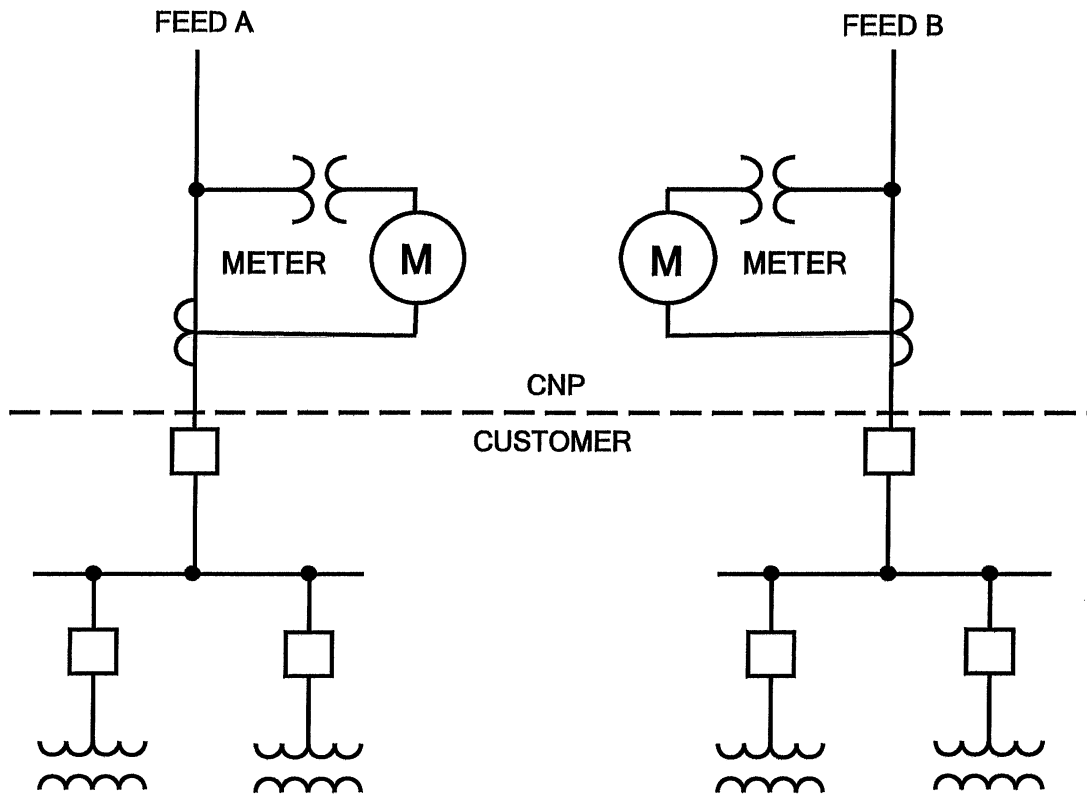

ACCEPTABLE ARRANGEMENT FOR CUSTOMERS
FED FROM TWO SEPERATE FEEDS.

FIGURE 5

REVISION NO. 1

SPECIFICATION NO.

007

231

82

SHEET 11 of 14 SHEETS

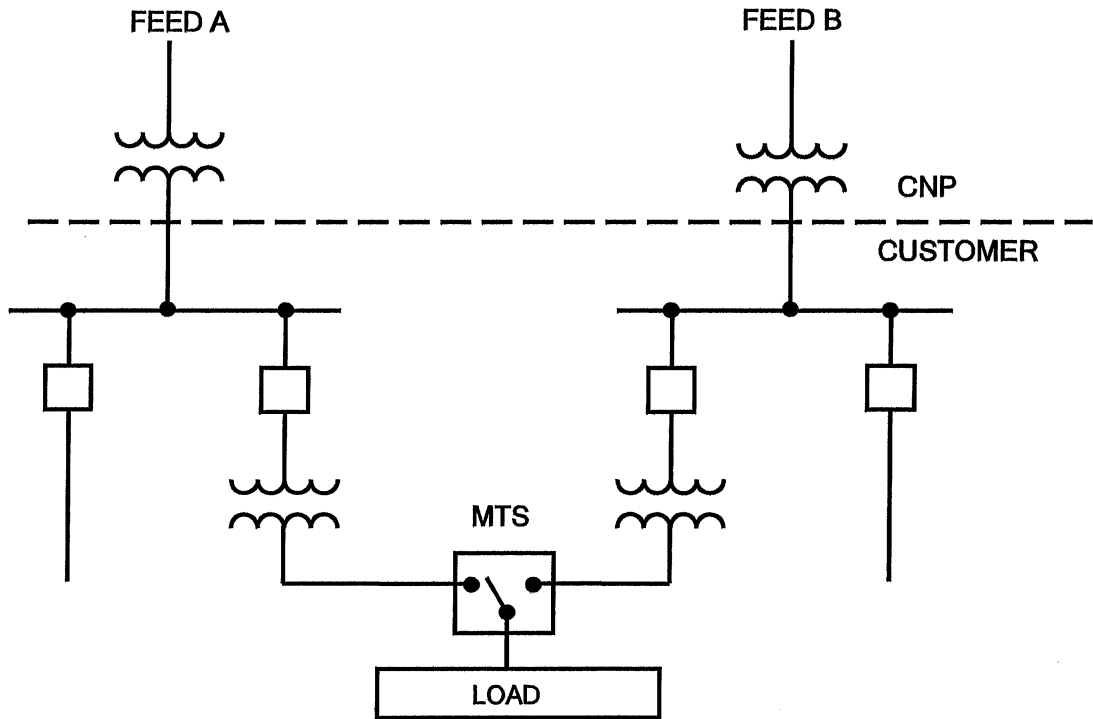

ACCEPTABLE SECONDARY LOAD TRANSFER SCHEME.

MTS - MANUAL TRANSFER SWITCH

FIGURE 6

REVISION NO. 1

SPECIFICATION NO.

007

231

82

SHEET 12 of 14 SHEETS

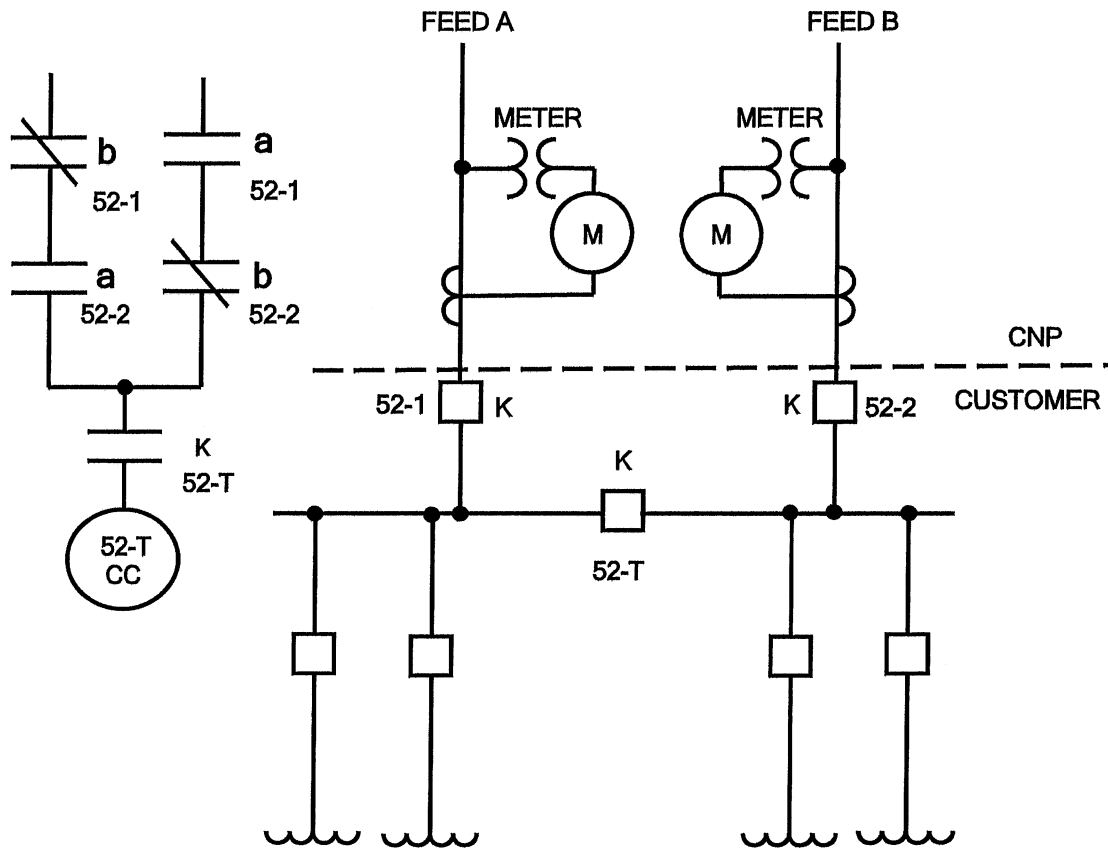

ACCEPTABLE CONTROL SCHEME FOR KEY INTERLOCKED SWITCHES / BREAKERS UTILIZED FOR SECONDARY LOAD TRANSFER.

52-T
CC - TIE BREAKER / SWITCH CLOSE COIL

52-1, 52-2 - CUSTOMER MAIN FEEDER BREAKERS (K - KEY INTERLOCKS)

52-T - CUSTOMER TIE BREAKER / SWITCH (K - KEY INTERLOCKS)

FIGURE 7

REVISION NO. 1

SPECIFICATION NO.

007

231

82

SHEET 13 of 14 SHEETS

EMERGENCY LOAD TRANSFER SCHEDULE

CUSTOMER'S CIRCUIT NO.	CIRCUIT (LOAD) DESCRIPTION	<u>CNP FEED "A"</u> NORM. EMER.		<u>CNP FEED "B"</u> NORM. EMER.	
1)	PUMP	1100	900	1000	1100
2)	AEROBIC DIGESTERS	1250	1500	1320	1200
3)	AIR COMPRESSORS	1620	1500	1400	1300
TOTAL CONNECTED LOAD (KVA)		3970	3900	3720	3600

NOTE: NORMAL LOAD LEVELS APPLY WHEN BOTH CNP FEEDS ARE ENERGIZED.

EMERGENCY LOAD LEVELS APPLY WHEN ONE OF THE CNP FEEDS IS DE-ENERGIZED AND THE CRITICAL LOAD IS TRANSFERRED TO THE REMAINING ENERGIZED FEED.

THE ABOVE TABLE IS FOR ILLUSTRATION ONLY.

FIGURE 8

**SHORT FORM BLANKET EASEMENT
3-PHASE OVERHEAD AND UNDERGROUND**

NOTICE OF CONFIDENTIALITY RIGHTS: IF YOU ARE A NATURAL PERSON, YOU MAY REMOVE OR STRIKE ANY OR ALL OF THE FOLLOWING INFORMATION FROM ANY INSTRUMENT THAT TRANSFERS AN INTEREST IN REAL PROPERTY BEFORE IT IS FILED FOR RECORD IN THE PUBLIC RECORDS: YOUR SOCIAL SECURITY NUMBER OR YOUR DRIVER'S LICENSE NUMBER.

STATE OF TEXAS }
 } KNOW ALL PERSONS BY THESE PRESENTS:
COUNTY OF FORT BEND}

 THAT, Lamar Consolidated Independent School District, hereinafter referred to as "Grantor", whether one or more, for and in consideration of the sum of ONE DOLLAR (\$1.00) CASH to Grantor paid by CenterPoint Energy Houston Electric, LLC, its successors and assigns, hereinafter referred to as "Grantee", whose principal address is P. O. Box 1700, Houston, Texas 77251-1700, has **GRANTED, SOLD AND CONVEYED** and by these presents, does **GRANT, SELL AND CONVEY** unto said Grantee, all or in part, a perpetual **blanket** easement, hereinafter referred to as the "Easement", for electric distribution and related communication facilities consisting of a variable number of wires and cables and all necessary and desirable equipment and appurtenances, including, but not limited to, towers or poles made of wood, metal or other materials, props and guys, hereinafter referred to as "Facilities", lying on, over, under, and across the following described lands owned by Grantor, ("Grantor's Property"), to wit:

 Restricted Reserve "A" of Lamar CISD Thomas R Culver III Elementary School, a subdivision out of the Angus J. James Survey, Abstract 37, Fort Bend County, Texas, according to the map or plat thereof recorded in Plat No. 20180123 of the Plat Records of said county and state.

The Easement Area herein granted is a blanket easement and shall apply only insofar as the boundaries of Grantor's Property will permit. Grantee further reserves the right to extend services and drops within Grantor's Property and to adjacent land owners from said Facilities.

Grantor or its successors or assigns shall observe and exercise all notification laws as per the Underground Facility Damage Prevention and Safety Act, also known as "ONE CALL" & "CALL BEFORE YOU DIG" when working in or near the Easement Area.

To the extent that such laws and codes apply to Grantor, its successors and assigns, Grantor, its successors and assigns shall observe all safety codes and laws which apply to working along, within and or near the Easement Area and Facilities during construction activities and safe clearance from such Facilities, including the Occupational Safety and Health Administration ("O.S.H.A."), Chapter 752 of the Texas Health and Safety Code, the National Electric Code, and the National Electrical Safety Code.

Grantor herein reserves the right to grant easements in favor of third parties across the herein described Easement Area in a near perpendicular fashion to Grantee's Facilities, the approximate locations of which are shown on Exhibit "A", attached hereto and made a part hereof, provided (i) no other utilities are permitted to cross within a vertical distance of twenty-four (24) inches of Grantee's below ground Facilities, (ii) no other facilities or structures shall be permitted longitudinally within a distance of five (5) feet of the centerline of any of Grantee's below ground and above ground Facilities, (iii) no other utilities or structures shall be permitted longitudinally within a distance of fifteen (15) feet of the centerline of any of Grantee's overhead Facilities, beginning at a plane sixteen (16) feet above the ground and extending upward, hereinafter collectively referred to as "Grantee's Exclusive Easement Area", and, (iv) doing so does not, in the sole opinion of Grantee,

endanger or interfere with the efficient, safe and proper operation and maintenance of Grantee's Facilities.

Grantor herein covenants and agrees that, in the event that any third party facilities or obstructions are located within Grantee's Exclusive Easement Area, Grantor will take immediate action to remove and/or relocate said facilities and/or obstructions to a location outside of Grantee's Exclusive Easement Area at Grantor's sole cost and expense.

If Grantor, its successors or assigns should, at any future date, request that the Easement Area herein granted be further defined, Grantee agrees, at Grantor's expense, to prepare a new, defined easement described by a sealed survey sketch. Defined easements shall be unobstructed and may be further described by, but not limited to, the following descriptions:

- 1.) A ten (10) foot wide easement (for above and below ground facilities);
- 2.) A ten (10) foot wide easement together with ten (10) foot aerial easements adjoining both sides of said ten (10) foot wide easement (for above ground and overhead facilities that are not along a perimeter);
- 3.) A ten (10) foot wide easement together with an adjoining eleven (11) foot, six (6) inch wide aerial easement (for above ground and overhead perimeter facilities);
- 4.) A fourteen (14) foot wide easement together with an adjoining seven (7) foot, six (6) inch wide aerial easement (for above ground and overhead perimeter facilities);
- 5.) An easement sixteen (16) feet wide and twenty-four (24) feet long (for Grantee's pad-mounted transformer station purposes).

Grantee further agrees to release this Easement upon execution and delivery of the new defined easement by Grantor.

In the event that Grantor, its successors and assigns, desires that Grantee's Facilities be relocated, then Grantee agrees to relocate said Facilities provided that Grantor furnishes a suitable and feasible site or location for such relocation and, provided that Grantor, its successors and assigns, shall, if requested by Grantee, furnish to Grantee a

suitable and acceptable easement covering the new location. Any and all costs associated with relocating said Facilities will be at Grantor's sole expense.

Grantee shall also have reasonable rights of ingress and egress to and from said Easement Area, together with reasonable working space, for the purposes of erecting, installing, operating, maintaining, replacing, inspecting, and removing said Facilities, together with the additional right to remove from said Easement Area, all bushes, trees and parts thereof, or other structures which, in the opinion of Grantee, endanger or may interfere with the efficiency, safe and proper operation, and maintenance of said Facilities.

TO HAVE AND TO HOLD the above described Easement, together with all and singular the rights and appurtenances thereto in anywise belonging, unto Grantee forever, and Grantor does hereby bind itself and its successors, heirs, assigns, and legal representatives, to fully warrant and forever defend all and singular the above described Easement and rights unto said Grantee, against every person whomsoever lawfully claiming or to claim the same or any part thereof, by, through or under Grantor, but not otherwise. In the event of a deficiency in title or actions taken by others which results in the relocation of Grantee's Facilities, the Grantor herein, its successors and assigns, will be responsible for all costs associated with the relocation and/or removal of Grantee's Facilities.

The terms, conditions and provisions contained herein constitute the complete and final agreement between Grantor and Grantee, (collectively the "Parties") with respect to the subject matter hereof and supersedes all prior agreements, representations and understandings of the Parties and, by Grantor's signature affixed hereto and Grantee's use of the Easement, the Parties evidence their agreement thereof. No oral or written agreements made or discussed prior to, or subsequent to, the execution of this Easement shall supersede those contained herein. Any and all revisions, amendments and/or exceptions to the terms, conditions and provisions contained in this Easement shall be in written, recordable form and executed by both parties, or their respective successors or assigns in order to be deemed valid.

EXECUTED this _____ day of _____, 20____.

Lamar Consolidated Independent School District

BY: _____
Signature

James Steenbergen
Name typed or printed

Board President
Title

STATE OF TEXAS }

COUNTY OF _____}

BEFORE ME, the undersigned authority, a Notary Public in and for the State of Texas, on this day personally appeared James Steenbergen - Board President, _____ of Lamar Consolidated Independent School District, known to me to be the person whose name is subscribed to the foregoing instrument and acknowledged to me that (__)he executed the same for the purposes and consideration therein expressed, in the capacity therein stated, and as the act and deed of said district.

Given under my hand and seal of office this _____ day of _____, 20____.

Notary's Signature

Name typed or printed

Commission Expires

**ATTACHMENT
AFFIDAVIT**

STATE OF TEXAS }

COUNTY OF FORT BEND}

BEFORE me the undersigned authority on this day personally appeared

_____ James Steenbergen _____ the _____ Board President _____

of Lamar Consolidated Independent School District, hereinafter referred to as Affiant, who being duly sworn, deposes and says that Affiant is the current owner of the tract of land described in an easement instrument executed by the same on even date herewith, said tract of land is further described as follows:

Restricted Reserve "A" of Lamar CISD Thomas R Culver III Elementary School, a subdivision out of the Angus J. James Survey, Abstract 37, Fort Bend County, Texas, according to the map or plat thereof recorded in Plat No. 20180123 of the Plat Records of said county and state.

Affiant further says that the said premises have been held by Affiant, that possession thereof has been peaceable and undisturbed, and that the title thereto has never been disputed or questioned to Affiant's knowledge, nor does Affiant know of any facts by reason of which said possession or title might be disturbed or questioned, or by reason of which any claim to said premises, or any part thereof, might arise or be set up adverse to this Affiant.

EXECUTED this _____ day of _____, 20____.

Lamar Consolidated Independent School District

BY: _____
Signature

James Steenbergen
Title

Board President
Name typed or printed

SUBSCRIBED and SWORN before me this ____ day of _____, 20____.

Notary's Signature

Name typed or printed

Commission Expires

AFTER RECORDING RETURN TO:
SURVEYING & RIGHT OF WAY
CENTERPOINT ENERGY HOUSTON ELECTRIC, LLC
P. O. BOX 1700
HOUSTON, TX 77251-1700



DETAIL SKETCH

LAMBERT	SECTION	KEY MAP	FUNCTIONAL LOCATION	SCALE	CIRCUIT	ORDER NO.
4345	A2	644K	EXHIBIT "A"	N.T.S.	BC08	86422738

SHEET 2 OF 3
 DETAILS EASEMENTS
 TO BE ACQUIRED AT
 THE TRANSFORMER PAD,
 THE MANHOLE, AND
 FOR THE PRIMARY
 CONDUITS

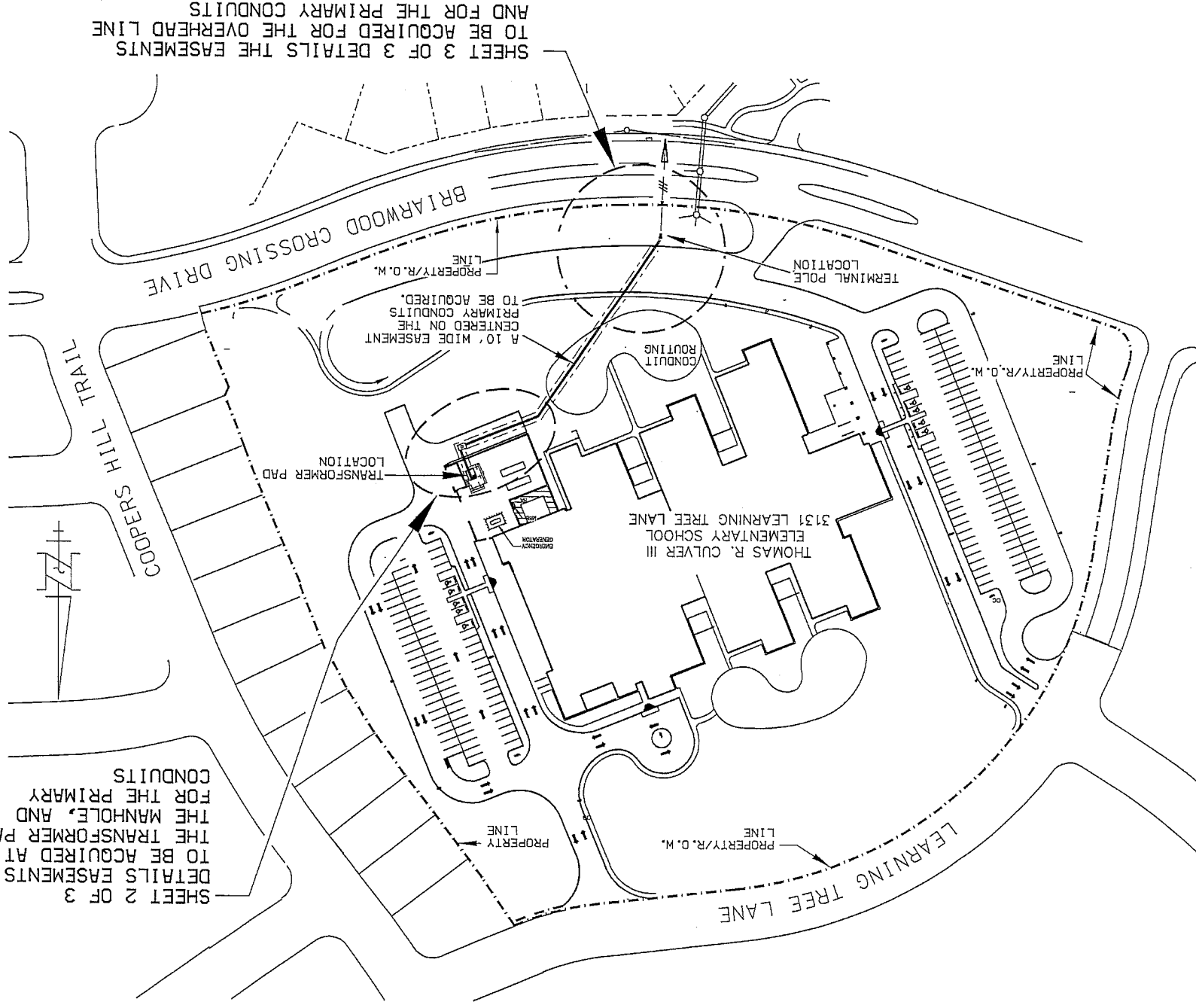

DETAIL SKETCH

LAMBERT	SECTION	KEY MAP	FUNCTIONAL LOCATION	SCALE	CIRCUIT	ORDER NO.
4345	A2	644K	EXHIBIT "A"	N. T. S.	BC08	86422738

TERMINAL POLE DETAIL

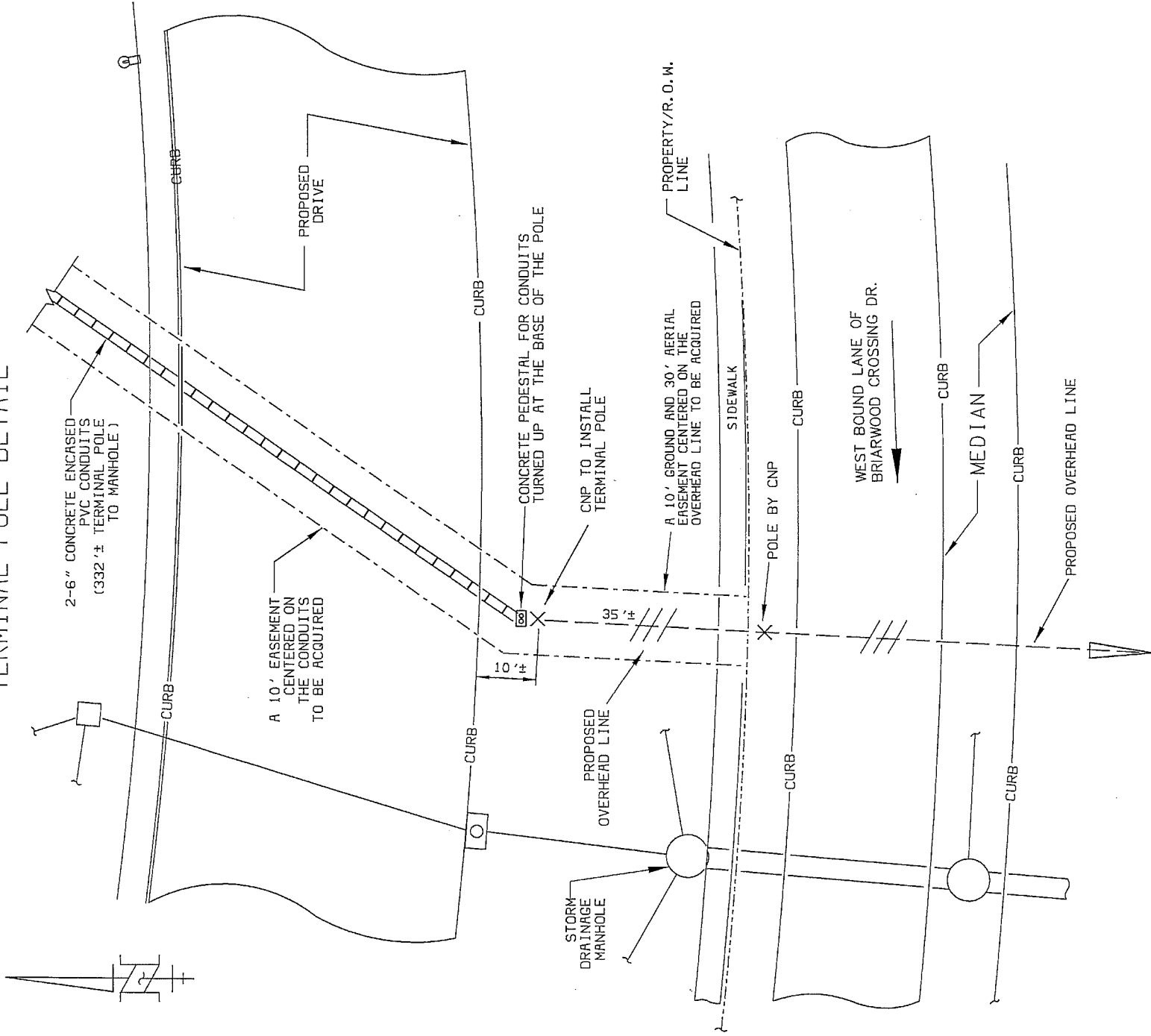

**CONSIDER APPROVAL OF CENTERPOINT ENERGY
FACILITIES EXTENSION AGREEMENT FOR ROBERTS MIDDLE SCHOOL**

RECOMMENDATION:

That the Board of Trustees approve the CenterPoint Energy facilities extension agreement for the installation of electric service at Roberts Middle School in the amount of \$3,800 and authorize the Board President to execute the agreement documents.

IMPACT/RATIONALE:

The facilities extension agreement is required to be executed for CenterPoint Energy to provide electric service for Roberts Middle School.

These funds were allocated within the 2014 Bond Budget.

PROGRAM DESCRIPTION:

Upon approval, the Board President will execute the agreement documents and CenterPoint Energy will begin design and installation of the permanent electrical service for Roberts Middle School.

Submitted By: Leslie Haack, Deputy Superintendent of Support Services
Kevin McKeever, Executive Director of Facilities & Planning
Steve Hoyt, Vanir/Rice & Gardner Consultants, Inc., A Joint Venture

Recommended for approval:



Dr. Thomas Randle
Superintendent

CenterPoint Energy Houston Electric, LLC
Applicable: Entire Service Area

(6-2012)

CNP 8038

6.3 AGREEMENTS AND FORMS

6.3.1 FACILITIES EXTENSION AGREEMENT

This Facilities Extension Agreement is entered into by and between Lamar Consolidated Independent School District, herein called "Retail Customer" and CenterPoint Energy Houston Electric, LLC, herein called "Company" (hereinafter referred to as Agreement) for the construction, extension, installation, modification, repair, upgrade, conversion, relocation, de-energization or removal of Company's Delivery System, including temporary facilities (hereinafter referred to as facilities extension or extension), as described herein.

This Agreement covers the facilities extension to Retail Customer location at 9230 Charger Way, Fulshear, TX 77441.

The Company agrees to accept payment of \$3,800.00 Dollars to be paid by the Retail Customer, as a Non-Refundable Construction Payment in connection with the Retail Customer request to extend Company facilities to the above described location as follows: The installation of underground facilities, as detailed in the Terms and Conditions Job# 85126434. This agreement includes no cost for the extension, modification or removal of the existing overhead facilities. Please contact the Company's respective Service Center representative for any additional costs that may be associated with this project.

- Unless otherwise stated by Company in writing, the Non-Refundable Construction Payment amount above is valid for twelve months.

In consideration of said Non-Refundable Payment, to be paid to Company by Retail Customer prior to commencement of construction, Company agrees to install and operate lines and equipment necessary to distribute electric service to the identified location under the following General Conditions:

- Company shall at all times have title to and complete ownership and control over facilities installed by Company.
- Retail Customer must make satisfactory payment arrangements (if payment is required to extend Company facilities) and sign and return this Agreement before Company can proceed with the requested extension.

CenterPoint Energy Houston Electric, LLC
Applicable: Entire Service Area

CNP 8038

- Extension of service facilities is contingent on acquisition of all necessary easements and rights of way.

Nothing herein contained within this Agreement shall be construed as a waiver or relinquishment by Company of any right that it has or may hereafter have to discontinue service for or on account of default in the payment of any bill owing or to become owing thereafter for any other reason or cause stated in Company's Tariff.

This Agreement shall not be binding upon Company unless and until it is signed by an authorized representative of the Company.

CenterPoint Energy Houston Electric, LLC

Lamar Consolidated Independent School District

Retail Customer

By _____

By _____

Signature

Latanya Joubert

James Steenbergen

Name printed or typed

Name printed or typed

Title Engineering Technologist

Title Board President

Date June 19, 2018

Date August 16, 2018

**TERMS AND CONDITIONS
UNDERGROUND ELECTRIC SERVICE**

FOR

LAMAR CONSOLIDATED INDEPENDENT SCHOOL DISTRICT

**James W. Roberts Middle School
9230 Charger Way, Fulshear, TX 77441**

Job #85126434
REVISION #1

**CenterPoint Energy
Major Underground Projects
P. O. Box 1700; Houston, Texas 77251-1700**

REFERENCE LAMAR CONSOLIDATED INDEPENDENT SCHOOL DISTRICT DRAWINGS:

Site Plan	Drawing #:	<u>C3.01</u>	Received:	<u>February 8, 2018</u>
Utility Plan	Drawing #:	<u>C3.01</u>	Received:	<u>February 8, 2018</u>
Electrical One-Line	Drawing #:	<u>E5.01</u>	Received:	<u>February 8, 2018</u>
Load Analysis	Drawing #:	<u>E5.01</u>	Received:	<u>February 8, 2018</u>

REFERENCE CENTERPOINT ENERGY SPECIFICATIONS:

Service Standards	:	May 1, 2016
Emergency Generators	:	007-231-82
Ready-Mix Concrete	:	007-221-01
Harmonic Distortion	:	007-231-83

Reviewed And Agreed To By: _____ Board President _____ 08/16/2018
Signature Title Date

James Steenberg
Print Name

If this Terms and Conditions package is signed by anyone other than an official from **Lamar Consolidated Independent School District**, it will not be considered valid. A valid signature will be considered an acceptance of all information contained within this Terms and Conditions package.

CenterPoint Energy Houston, Texas		
WRITTEN	LDJ	5/8/2018
CHECKED	LAO	5/8/2018
APPROVED	LAO	5/8/2018
SHEET 1 OF 14 SHEETS		
PM 4290		

NO.	DATE	ITEMS REVISED	BY	CH	APP
1	6/19/2018	transformer location	LDJ	LAO	LAO

GENERAL

- A. These Terms and Conditions are for a service arrangement for Lamar Consolidated Independent School District. Lamar Consolidated Independent School District and/or its contractors/representatives are herein referred to as the Customer.
- B. Service to be provided by CenterPoint Energy (CNP) from a 750 kVA, 34.5 kV - 480Y/277 V, three phase, four wire, pad mounted transformer.
- C. The CNP Major Underground Projects (MUG) representative is Latanya Joubert at 713-207-6242 or LaTanya.Joubert@centerpointenergy.com.
- The CNP Service Area Consultant is Benjamin J Kresta at 281-391-5114.
- D. The Customer must comply with all CNP Service Standards, the National Electrical Code, the National Electrical Safety Code, all Occupational Safety and Health Administration (OSHA) requirements, the International Building Code and all local governing body codes.
- E. During installation of CNP equipment, CNP will make every effort to preserve the Customer's landscaping, parking areas, or other facilities. However, any cost that has been quoted to the Customer does not include any special replacements or repairs to these items. The Customer shall be solely responsible for any expenses associated with replacements or repairs to its facilities.
- F. The service arrangement outlined in these Terms and Conditions is based on the Customer drawings referenced on page 1. Any changes in the design as illustrated in the referenced drawings may impact CNP's ability to meet the Customer's requested service date.
- G. Any changes, additions, deletions, rearrangements, relocations, rerouting, reduction of clearances, etc., of the Customer's and/or CNP's service facilities illustrated in these Terms and Conditions shall have MUG's approval and may require a revised Terms and Conditions. It is the Customer's responsibility to coordinate the location of all Customer installed facilities outlined in these Terms and Conditions with all other structures and/or appurtenances not shown in the referenced drawings.
- H. Contact the MUG representative concerning Customer drawing revisions, information submission, questions, Terms and Conditions revision requests, etc.
- I. Hard copy submittals may be mailed to the MUG representative (address – 3000A Harrisburg Blvd. – Houston, Texas 77003). Electronic submittals may be e-mailed to the MUG representative. The MUG representative will; “approve the submittals”, “approve the submittals as noted” or “not approve the submittals”. The Customer shall not install any item that requires CNP approval before receiving an official approval from MUG. CNP shall not be responsible for any installed item that has not received MUG approval.

SERVICE CONNECTION

- A. The Customer's maximum number of secondary cables that can be terminated in CNP's pad mount transformer is 8-750 MCM cables per phase. The Customer shall advise the MUG representative, about the type, size and number of secondary conductors. Ampacity equivalent sets of cable must be individually approved by the MUG representative prior to installation by the Customer. If the Customer's cable requirements exceed this specified maximum limit, it cannot be served directly from the pad mounted transformer. The Customer shall then install, own, and maintain a cable tap box (CTB) (See Section D).
- B. On installations not utilizing a CTB, the Customer shall furnish, own, and maintain all secondary service conduit and cable underground into the secondary opening of the transformer pad. Secondary conductors shall be extended a minimum of seven feet (7') above the transformer pad. **The Customer shall not install the secondary cables until after the transformer has been set. CNP will terminate the secondary cables in the transformer.**
- C. To accommodate future expansion, the Customer may install up to 14-4" secondary conduits into the transformer pad.
- D. On installations utilizing a CTB, CNP shall furnish, own, install and terminate the secondary cable from the transformer to the CTB at the Customer's expense. The Customer shall furnish, install, own and maintain the CTB, the CTB pad, and 14-4" conduits from the secondary opening of the transformer pad to the CNP side of the CTB pad. The Customer shall install and terminate the secondary cable from its side of the CTB to its switchgear. Typical three-phase CTB drawings are available upon request. The Customer shall submit three (3) drawings of the proposed CTB to the MUG representative for approval prior to fabrication.
- E. The initial available short circuit current is 16,957 amperes symmetrical, with an X/R ratio of 8.0.
- F. The ultimate available short circuit current is 56,523 amperes symmetrical, with an X/R ratio of 9.6.
- G. Customers receiving electrical service from multiple sources will be required to install a permanent plaque or directory at each source in accordance with Article 230.2 of the National Electrical Code (NEC). These plaques are to signify that there is more than one electrical service to the building. The Customer shall keep the power from each source separate throughout its entire electrical system. This requirement is for the life of the service.
- H. A protective device coordination study for the Customer's service relative to CNP's protective devices may be requested by contacting the MUG representative.

ACCESS

The Customer must provide a twelve foot (12') minimum width, fourteen foot (14') minimum vertical clearance, all weather, vehicle access road designed for HS-20-44 loading as recognized by the American Association of State Highway Officials (AASHO), for CNP personnel and equipment ten feet (10') past the side of the proposed pad mounted equipment location. In addition, the area adjacent to the pad must be designed for HS-20-44 loading to allow for outrigger placement. If the access road and the pad mounted equipment location have not been completed and passed final inspection (see Final Inspection, page 7) at the time the Customer requests the equipment be set, the equipment can only be set under the following conditions.

- A. MUG has determined that the access route is dry and readily accessible to CNP's normal installation equipment.
- B. The Customer shall be responsible for all expenses associated with the repair and/or replacement of CNP pad mounted equipment damaged by additional construction activity. Damage to CNP equipment may result in delays to the Customer's requested service date.
- C. CNP will not complete the underground construction (i.e. pulling & terminating cable, energizing the service, etc.) until the access road and pad mounted equipment location have passed final inspection (see Final Inspection, page 7).

The Customer must provide a thirty two foot (32') minimum vertical clearance over all equipment pads for CNP trucks and equipment.

The Customer must maintain these requirements for the life of the service.

CNP will utilize the Customer's parking and driveway facilities for the required access.

EMERGENCY GENERATION AND SECONDARY LOAD TRANSFER

Customer installed Emergency Generators and/or Secondary Load Transfer schemes shall meet the requirements of the CNP Specification on Customer Emergency Generation and Secondary Load Transfer, Specification 007-231-82, latest revision (attached). This requirement is for the life of the service.

Generator exhaust must be located and/or directed away from CNP's equipment.

HARMONIC DISTORTION

The Customer shall meet the requirements of the CNP Specification on Limitation of Harmonic Distortion on the Distribution System, Specification 007-231-83, latest revision (available upon request). This requirement is for the life of the service.

METERING

- A. The Customer's metering arrangement must comply with CNP Service Standards, Section 400 or 500 as applicable.
- B. The metering current and potential transformers (CT's and PT's) will be installed in the secondary compartment of the transformer provided all service from the transformer is through one meter. If all the services are not through one meter, the Customer shall inform the MUG representative, so that alternate metering provisions can be arranged (separate CT and PT cans as required for each service).
- C. All Retail Customers must be metered separately.
- D. Meter Room and/or Modular Meter installations must have CNP written approval prior to the purchase/installation of materials/equipment. The Customer must submit applicable drawings to the MUG representative for approval.

FACILITIES INSTALLED BY THE CUSTOMER

All facilities are to be installed per the attached construction specifications. The Customer or its contractor is to request a preconstruction meeting prior to starting the required underground construction by calling the number listed below.

All facilities shall be inspected by CNP after the conduit is installed, pads are formed, reinforcing rods installed, etc. but prior to the pouring of concrete. CNP recommends that the Customer complete the pouring of concrete on the day the facilities are inspected and approved. The Customer will insure that all inspected and approved facilities remain in the approved condition until the concrete pour has been completed. If there is damage to the inspected and approved facilities prior to the pouring of concrete, the facilities must be re-inspected by CNP before the Customer begins the pouring of concrete. CNP reserves the right to require the Customer to break out any unapproved concrete pours at its expense.

CNP will make a reasonable attempt to complete all inspection requests. To ensure that inspection requests can be fulfilled, they should be made prior to 5 p.m. the business day before the requested inspection to Major Underground Projects at <http://www.centerpointenergy.com/en-us/pages/mugform.aspx>. Job # 85126434 must be provided as the inspection identification number.

DUCTBANK INSTALLATION

All proposed conduit for CNP's use is to be installed in straight runs, unless otherwise indicated on CNP drawings. Any conduit bends must be installed with a twenty foot (20') minimum radius, unless indicated otherwise on CNP drawings. Conduit turn-ups into any equipment pad and/or pole pedestal must have a minimum five foot (5') radius. Any deviations from these requirements shall have written approval from the MUG representative prior to installation.

During installation, the minimum depth for a conduit run must be referenced to the final grade.

The Customer is to delay installation of approximately the last twenty feet (20') of the conduit run and the pole pedestal to any terminal pole until the pole has been set by CNP. Before trenching to the base of any terminal pole, the Customer must securely brace the pole. The Customer must request staking and setting of any terminal pole by contacting the Service Area Consultant.

DUCTBANK INSTALLATION (continued)

The Customer must provide a jet line in each conduit installed. This jet line shall extend a minimum of seven feet (7') beyond the end of each conduit.

For installations not utilizing a blanket easement document (see Easement Instrument section, page 7), the Customer shall also install a #14 American Wire Gage (AWG) or larger aluminum or copper 600 volt insulated conductor in one of the conduits. The conductor must be electrically continuous. For manhole installations, the electrically continuous conductor must also be looped through each manhole lid and tied to a concrete insert in the neck of each manhole. This conductor is to facilitate surveying of the duct bank by CNP. The duct bank cannot be surveyed until this conductor is installed as prescribed. The Customer must take adequate measures to assure the conductor will be in place until all necessary surveying is completed. After surveying of the duct bank is completed, but prior to CNP installing any primary cable, the Customer may retrieve its conductor at its option.

Conduit ends shall be plugged with a duct cap or other type capping device. The use of rags to plug conduits is not acceptable. If the conduit is installed in stages, the Customer must keep each section of conduit capped until the new section is installed. If, prior to CNP using any conduit, the conduit is found to be blocked, the Customer will be responsible, at its expense, for removing the obstruction.

CLEARANCES

Final approval for the location of the pad mount equipment and/or other proposed electrical installation is contingent upon proper clearance, as determined by CNP, from cooling towers, vents, buildings, structures, etc., and other underground utilities. It is in the Customer's and CNP's best interest to have all service equipment in a contamination-free environment to avoid unscheduled outages and/or premature equipment failures. Therefore, prior to any construction, the Customer shall inform the MUG representative of any existing or future contamination or pollutants which may affect the equipment so that necessary clearances can be secured.

The MUG representative shall be notified promptly if the Customer intends to install any obstructions such as walls, hedges, bushes, trees, etc., around the transformer and/or any associated equipment so that additional clearances and access can be secured. Any proposed enclosure surrounding CNP's equipment must be louvered, and both a profile and a cross-sectional view of the proposed louvered enclosure shall be submitted for approval prior to installation.

If, in the future, there is a problem with contamination of CNP's equipment, or proper clearances are not maintained, CNP reserves the right to relocate the equipment at the Customer's expense.

CNP will not allow other facilities to pass beneath its equipment pads. A one foot (1') minimum horizontal clearance shall be maintained between CNP pads and all other facilities.

A one foot (1') minimum vertical clearance must be maintained between CNP duct banks and all non-CNP facilities crossing the duct bank.

A five foot (5') minimum horizontal clearance must be maintained between CNP duct banks and other facilities running parallel to the duct bank. CNP will not allow joint trenching between CNP duct banks and other facilities.

ELEVATION REQUIREMENTS

The minimum elevation requirement for the top of the equipment pads shall be fifteen feet (15') above mean sea level and eighteen inches (18") above the documented 100-year floodplain. The Customer must provide equipment pads that meet these elevation requirements. The easement (minimum working clearance) around the equipment pads shall also be brought up to the above mentioned minimum elevation, as outlined on the equipment pad detail specification. The easement area surrounding the equipment pads shall not have a slope greater than 2%. The pad and minimum easement elevations (minimum working clearance) must be verified at the time installation.

VENTILATION REQUIREMENTS

Any proposed barriers or enclosures in the vicinity of the equipment pads shall maintain a minimum of 50% free air flow. Prior to construction, the Customer shall submit drawings of the proposed barriers or enclosures to MUG Projects Representative for approval.

FINAL INSPECTION

After the Customer has advised CNP that all "Customer installed" facilities pertaining to this service arrangement have been completed and inspected, a final on-site inspection will be made by a MUG representative. This final inspection will verify that all Customer installed facilities are in accordance with these Terms and Conditions. The Customer (or its contractor) and the Service Area Consultant will be advised of any needed corrections and/or changes. When all necessary corrections and/or changes have been completed, CNP's portion of the construction may begin.

EASEMENT INSTRUMENT

CNP will prepare an instrument for easements to be granted by the property owner after all installations for CNP's use have been completed according to these Terms and Conditions. The service cannot be energized until CNP has accepted the signed instrument for all easements.

The Customer also has the option of signing a blanket easement document. Use of the blanket easement allows the service to be energized before the final signed instrument for all easements has been completed. The Customer may request use of the blanket easement document by contacting the MUG representative.

CNP will need access to and from the proposed easements. CNP will use these easements, as shown on the attached sketches, for the purposes of erecting, installing, operating, maintaining, replacing, inspecting and removing electrical distribution facilities. The Customer shall keep these easements free and clear of any obstructions (trees, shrubs, other structures, etc.) that may endanger or interfere with the efficiency, safety, and proper operation of the proposed facilities for the life of the service.

INDEMNIFICATION AND LIABILITY LIMITS

Indemnity: This indemnity is pursuant to Company's Tariff located on our website at www.centerpointenergy.com.

RETAIL CUSTOMER ASSUMES THE RISK OF AND SHALL INDEMNIFY COMPANY AGAINST DAMAGES FOR INJURIES OR DEATH TO PERSONS OR LOSS TO RETAIL CUSTOMER'S PROPERTY, OR TO THE PROPERTY OF COMPANY, WHEN OCCASIONED BY ACTIVITIES OF RETAIL CUSTOMER OR THIRD PARTIES ON CUSTOMER'S PREMISES, RESULTING FROM THE INSTALLATION, EXISTENCE, REPLACEMENT, OR REPAIR OF COMPANY'S UNDERGROUND FACILITIES, AND AS FURTHER PROVIDED IN THE TERMS OF "LIMITS ON LIABILITY," SECTIONS 4.2 AND 5.2 OF THIS TARIFF. NOTWITHSTANDING ANY OF THE ABOVE, THE PROVISIONS REQUIRING A RETAIL CUSTOMER TO INDEMNIFY, FULLY PROTECT, OR SAVE COMPANY HARMLESS APPLY TO A GOVERNMENTAL ENTITY AS THIS TERM IS DEFINED IN CHAPTER 2251 OF THE TEXAS GOVERNMENT CODE, TO THE EXTENT OTHERWISE CONSISTENT WITH LAW; PROVIDED, HOWEVER, THAT ANY GOVERNMENTAL ENTITY THAT IS A RETAIL CUSTOMER TO WHICH THIS SUBSECTION 2.5 APPLIES MUST TAKE NECESSARY STEPS TO ENSURE THAT THE INDEMNIFICATION REQUIREMENTS OF THIS SUBSECTION 2.5 DO NOT CREATE A "DEBT" IN VIOLATION OF ARTICLE XI, SECTION 7 OF THE TEXAS CONSTITUTION. SUCH STEPS MAY INCLUDE, BUT ARE NOT NECESSARILY LIMITED TO, A THIRD-PARTY INDEMNIFICATION IN WHICH THE CONTRACTOR PERFORMING THE WORK FOR THE GOVERNMENTAL ENTITY INDEMNIFIES THE COMPANY OR THE ESTABLISHMENT OF A SINKING FUND. *(See Governmental Entity Addendum if applicable.)*

GENERAL LOCATION SKETCH

LAMBERT	SECTION	KEY MAP	FUNCTIONAL LOCATION	SCALE	CIRCUIT	ORDER NO.
4154	D1	523J	N. T. S.	FL42		

LAMAR CONSOLIDATED INDEPENDENT SCHOOL DISTRICT (CUSTOMER) AND/OR ITS CONTRACTOR IS TO REQUEST A PRECONSTRUCTION MEETING PRIOR TO STARTING CONSTRUCTION BY VISITING [HTTP://WWW.CENTERPOINTENERGY.COM/EN-US/PAGES/MUGFORM.ASPX](http://www.centerpointenergy.com/en-us/pages/mugform.aspx)

CENTERPOINT ENERGY (CNP) TO UTILIZE THE CUSTOMER'S PARKING AND DRIVEWAY FACILITIES FOR EQUIPMENT ACCESS

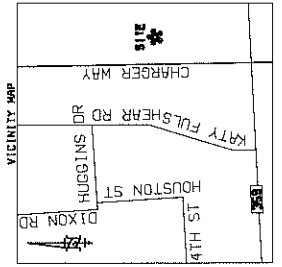
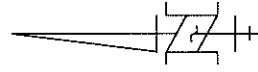
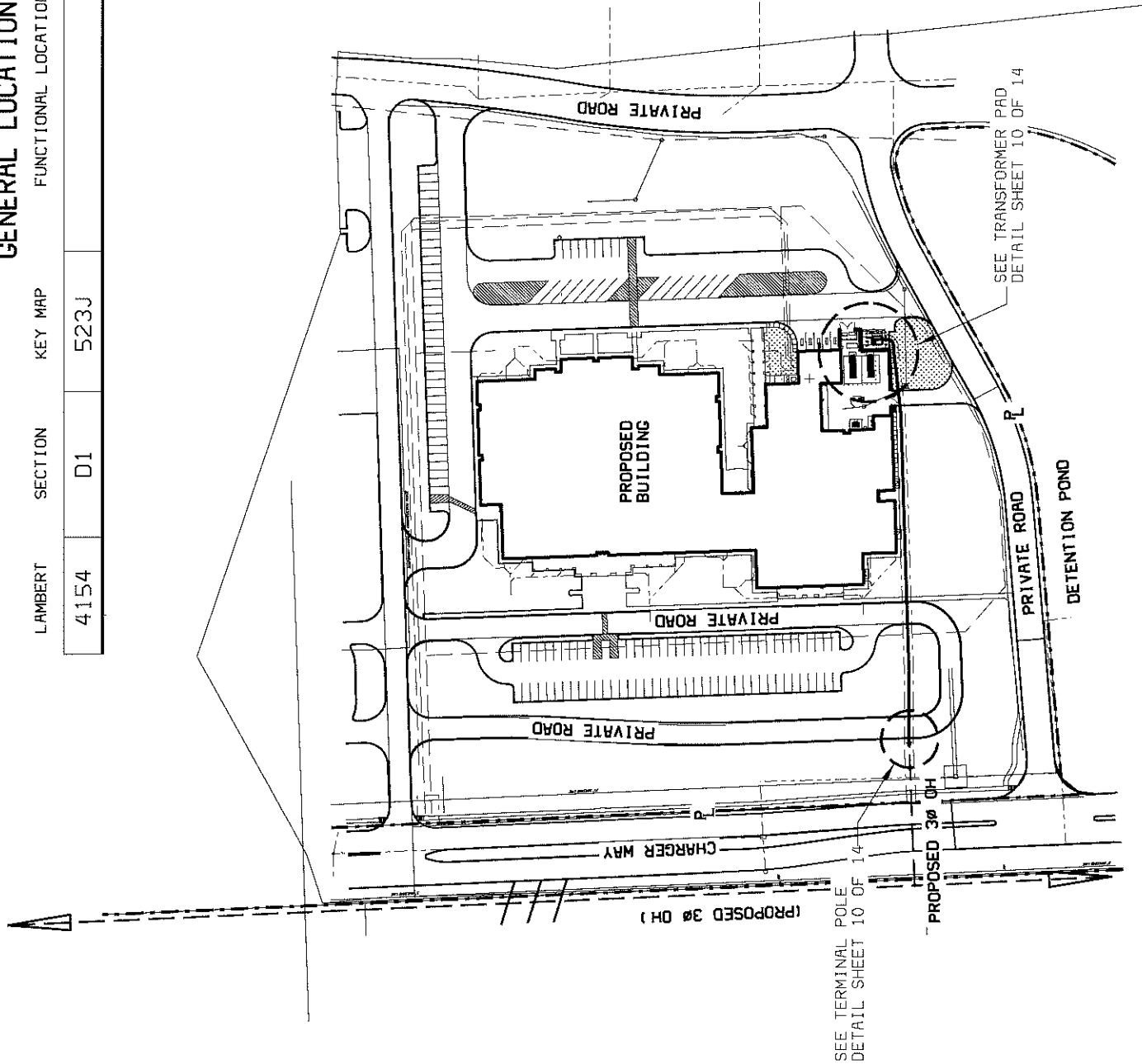

LAMBERT	SECTION	KEY MAP	FUNCTIONAL LOCATION	SCALE	CIRCUIT	ORDER NO.
4154	D1	523J		N. T. S.	FL42	

DETAIL SKETCH

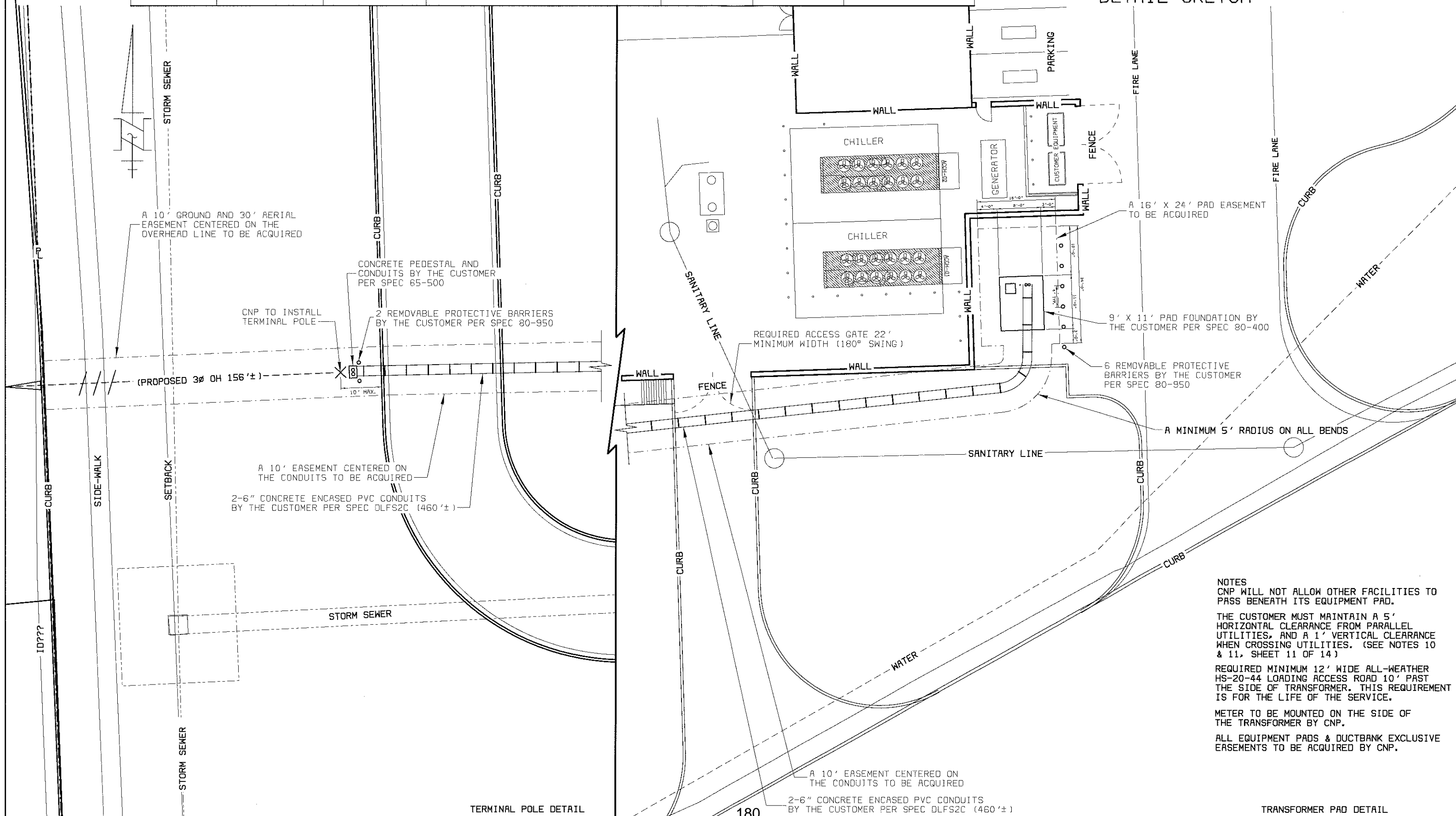

A 10' GROUND AND 30' AERIAL EASEMENT CENTERED ON THE OVERHEAD LINE TO BE ACQUIRED

CONCRETE PEDESTAL AND CONDUITS BY THE CUSTOMER PER SPEC 65-500

CNP TO INSTALL TERMINAL POLE

2 REMOVABLE PROTECTIVE BARRIERS BY THE CUSTOMER PER SPEC 80-950

(PROPOSED 3Ø OH 156'±)

A 10' EASEMENT CENTERED ON THE CONDUITS TO BE ACQUIRED

2-6" CONCRETE ENCASED PVC CONDUITS BY THE CUSTOMER PER SPEC DLFS2C (460'±)

REQUIRED ACCESS GATE 22' MINIMUM WIDTH (180° SWING)

A 16' X 24' PAD EASEMENT TO BE ACQUIRED

9' X 11' PAD FOUNDATION BY THE CUSTOMER PER SPEC 80-400

6 REMOVABLE PROTECTIVE BARRIERS BY THE CUSTOMER PER SPEC 80-950

A MINIMUM 5' RADIUS ON ALL BENDS

NOTES
CNP WILL NOT ALLOW OTHER FACILITIES TO PASS BENEATH ITS EQUIPMENT PAD.

THE CUSTOMER MUST MAINTAIN A 5' HORIZONTAL CLEARANCE FROM PARALLEL UTILITIES, AND A 1' VERTICAL CLEARANCE WHEN CROSSING UTILITIES. (SEE NOTES 10 & 11, SHEET 11 OF 14)

REQUIRED MINIMUM 12' WIDE ALL-WEATHER HS-20-44 LOADING ACCESS ROAD 10' PAST THE SIDE OF TRANSFORMER. THIS REQUIREMENT IS FOR THE LIFE OF THE SERVICE.

METER TO BE MOUNTED ON THE SIDE OF THE TRANSFORMER BY CNP.

ALL EQUIPMENT PADS & DUCTBANK EXCLUSIVE EASEMENTS TO BE ACQUIRED BY CNP.

A 10' EASEMENT CENTERED ON THE CONDUITS TO BE ACQUIRED

2-6" CONCRETE ENCASED PVC CONDUITS BY THE CUSTOMER PER SPEC DLFS2C (460'±)

TERMINAL POLE DETAIL

TRANSFORMER PAD DETAIL

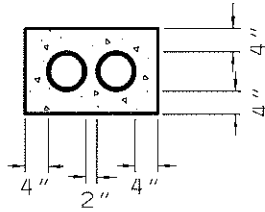
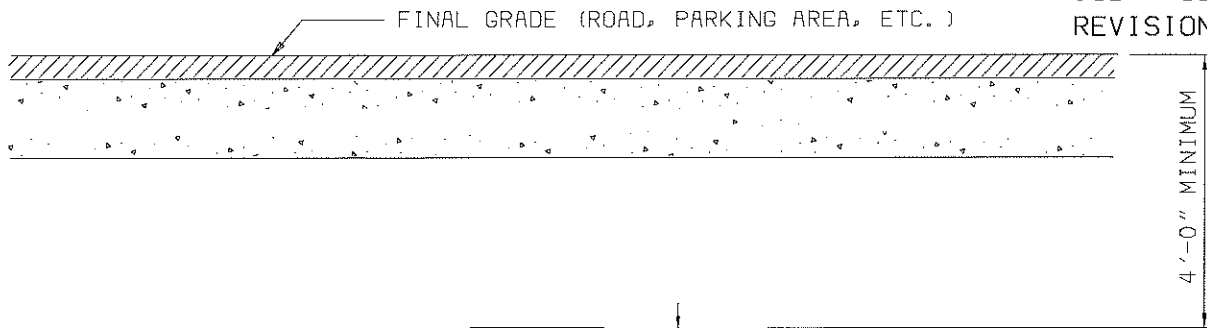

2 - 6"
CONDUITS

NOTE:
 THE CUSTOMER AND/OR ITS CONTRACTOR
 IS TO REQUEST A PRECONSTRUCTION MEETING
 PRIOR TO STARTING CONSTRUCTION BY VISITING
[HTTP://WWW.CENTERPOINTENERGY.COM/EN-US/PAGES/MUGFORM.ASPX](http://www.centerpointenergy.com/en-us/pages/mugform.aspx)

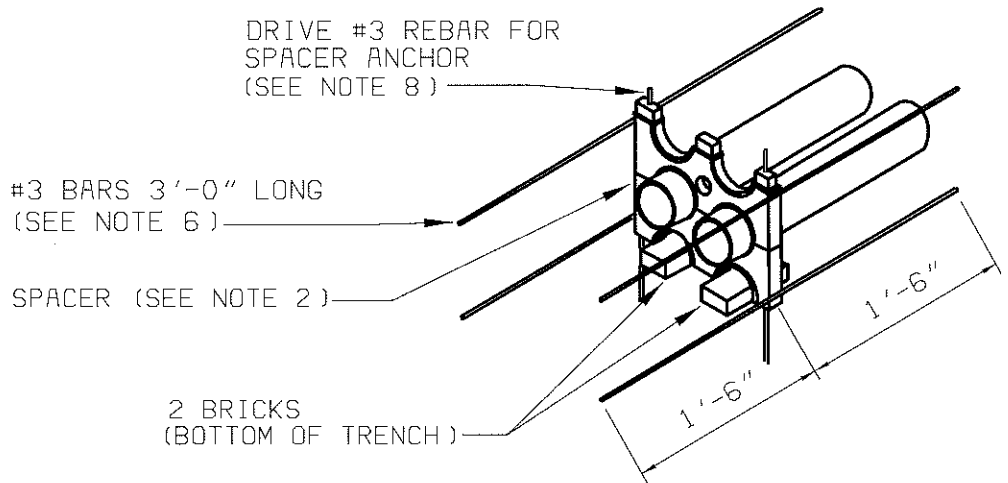

DRIVE #3 REBAR FOR
SPACER ANCHOR
(SEE NOTE 8)

#3 BARS 3'-0" LONG
(SEE NOTE 6)

SPACER (SEE NOTE 2)

2 BRICKS
(BOTTOM OF TRENCH)

NOTES:

1. CONDUIT TO BE PVC, MINIMUM GRADE TYPE EB.
2. SPACERS SHOULD BE INSTALLED NOT MORE THAN 10'-0" APART.
3. CONDUITS TERMINATING AT MANHOLES SHOULD BE SLOPED 0.5% DOWN TOWARD MANHOLE.
4. ALL EXTERIOR CONCRETE COVER DIMENSIONS ARE MINIMUM.
5. CONCRETE SHALL BE IN ACCORDANCE WITH CNP SPECIFICATION 007-221-01, LATEST REVISION.
6. PLACE REINFORCING BARS IN 4 CORNERS OF THE CONCRETE WHERE SPACERS ARE USED.
7. ON COLD JOINT CONCRETE POUR USE #5 REBAR (3'-0" IN LENGTH, EXPOSED 1'-6").
8. LENGTH OF REBAR FOR SPACER ANCHOR WILL VARY PER DUCT BANK HEIGHT.
9. CONDUITS ENDS SHALL BE PLUGGED WITH A DUCT CAP OR OTHER TYPE OF CAPPING DEVICE.
10. A ONE FOOT (1') VERTICAL CLEARANCE MUST BE MAINTAINED BETWEEN CNP'S DUCTBANK AND ALL NON-CNP FACILITIES CROSSING THE DUCTBANK.
11. A FIVE FOOT (5') HORIZONTAL CLEARANCE MUST BE MAINTAINED BETWEEN CNP'S DUCTBANK AND ALL NON-CNP FACILITIES RUNNING PARALLEL TO THE DUCTBANK (JOINT TRENCHING NOT PERMITTED).
12. INSTALL JET LINE IN ALL CONDUITS AND A #14 AWG WIRE IN ONE CONDUIT.

THREE PHASE DUCTBANK
FEEDER

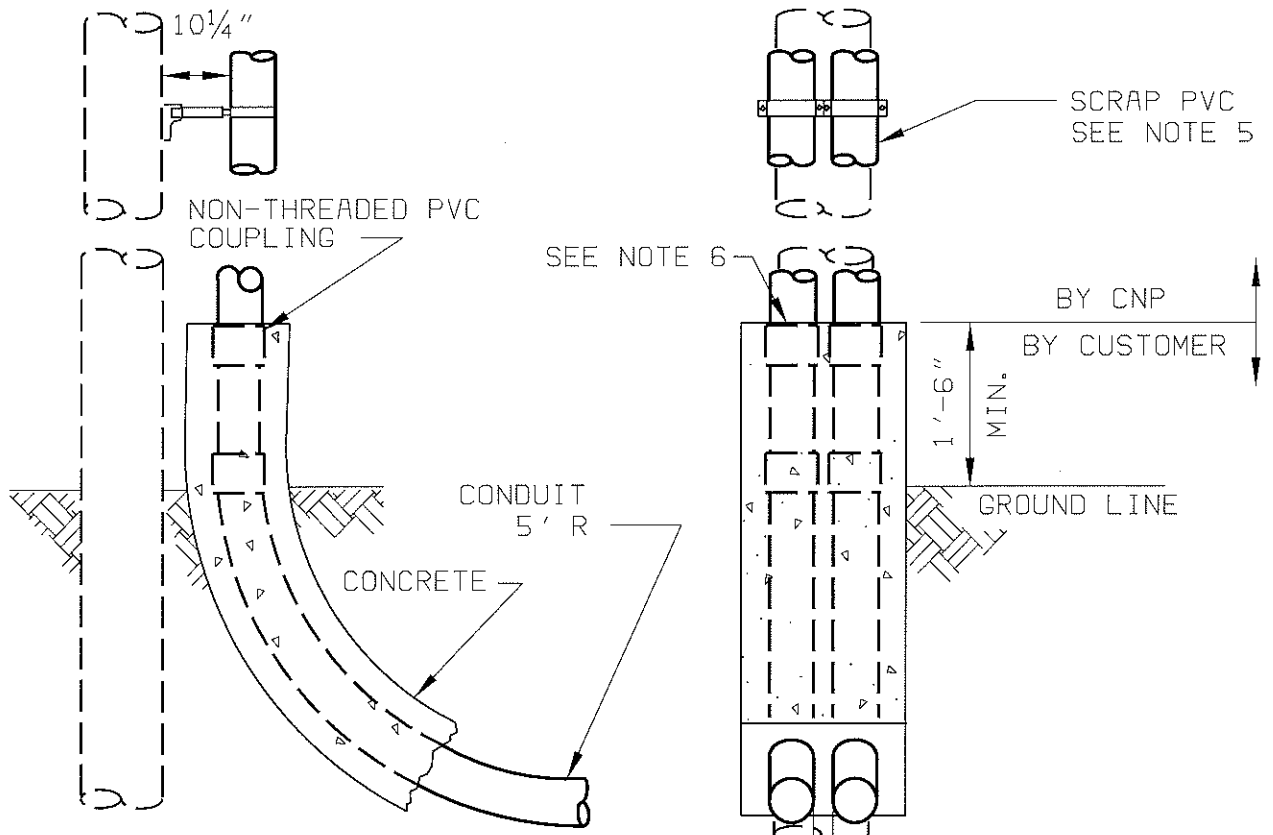

INLINE PLACEMENT OF CONDUIT

NOTES:

1. CONDUIT BENDS AT TERMINAL POLE SHALL BE PVC.
2. BRACE THE POLE SECURELY BEFORE TRENCHING.
3. INSTALL CONDUIT BENDS TO BASE OF POLE. ADD PORTIONS OF STRAIGHT CONDUIT AS NECESSARY TO OBTAIN THE PROPER HEIGHT ABOVE FINAL GRADE.
4. ATTACH COUPLING TO END OF CONDUIT.
5. INSERT, **BUT DO NOT GLUE**, A SHORT PIECE OF SCRAP PVC BUT DO NOT GLUE CONDUIT INTO THE TOP COUPLING. TIE CONDUIT TO BRACKET.
6. FORM AREA AROUND PEDESTAL TO THE TOP OF THE COUPLING. FORM PEDESTAL SO THAT NO CONCRETE WILL CONTACT POLE.
7. AFTER INSPECTION BY CNP, POUR CONCRETE TO TOP OF COUPLINGS.
8. ALL CONDUITS SHALL HAVE A MINIMUM 4" CONCRETE COVER.

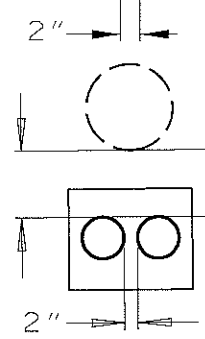

**TERMINAL POLE CONDUIT
 PLACEMENT 12KV & 35 KV**

030486/060807

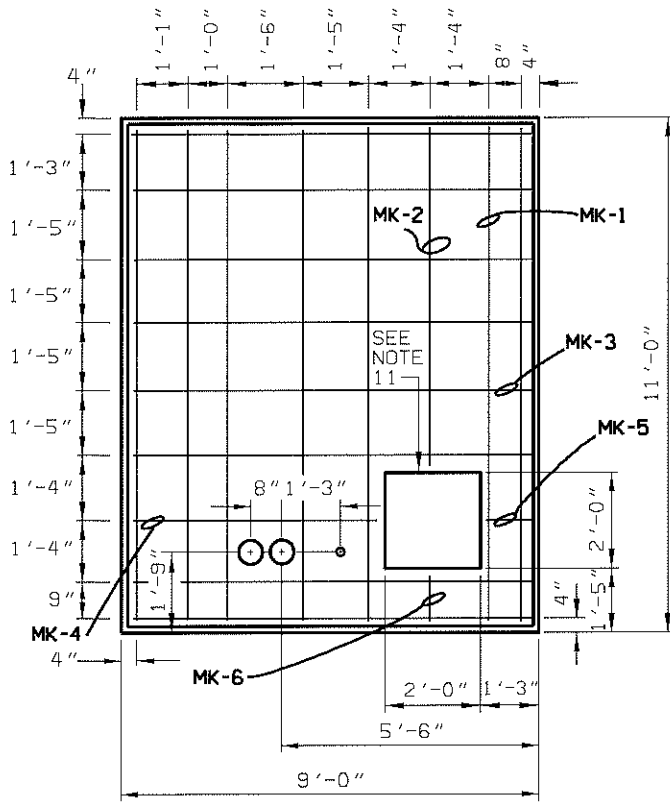

REINFORCING SCHEDULE PER FOUNDATION				
MARK	QTY.	SIZE	LENGTH	REMARKS
MK-1	14	#7	10'-6"	STRAIGHT
MK-2	2	#7	7'-0"	STRAIGHT
MK-3	16	#7	8'-6"	STRAIGHT
MK-4	2	#7	5'-3"	STRAIGHT
MK-5	2	#7	0'-9"	STRAIGHT
MK-6	2	#7	1'-0"	STRAIGHT

MATERIAL ESTIMATE PER FOUNDATION	
DESCRIPTION	QUANTITY
REINFORCING STEEL #7	636 LBS
CONCRETE (5 SACK)	5½ CU. YDS.
TYPE EB OR BETTER PVC CONDUIT, 90 DEG, 60" R	2
2" PVC CONDUIT	5 FT

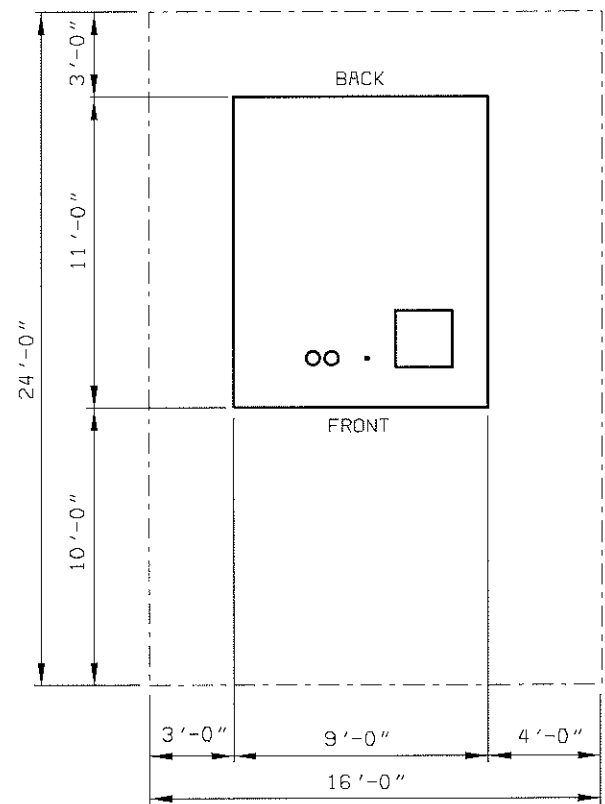
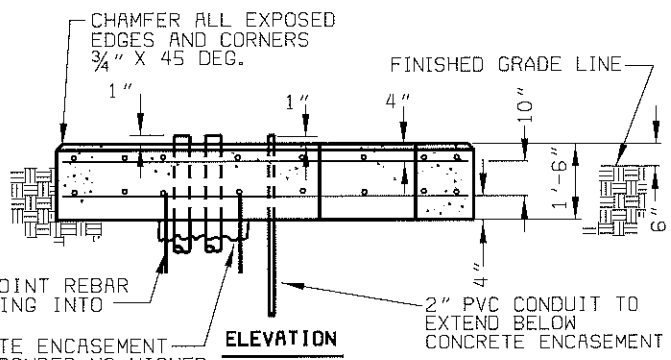

**EQUIPMENT
 WEIGHT 43,000 LBS
 MAXIMUM**

- NOTES:
- CONCRETE SHALL BE IN ACCORDANCE WITH CNP SPECIFICATION 007-221-01, LATEST REVISION (MINIMUM COMPRESSION IN 28 DAYS, 3000 PSI).
 - REINFORCING STEEL SHALL BE INTERMEDIATE GRADE DEFORMED BARS IN ACCORDANCE WITH A.S.T.M. SPECIFICATION A-615, GRADE 60, OR BETTER.
 - ALL SPLICES IN REINFORCING SHALL LAP A LENGTH EQUAL TO 24 BAR DIAMETERS.
 - ALL DIMENSIONS ON REINFORCING ARE TO THE CENTER OF BARS.
 - CONCRETE SHALL BE THOROUGHLY WORKED AROUND REINFORCING, ANY EMBEDDED FIXTURES AND INTO ALL CORNERS OF FORMS.
 - IF REQUIRED, GROUT SHALL BE A MIXTURE OF 1 PART CEMENT TO 2 PARTS SAND WITH ENOUGH WATER TO PRODUCE A WORKABLE MIXTURE.
 - CONCRETE IS TO BE POURED ONLY WHEN THE ATMOSPHERIC TEMPERATURE IS A MINIMUM 40° F. (5° C.) AND RISING.
 - STRIP BACK ALL VEGETATION AND APPROXIMATELY 12" OF TOP SOIL. REMOVE ALL LOOSE CLOUDS AND STONES. BACKFILL AND THOROUGHLY COMPACT ALL CONDUIT TRENCHES AND HOLES BEFORE CONCRETE IS PLACED.
 - REINFORCING SHALL HAVE A MINIMUM OF 2½" CONCRETE COVER. SLOPE PAD 1" FRONT TO BACK.
 - THE SQUARE OPENING IS FOR THE CUSTOMER'S SECONDARY CONDUITS.
 - CNP WILL NOT ALLOW OTHER FACILITIES TO PASS BENEATH ITS EQUIPMENT PADS. A ONE FOOT MINIMUM HORIZONTAL CLEARANCE SHALL BE MAINTAINED BETWEEN CNP PADS AND ALL OTHER FACILITIES.
 - THE SECONDARY OPENING IS TO BACKFILLED WITH SAND TO WITHIN 4" OF THE TOP OF THE PAD.

**500-5000 KVA PMT
 FOUNDATION, 12KV & 35KV**

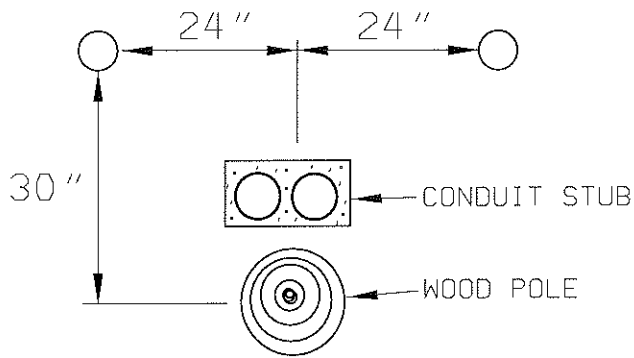
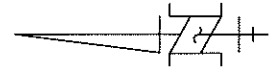

TERMINAL POLE PROTECTIVE BARRIER PLACEMENT

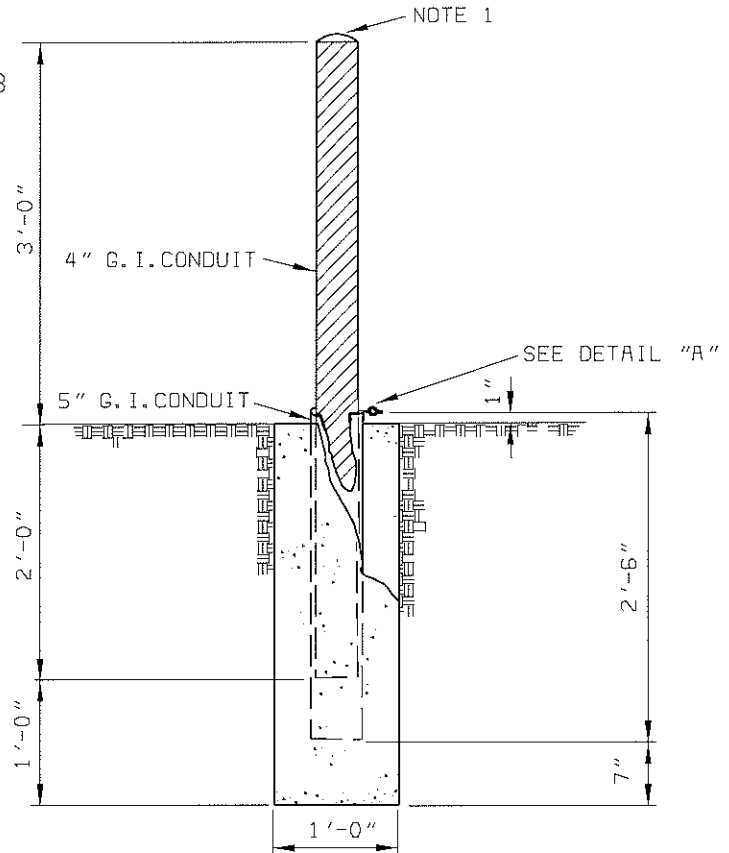

**PROTECTIVE BARRIER
 (REMOVABLE)**

INSTALL ON APPROXIMATELY 4' CENTERS AS SPECIFIED ON SKETCH

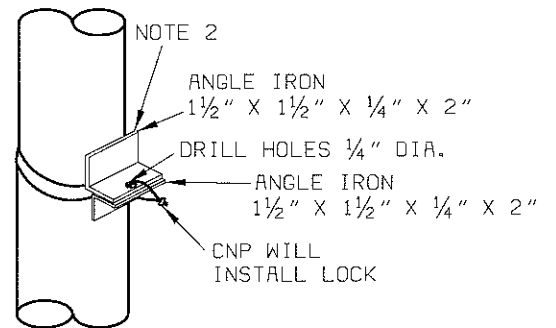

DETAIL "A"

NOTES:

1. 4" G.I. CONDUIT TO BE FILLED WITH CONCRETE.
2. ANGLE TO BE WELDED TO G.I. CONDUIT. ALL EXPOSED METAL TO BE PAINTED WITH GALVANOX PAINT.
3. SEAL GAP BETWEEN CONDUITS WITH DUCT SEAL FOR WATER TIGHT FIT.
4. USE 5" PLUG TO PREVENT CONCRETE FROM COMING UP 5" G.I. CONDUIT.

**PROTECTIVE BARRIER
 (REMOVABLE)**

BASED ON DISTRIBUTION STANDARD 80-950

ADDENDUM TO “TERMS AND CONDITIONS TO UNDERGROUND ELECTRIC SERVICE”

This Addendum is dated as of the Effective Date (as defined below) and is between CENTERPOINT HOUSTON ELECTRIC, LLC (the “Company”) and Lamar Consolidated Independent School District (“Customer”). The Company and Customer are referred to in this Addendum individually as a “Party” and collectively as the “Parties.”

Customer is the owner and operator of James W. Roberts Middle School, 9230 Charger Way, Fulshear, TX 77441 (“Property”). (“Facilities”) shall mean any facilities, equipment, cable, or other material referred to in the Agreement installed and owned by the customer or his contractor at **9230 Charger Way, Fulshear, TX 77441** .

Contemporaneously with the execution of this Addendum, Customer and the Company are entering into THE TERMS AND CONDITIONS TO UNDERGROUND ELECTRIC SERVICE (the “Agreement”) under which underground electric service will be provided to the Facility. “Effective Date” means the date that the Agreement is signed, as indicated by the date next to the customer signature on the cover sheet of the Agreement.

Because of certain laws and regulations applicable to Customer, the Parties desire to set forth their understanding regarding those laws and regulations and the related allocation of certain risks and liabilities between them.

The Parties therefore agree as follows:

1. Applicability. This Addendum is being executed in connection with and will be deemed to be a part of the Agreement. No provision of the Agreement stating that the Agreement contains the entire understanding of the Parties with respect to its subject matter or other provision in the Agreement of the type typically referred to as a “merger clause” will apply to this Addendum. To the extent that the terms and provisions of this Addendum conflict with the terms and provisions of the Agreement, the terms and provisions of this Addendum control. Notwithstanding the execution of this Addendum, the Agreement remains in full force and effect, except as otherwise provided in this Addendum.

2. Customer as Governmental Entity. Customer represents and warrants that it is a governmental entity, and that as a governmental entity it is subject to constitutional and statutory limitations on its ability to be bound by certain terms and conditions of the Agreement, which may include terms and conditions relating to: liens on government property; disclaimers and limitations of warranties; disclaimers and limitations of liability for damages; waivers, disclaimers, and limitations on legal rights, remedies, requirements, commitment of future funding, and processes; limitations of time in which to bring legal action; control of litigation or dispute resolution; indemnities; and confidentiality of information, and to the extent that any provisions of the Agreement, including this Addendum, would violate any such restrictions, the Customer will not be bound by such provisions. Any terms or provisions of this Addendum that are less restrictive than those in the Agreement with respect to Customer’s obligations will be null and void and will have no force or effect if the representation and warranty that Customer is a governmental entity is not true or to the extent that the more restrictive term in the Agreement

would be enforceable against Customer under Applicable Laws (as defined below). Terms and conditions in the Agreement relating to limitations of the type described in this section will only be binding on Customer to the extent they are valid and enforceable under all applicable laws, including all state and federal laws, rules and regulations, the constitutions of the United States and the State of Texas and the laws of the United States and the State of Texas (“Applicable Laws”).

3. Maintenance. Except to the extent expressly set forth in a written agreement between the Parties, the Company will not be required to maintain equipment, cable, or other material that is owned by Customer. Customer acknowledges that it is Customer’s sole responsibility to follow the proper administrative or internal procedures to cause its Facilities and any related equipment to be properly maintained. Customer also acknowledges that Company reserves the right, in accordance with Company Tariff, to discontinue service if Customer has failed, or the Company has determined, in its sole discretion, that Customer has failed, to maintain the Property and facilities or any related equipment, cable or other material in a manner that causes or could cause a safety hazard to person or property.

4. Installation. Customer understands that all facilities, equipment, cable and other material referred to in the Agreement must comply with all specifications set forth in said Agreement and the Permanent Easement and/or Right to Pull before the Company installs any equipment or provides electrical service. During the installation of any equipment to be installed by the Company under the Agreement, the Company will use every effort to preserve Customer’s landscaping, parking areas, or other facilities. However, any cost that has been quoted to Customer does not include any special replacements or repairs to these items. The Company shall not be responsible for any expenses associated with replacements or repairs to Customer’s property, and Customer hereby waives any claims for such expenses that it has or may have against the Company.

5. INDEMNIFICATION. This indemnity is pursuant to Company’s Tariff located on our website at www.centerpointenergy.com. CUSTOMER ASSUMES THE RISK OF AND SHALL INDEMNIFY COMPANY AGAINST DAMAGES FOR INJURIES OR DEATH TO PERSONS OR LOSS TO CUSTOMER’S PROPERTY, OR TO THE PROPERTY OF COMPANY, WHEN OCCASIONED BY ACTIVITIES OF CUSTOMER OR THIRD PARTIES ON CUSTOMER’S PREMISES, RESULTING FROM THE INSTALLATION, EXISTENCE, REPLACEMENT, OR REPAIR OF COMPANY’S UNDERGROUND FACILITIES, AND AS FURTHER PROVIDED IN THE TERMS OF “LIMITS ON LIABILITY,” SECTION 5.2 OF COMPANY’S TARIFF. NOTWITHSTANDING ANY OF THE ABOVE, THE PROVISIONS REQUIRING A CUSTOMER TO INDEMNIFY, FULLY PROTECT, OR SAVE COMPANY HARMLESS APPLY TO A GOVERNMENTAL ENTITY AS THIS TERM IS DEFINED IN CHAPTER 2251 OF THE TEXAS GOVERNMENT CODE, TO THE EXTENT OTHERWISE CONSISTENT WITH LAW; PROVIDED, HOWEVER, THAT ANY GOVERNMENTAL ENTITY THAT IS RECEIVING SERVICES UNDER THE AGREEMENT MUST TAKE NECESSARY STEPS TO ENSURE THAT THE INDEMNIFICATION REQUIREMENTS OF THIS SECTION DO NOT CREATE A “DEBT” IN VIOLATION OF ARTICLE XI, SECTION 7 OF THE TEXAS CONSTITUTION. SUCH STEPS MAY INCLUDE, BUT ARE NOT NECESSARILY LIMITED TO, A THIRD-PARTY INDEMNIFICATION IN WHICH THE

CONTRACTOR PERFORMING THE WORK FOR THE GOVERNMENTAL ENTITY INDEMNIFIES THE COMPANY OR THE ESTABLISHMENT OF A SINKING FUND. *SEE BROWN V. JEFFERSON COUNTY, 406 S.W.2D 185 (TEX. 1966).*

6. Further Assurances. If at any time after the date of this Addendum any further action is necessary or appropriate to carry out the purposes of this Addendum, Customer shall use all commercially reasonable efforts to take, or cause to be taken, that action.

7. Assignment. Customer shall not assign any part of its rights or delegate any performance under this Addendum, voluntarily or involuntarily, whether by merger, consolidation, dissolution, operation of law, or any other manner, without the Company's prior written consent. Any purported assignment of rights or delegation of performance in violation of this Section 7 is void and of no effect.

8. Modification; Waiver. No amendment of this Addendum will be effective unless it is in writing and signed by the Parties. No waiver of satisfaction of a condition or nonperformance of an obligation under this Addendum will be effective unless it is in writing and signed by the Party granting the waiver, and no such waiver will constitute a waiver of satisfaction of any other condition or nonperformance of any other obligation. To be valid, any document signed by a Party in accordance with this Section 8 must be signed by an officer or other representative of that Party authorized to do so.

In addition, nothing in this Addendum or the Agreement shall be construed as a waiver or relinquishment by the Company of any right that it has or may have hereafter to discontinue service for or on account of default in the performance of Customer's obligations under this Addendum or the Agreement, including payment of any bill owing or to become owing thereafter, or for any other reason or cause stated in the Company's Tariff.

[The remainder of this page has been intentionally left blank.]

The Parties are signing this Addendum as of the Effective Date.

COMPANY:

CENTERPOINT ENERGY HOUSTON
ELECTRIC, LLC

By: 

Name: Liafis A. Ogboye, P. E.

Title: Supervising Engineer

CUSTOMER:

**LAMAR CONSOLIDATED INDEPENDENT
SCHOOL DISTRICT**

By signing this Addendum, the person purporting to sign this Addendum on behalf of Customer is representing and warranting to the Company that the person has the legal authority to bind Customer and has been duly authorized by Customer to sign and deliver this Addendum to the Company.

By: _____

Name: James Steenbergen

Title: Board President

**CONSIDER APPROVAL OF AMENDMENT #5 TO RFQUOTE #18-2016LN THE
HVAC FULL COVERAGE MAINTENANCE AND SERVICE AGREEMENT**

RECOMMENDATION:

The Board of Trustees approve Amendment #5 in the amount of \$38,700 to the RFQuote #18-2016LN full coverage maintenance and service agreement with Texas Air Systems and authorize the Board President to execute the agreement.

IMPACT/RATIONALE:

The current contract with Texas Air Systems did not include full risk coverage for Lindsey Elementary, Bentley Elementary and the preventive maintenance for the new Support Services Maintenance & Operations building. The \$38,700.00 includes full risk for Lindsey Elementary at \$16,600.00 per year, full risk for Bentley Elementary at \$16,600.00 per year and preventive maintenance at the Support Services Maintenance & Operations Building at \$5,500.00 per year. This amendment will add these facilities to the full coverage maintenance contract.

PROGRAM DESCRIPTION:

Upon approval, the Board President will execute the agreement documents and Texas AirSystems will include Bentley Elementary, Lindsey Elementary, and the new maintenance building in the HVAC full coverage maintenance and service agreement. The HVAC full coverage maintenance and service agreement RFQuote #18-2016LN term expires June 30, 2019.

Submitted by: Leslie Haack, Deputy Superintendent of Support Services
 Paul Gutowsky, RTSBA, ATEM, Energy Coordinator
 Aaron F. Morgan, Region IV Education Service Center

Recommended for approval:

Thomas Randle

Dr. Thomas Randle
Superintendent



July 31, 2018

June 31, 2018

Paul Gutowsky
Energy Coordinator
Lamar Consolidated ISD

Reference: Bentley Elementary and Lindsey Elementary
Adding full risk to the HVAC agreement referencing RF Quote 18-2016LN.

Paul,

This price and scope of work pertains to adding full risk to these above-mentioned facilities to the HVAC agreement. This scope of work corresponds with RF Quote 18-2016LN.

Scope of work:

- Supply and replace all HVAC mechanical system components upon failure.
- Supply and replace all BAS control components upon failure.
- Supply and replace all comfort cooling and heating pumps upon failure.
- Supply and replace all exhaust fan systems.

The cost for these services will be \$33,320.00 dollars per year. These services will begin August 1, 2018.

Regards,

Scott Sory

Scott Sory
Operations Manager
Texas AirSystems



July 13, 2018

Paul Gutowsky
Energy Coordinator
Lamar Consolidated ISD

Reference: New Maintenance and Operations Facility

Paul,

The following price and scope is for adding preventative maintenance to this facility during the warranty period.

All PM work and filter replacements will follow the guidelines referencing RF Quote 18-2016LM.

Scope of work:

- Provide and install all return air filters every 90 days or as environmental conditions dictate.
- Provide preventative maintenance labor on all HVAC equipment on site.
- Provide preventative maintenance functions as per manufacture recommendations.
- Quarterly, record systems operational data and send to LG manufacture support team for preventative analysis.

The cost for these services will be 5,500 dollars per year. These services will begin August 1, 2018.

Please let me know if you have any questions.

Regards,

Scott Sory

Scott Sory

Amendment V to RFQuote 18-2016LN

HVAC Full Coverage Maintenance & Service Agreement

August 16, 2018

This Agreement is made between Lamar Consolidated Independent School District, 3911 Avenue I, Rosenberg, Texas 77471; and Texas AirSystems, 12650 Directors Dr., Suite 600, Stafford, Texas 77477.

In this Agreement, the party who is contracting to receive services shall be referred to as “LCISD” and the party who will be providing the services shall be referred to as “TAS”.

Therefore the parties agree to the following:

- LCISD will pay TAS in the amount of Thirty-Eight Thousand, Seven Hundred Dollars (\$38,700) per year for the following:
 - Bentley Elementary – Full Risk \$16,600.00
 - Lindsey Elementary – Full Risk \$16,600.00
 - Maintenance & Operations Facility – PM/Maint. \$5,500.00
- LCISD will pay TAS for the additions, (Three Thousand, Two Hundred Twenty-Five Dollars) \$3,225.00 per month.
- Performance of Scope of Services will correspond with RFQuote 18-2016LN, HVAC Full Coverage Maintenance & Service Agreement Documents.
- Length of the Agreement: August 1, 2018 to June 30, 2019.

Both Parties agree that the complete agreement between us about these services will consist of this RFQuote 18-2016LN, HVAC Full Coverage Maintenance & Service Agreement.

Agreed to:
Lamar Consolidated Independent School District

Agreed to:
Texas AirSystems

By: _____
Authorized Signature

By: _____
Authorized Signature

Authorized Name (print)

Authorized Name (print)

Customer Address:
Lamar Consolidated Independent School District
3911 Avenue
Rosenberg, Texas 77471
(832) 223- 0000

Contractor Address:
Texas AirSystems
12650 Directors Dr., Suite 600
Stafford, Texas 77477
(832) 342-7000

DISCUSSION OF BOARD TRAINING

School board members are required by Texas law and State Board of Education rule to participate in three types of continuing education: an orientation to local district policy and to the laws affecting public education in Texas; an annual team building activity, taken in conjunction with the rest of the board and the superintendent; and a specified number of hours each year in areas of special need. Board members determine needs with their board annually by reviewing the Framework for School Board Development, a document that outlines the tasks an effective board performs in its governing capacity. Continuing education courses that address these needs are available through a variety of sources.

DISCUSSION OF BOARD SELF-ASSESSMENT

Board self-assessment provides a foundation for growth and improvement. An individual trustee's performance is evaluated periodically by the voters at the ballot box, but rarely is the entire board's performance evaluated, unless the board is intentional in making that happen. As school boards focus on their continuous improvement—learning together and applying that learning as a board team—they set the example and course of action for continuous improvement throughout the school system. This means administrators are improving, operations are increasing efficiency, teaching is becoming more effective, and students are learning more in the classroom. Results from board self-assessment can confirm governance team strengths and inform the board of potential areas for improvement. Both the strengths and areas for improvement can help the board set goals for its learning and development. When the board models this type of self-reflection, they establish an environment that encourages and expects introspection, growth, and continuous improvement throughout the system. The board goals are not district goals. They are goals for how the board is going to improve its work, and there needs to be a clear and focused strategy for improvement. That begins with self-assessment, and then it continues with an actionable plan to focus on the board's work on improving student outcomes.

**CONSIDER APPROVAL OF AMENDMENT #4 TO THE INTERLOCAL
COOPERATION CONTRACT WITH THE TEXAS GENERAL LAND OFFICE**

RECOMMENDATION:

That the Board of Trustees approve the interlocal cooperation contract with The Texas General Land Office for the purchase of natural gas and authorize the Board President to execute the agreement documents and interlocal cooperation contract.

IMPACT/RATIONALE:

Lamar CISD currently has 21 natural gas meters located on secondary campuses that qualify for this program. Amendment #4 will add additional meter located at: Fulshear High School Practice Pool, Foster High School Practice Pool, and George Ranch High School Practice Pool. The interlocal cooperation contract allows LCISD to purchase natural gas in greater volume and at a lower cost. All of the funds earned by The Texas General Land Office will be committed to the State's Permanent School Fund supporting public schools.

PROGRAM DESCRIPTION:

Upon approval, the Board President will execute the agreement documents of Amendment #4 to The Texas General Land Office which will include the natural gas meters at the Fulshear High School Practice Pool, Foster High School Practice Pool, and George Ranch High School Practice Pool into this contract.

Submitted by: Leslie Haack, Deputy Superintendent of Support Services
Paul Gutowsky, RTSBA, ATEM, Energy Coordinator
Aaron F. Morgan, Region IV Education Service Center

Recommended for approval:



Dr. Thomas Randle
Superintendent



**INTERLOCAL COOPERATION CONTRACT
GLO CONTRACT NO. 14-262-000-8398
AMENDMENT NO. 4**

STATE OF TEXAS
COUNTY OF TRAVIS

The **Texas General Land Office** (GLO) and **Lamar CISD, Vendor ID #74-6002016** (Receiving Agency), are parties to that certain Interlocal Cooperation Contract No. 14-262-000-8398, entered into effective April 1, 2014 collectively referred to here as Contract.

Now therefore, the parties agree to amend the Contract effective October 1, 2018 as follows:

1. Exhibit B-2, Gas Consumption Per Month in MMbtu, is being deleted in its entirety and replaced with the attached Exhibit B-3, Gas Consumption Per Month in MMbtu.
2. Exhibit A, Meter Numbers is being deleted in its entirety and replaced with the attached Exhibit A, Meter Numbers.
3. The following Section 7.12, Confidentiality, is added to the original Contract as follows:
Confidentiality: The contents of this Contract and any information related to it are confidential, may be excepted from disclosure and may not be released without the authorization of the General Land Office, a ruling from the Office of the Attorney General or an order from a court to do so. Any request for disclosure of the contents of this Contract or any information related to it received by the Receiving Agency must be submitted to the Office of the Attorney General in accordance with Section 552.301 of the Texas Government Code. The General Land Office must be notified of the request in accordance with Section 552.305 of the Texas Government Code.

Except as amended and modified herein, the terms and conditions of the Contract remain in full force and effect.

TEXAS GENERAL LAND OFFICE

LAMAR CISD

Mark A. Havens
Chief Clerk/Deputy Land Commissioner

James Steenberg
Board President

Date of execution: _____

Date of execution: _____

SA _____ Deputy _____

_____ DIV _____ GC _____

**EXHIBIT B-3
MONTHLY GAS CONSUMPTION ELECTION (MGCE)
CONTRACT #14-262-000-8398**

AGENCY: Lamar CISD
FACILITY NAME: See Attached Exhibit A Meter Listing
ADDRESS: See Attached Exhibit A Meter Listing
CONTACT NAME: Paul Gutowsky
CONTACT PHONE NUMBER: 832-223-0255
EMAIL ADDRESS: PGutowsky@lcisd.org

Gas Consumption Per Month in MMBtu

	<u>Fixed</u>	<u>Index</u>	<u>Total</u>
Apr-17	0	1,593	1,593
May-17	0	1,322	1,322
Jun-17	0	723	723
Jul-17	0	543	543
Aug-17	0	792	792
Sep-17	0	1,162	1,162
Oct-17	0	1,579	1,579
Nov-17	0	2,860	2,860
Dec-17	0	3,622	3,622
Jan-18	0	5,457	5,457
Feb-18	0	4,636	4,636
Mar-18	0	3,086	3,086
TOTAL	0	27,375	27,375

	<u>Fixed</u>	<u>Index</u>	<u>Total</u>
Apr-18	0	1,810	1,810
May-18	0	1,322	1,322
Jun-18	0	723	723
Jul-18	0	543	543
Aug-18	0	792	792
Sep-18	0	1,162	1,162
Oct-18	0	2,179	2,179
Nov-18	0	3,610	3,610
Dec-18	0	4,672	4,672
Jan-19	0	6,507	6,507
Feb-19	0	5,236	5,236
Mar-19	0	3,686	3,686
TOTAL	0	32,242	32,242

Receiving Agency: _____

James Steenbergen
 Title: Board President

Effective Date: October 1, 2018

GLO Initials: _____

Rec'd by Semp Initial/Date _____
 Updated GMS Initial Date _____
 Routed to Legal Initial/Date _____
 Posted into DocuShare Initial/Date _____

Form: Monthly Gas Consumption
 Approved by Legal SEMP
 October 14, 2008

**Lamar CISD
Exhibit A Meter Numbers**

No.	Location	Addresss	Account #	Meter #
1	Foster HS	4400 FM 723	4818963	5002807922
2	Foster HS Field House	4400 FM 723	4818973	5002807928
3	Briscoe JH	4300 FM 723	4818954	5002807916
4	Wertheimer MS	4240 FM 723	7593871	5004194711
5	George Ranch HS	8181 FM 762	8406464	5004272780
6	George Ranch HS	8181 FM 762	8406467	5004362172
7	Reading JH	8101 FM 762	8406472	5004272779
8	Ryon MS	7901 FM 762	9782164	5004617947
9	Lamar Consolidated HS	4606 Mustang Ave	4782503	5002772835
10	Lamar Consolidated HS Field	4606 Mustang Ave	4782517	5002772852
11	Lamar JH	4814 Mustang Ave	4782499	5002772831
12	Maintenance	5017 Avenue I	4782481	5002772815
13	Transportation Shop	5017 Avenue I	4782508	5002772839
14	Natatorium	1011 Horace Mann Ave	9711401447986	5007174837
15	Terry HS	5500 Avenue N	4719856	5002717940
16	Natatorium	5021 Airport Ave	4719868	5002717948
17	Navarro MS	4700 Avenue N	4833074	5002687827
18	George JH	4201 Airport Ave	4780341	5002770711
19	George JH Kitchen	4201 Airport Ave	4719879	5002717956
20	Fulshear High School	9302 Bois D Arc Ln	6400590565	5007391728
21	Leaman Junior High	9320 Bois D Arc Ln	6400590613	5007391645
22	George Ranch Practice Pool	8181 FM 762 RD. PP	6401650876-0	TBD
23	Fulshear Practice Pool	9320 Charger Way PP	6401652138-3	TBD
24	Foster Practice Pool	4400 FM 723 RD. PP	6400264242-5	TBD

**CONSIDER APPROVAL OF APPRAISAL CALENDAR
FOR THE 2018-2019 SCHOOL YEAR**

RECOMMENDATION:

That the Board of Trustees approve the appraisal calendar for the 2018-2019 school year as presented.

IMPACT/RATIONALE:

According to Education Code §21.351 and the corresponding administrative code, TAC §150.1003 (d), each school district shall establish a calendar for teacher appraisals during the required days of instruction for students during one school year. The appraisal calendar shall:

1. Exclude observations in the two weeks following the day of completion of the T-TESS orientation in the school years when an orientation is required, as described in §150.1006 of this title; and
2. Indicate a period for end-of-year conferences that ends no later than 15 working days before the last day of instruction for students.

PROGRAM DESCRIPTION:

See attached calendar for appraisal dates. For the 2018-2019 school year, one appraisal calendar is being presented.

Submitted by: Dr. Kathleen Bowen, Chief Human Resources Officer
 Christine Muzik, Director of Staffing & Records Management

Recommended for approval:

Thomas Randle

Dr. Thomas Randle
Superintendent

APPRAISAL CALENDAR

Observations are excluded on highlighted dates.

IMPORTANT DATES

AUGUST 31

TTESS orientation must be complete.
 Note: for late hires orientation must be completed within three weeks of the first date of employment and observations may begin after that.

SEPTEMBER 17

TTESS observations may begin.

SEPTEMBER 24

Complete SLO staff member orientation

OCTOBER 15

Last day for teachers to submit Goal-Setting and Professional Development Plan (GSPDP).

OCTOBER 15

SLO's finalized (teacher submission and administrator approval completed)

JANUARY 7 - FEBRUARY 8

Mid-year conferences

APRIL 16 - MAY 16

End of year conferences (Including SLO)

APRIL 15

Teachers begin submitting GSPDP reflections to the appraiser prior to the end of year conference.

MAY 2

Last day for TTESS observations.

MAY 16

Last day to conduct end of year conferences.

JUNE 6

All appraisal documents must be finalized and submitted.

JUNE 30

All staff appraisals must be completed and submitted.



Month	S	M	T	W	T	F	S
JULY	1	2	3	4	5	6	7
	8	9	10	11	12	13	14
	15	16	17	18	19	20	21
	22	23	24	25	26	27	28
	29	30	31				
AUGUST				1	2	3	4
	5	6	7	8	9	10	11
	12	13	14	15	16	17	18
	19	20	21	22	23	24	25
26	27	28	29	30	31		
SEPTEMBER							1
	2	3	4	5	6	7	8
	9	10	11	12	13	14	15
	16	17	18	19	20	21	22
23	24	25	26	27	28	29	
30							
OCTOBER							1
	2	3	4	5	6	7	8
	9	10	11	12	13	14	15
	16	17	18	19	20	21	22
23	24	25	26	27	28	29	
30							
NOVEMBER					1	2	3
	4	5	6	7	8	9	10
	11	12	13	14	15	16	17
	18	19	20	21	22	23	24
25	26	27	28	29	30		
DECEMBER							1
	2	3	4	5	6	7	8
	9	10	11	12	13	14	15
	16	17	18	19	20	21	22
23	24	25	26	27	28	29	
30	31						
JANUARY							1
	2	3	4	5	6	7	8
	9	10	11	12	13	14	15
	16	17	18	19	20	21	22
23	24	25	26	27	28	29	
30	31						
FEBRUARY							1
	2	3	4	5	6	7	8
	9	10	11	12	13	14	15
	16	17	18	19	20	21	22
23	24	25	26	27	28	29	
30							
MARCH							1
	2	3	4	5	6	7	8
	9	10	11	12	13	14	15
	16	17	18	19	20	21	22
23	24	25	26	27	28	29	
30	31						
APRIL							1
	2	3	4	5	6	7	8
	9	10	11	12	13	14	15
	16	17	18	19	20	21	22
23	24	25	26	27	28	29	
30							
MAY							1
	2	3	4	5	6	7	8
	9	10	11	12	13	14	15
	16	17	18	19	20	21	22
23	24	25	26	27	28	29	
30	31						
JUNE							1
	2	3	4	5	6	7	8
	9	10	11	12	13	14	15
	16	17	18	19	20	21	22
23	24	25	26	27	28	29	
30							

CONSIDER APPROVAL OF NEW APPRAISERS FOR TEACHING STAFF

RECOMMENDATION:

That the Board of Trustees approve the appraiser(s) who have recently become certified or are new to Lamar Consolidated Independent School District (LCISD).

IMPACT/RATIONALE:

Rules adopted by the State Board of Education indicate that the local District Board of Trustees must approve appraisers other than the teacher's supervisor.

PROGRAM DESCRIPTION:

Listed below are staff members who are new to LCISD or have recently become certified as appraisers.

Sherri Henry
Aide Pina

Submitted by: Dr. Kathleen M. Bowen, Chief Human Resources Officer
Courtney Beard, Lead Staffing Specialist

Recommended for approval:

Thomas Randle

Dr. Thomas Randle
Superintendent

**CONSIDER APPROVAL OF INTERACTIVE FLAT PANELS HARDWARE AND
INSTALLATION, ELECTRICAL, AND PROJECT MANAGEMENT**

RECOMMENDATION:

That the Board of Trustees approve the purchase of interactive flat panels (IFP) and installation hardware and services from ProComputing in the amount of \$790,000; electrical work from Urbish Electrical in the amount of \$2,988; and project management services from Go IT Services according to the existing project management agreement estimated at \$13,000.

IMPACT/RATIONALE:

Adolphus, Jackson, and Travis Elementary Schools have 142 interactive whiteboards and projectors that are out of date, out of warranty, and failing. Viable equipment from these campuses will be repurposed in other locations. Additionally, 9 rooms require power outlets to be added or moved to support the new interactive flat panels. Projected IFP costs include a 10% contingency.

PROGRAM DESCRIPTION:

The 2017 bond includes funds for replacing aging interactive whiteboards and projectors throughout the district. The district evaluated pricing and services proposals from four vendors. ProComputing had the lowest price and offers purchasing co-operative pricing through a BuyBoard contract.

Submitted by: Leslie Haack, Deputy Superintendent of Support Services
David Jacobson, Chief Technology Information Officer

Recommended for approval:



Dr. Thomas Randle
Superintendent



ProComputing

P.O. Box 2720
Grapevine, TX 76099
Phone: (214) 634-2450

PROPOSAL: 106229
DOC. TYPE: SQ
DATE: 07/31/2018
SHIP VIA:

REP: NORMA/MIKE

SOLD TO: LAMAR CISD
ACCOUNTS PAYABLE
3911 AVE I
ROSENBERG, TX 77471-3901
PH. (832) 223-0508

SHIP TO: LAMAR - ADOLPHUS ELEMENTARY
IYAD KAYYALI
7910 WINSTON RANCH PKWY
RICHMOND, TX 77406
PH. (832) 223-0173

Account:	100651	Reference:		Terms:	Net 15 Days
Item Number	Description	Quantity	Price	Extended	

54 ActivPanels / 52 75inch & 2 86inch

AP6-75A-4K	ActivPanel 75" 4K with ActivConnect OPS-G - 2 x Pen Vesa Mount & cable pack included. ActivInspire P	52	\$3,449.00	\$179,348.00
APTMEXT5YROSS	ActivPanel Medium size up to 79 - Extension On Site Support 5 years	52	\$70.00	\$3,640.00
AP6-86A-4K	ActivPanel 86" 4K with ActivConnect OPS-G - 4 x Pen Vesa Mount & cable pack included. ActivInspire P	2	\$5,699.00	\$11,398.00
APL5YROSS	ActivPanel Large (size 80"+) - Extension On Site Support 5 Years	2	\$99.00	\$198.00

Mounts

AP70ASW	Adjustable Wall Mount System for use with ActivPanel *	51	\$643.00	\$32,793.00
AP86ASF	Adjustable Wall Mount System with Floor Support for use with ActivPanel *	2	\$878.00	\$1,756.00
APTMS-3	ActivPanel Mobile Stand - For use with current & previous versions of ActivPanel *	1	\$475.00	\$475.00

Cabling for Wall Mounted installations

DL-1H1A1U-WPKT-W	HDMI, audio and USB 2.0 High Speed Wall Plate HDBaseT Extender Set	53	\$339.00	\$17,967.00
13401	15FT USB AB DEVICE USBA TO USBB	53	\$9.00	\$477.00
2529	15ft 28AWG Standard HDMI® Cable w/Ferrite Cores - Black	53	\$13.00	\$689.00
14001	Wall Insert	53	\$2.22	\$117.66
14003	Wall plate, Recessed / Cable feed	53	\$3.00	\$159.00
ENER-7701	Enerlites Blank Wall Plate - Stainless Steel - 1 Gang	53	\$2.00	\$106.00
ENER-7702	Enerlites Blank Wall Plate - Stainless Steel - 2 Gang	106	\$3.00	\$318.00

Installation and Shipping

ABINSTALL	Promethean Certified Wall Mounted-Installation Includes Removal Of Existing Promethean Systems Including Cabling and Hardware for Disposal/Recycling. Installation of Activpanels, Mounts Cabling Warranty Registration. Coordination of receiving new Product at ProComputing Warehouse and delivery to school on installation days.	53	\$399.00	\$21,147.00
PBINSTALL	Promethean Mobile Installation	1	\$189.00	\$189.00
PSHIPPING	Product Shipping	1	\$3,190.00	\$3,190.00
BUYB	BuyBoard (Contract# 563-18) Audio Visual Equipment and Supplies	1	\$0.00	\$0.00

Sub-Total:	\$273,967.66
Tax:	\$0.00
Total:	\$273,967.66

Fax all purchase orders to the fax number (866) 348-1184, send all payments to the address above.

Prices subject to change without notice, In the event any tax or tariffs are imposed upon the import of the products purchased hereunder, the cost of such tariff shall be added to the purchase price accordingly. Prices reflect purchase of all equipment listed on quote.



ProComputing

P.O. Box 2720
Grapevine, TX 76099
Phone: (214) 634-2450

PROPOSAL: 106239
DOC. TYPE: SQ
DATE: 07/31/2018
SHIP VIA:
REP: NORMA/MIKE

SOLD TO: LAMAR CISD
ACCOUNTS PAYABLE
3911 AVE I
ROSENBERG, TX 77471-3901
PH. (832) 223-0508

SHIP TO: JACKSON ELEMENTARY
IYAD KAYYALI
301 THIRD ST
ROSENBERG, TX 77471-1838
PH. (832) 223-1800

Account:	100651	Reference:		Terms:	Net 15 Days
Item Number	Description	Quantity	Price	Extended	

40 ActivPanels / 38 75inch & 2 86inch

AP6-75A-4K	ActivPanel 75" 4K with ActivConnect OPS-G - 2 x Pen Vesa Mount & cable pack included. ActivInspire P	38	\$3,449.00	\$131,062.00
APTMEXT5YROSS	ActivPanel Medium size up to 79 - Extension On Site Support 5 years	38	\$70.00	\$2,660.00
AP6-86A-4K	ActivPanel 86" 4K with ActivConnect OPS-G - 4 x Pen Vesa Mount & cable pack included. ActivInspire P	2	\$5,699.00	\$11,398.00
APL5YROSS	ActivPanel Large (size 80"+) - Extension On Site Support 5 Years	2	\$99.00	\$198.00

Mounts

AP70ASW	Adjustable Wall Mount System for use with ActivPanel *	36	\$643.00	\$23,148.00
AP86ASF	Adjustable Wall Mount System with Floor Support for use with ActivPanel *	1	\$878.00	\$878.00
APTMS-3	For Library Kiva - Second 86inch ActivPanel in Computer lab is Fixed Height ActivPanel Mobile Stand - For use with current & previous versions of ActivPanel * <i>Computer Lab Is using Fixed Wall Mount Included with ActivPanel</i>	2	\$475.00	\$950.00

Cabling for Wall Mounted Classrooms (Not including Computer Lab)

DL-1H1A1U-WPKT-W	HDMI, audio and USB 2.0 High Speed Wall Plate HDBaseT Extender Set	37	\$339.00	\$12,543.00
13401	15FT USB AB DEVICE USBA TO USBB	37	\$9.00	\$333.00
2529	15ft 28AWG Standard HDMI® Cable w/Ferrite Cores - Black	37	\$13.00	\$481.00

Computer Lab Cabling

39702	DECORA WALL PLATE HDMI/USB 2PORT DONGLE F/F WHITE	1	\$34.95	\$34.95
03725	C2G ECORATIVE ONE CUTOUT SINGLE GANG WALL PLATE - WHITE	1	\$2.99	\$2.99
03839	SINGLE GANG WALL BOX WHT	1	\$4.95	\$4.95
3661	6' HDMI M/M	1	\$9.00	\$9.00
28102	Cables to Go USB 2.0 Cable 6FT. AB device Black USBA to USBB	1	\$5.00	\$5.00
PARTS	Raceway for Cabling	1	\$9.00	\$9.00
3993	10' HDMI Cable Male to Male	1	\$10.00	\$10.00
5439	USB 2.0 A to B Cable 10'	1	\$9.00	\$9.00

Fax all purchase orders to the fax number (866) 343-1184 on next page. Prices subject to change without notice. In the event any tax or tariffs are imposed upon the import of the products purchased hereunder, the cost of such tariff shall be added to the purchase price accordingly. Prices reflect purchase of all equipment listed on quote.



ProComputing

P.O. Box 2720
Grapevine, TX 76099
Phone: (214) 634-2450

PROPOSAL: 106239
DOC. TYPE: SQ
DATE: 07/31/2018
SHIP VIA:
REP: NORMA/MIKE

SOLD TO: LAMAR CISD
ACCOUNTS PAYABLE
3911 AVE I
ROSENBERG, TX 77471-3901
PH. (832) 223-0508

SHIP TO: JACKSON ELEMENTARY
IYAD KAYYALI
301 THIRD ST
ROSENBERG, TX 77471-1838
PH. (832) 223-1800

Account:	100651	Reference:		Terms:	Net 15 Days
Item Number	Description	Quantity	Price	Extended	

Installation and Shipping

ABINSTALL	Promethean Certified Wall Mounted-Installation Includes Removal Of Existing Promethean Systems Including Cabling and Hardware for Disposal/Recycling. Installation of Activpanels, Mounts Cabling Warranty Registration. Coordination of receiving new Product at ProComputing Warehouse and delivery to school on installation days	38	\$399.00	\$15,162.00
PBINSTALL	Promethean Mobile Installation	2	\$189.00	\$378.00
PSHIPPING	Product Shipping	1	\$2,440.00	\$2,440.00
BUYB	BuyBoard (Contract# 563-18) Audio Visual Equipment and Supplies	1	\$0.00	\$0.00

Sub-Total:	\$201,715.89
Tax:	\$0.00
Total:	\$201,715.89

Fax all purchase orders to the fax number (866) 348-1184, send all payments to the address above.

Prices subject to change without notice, In the event any tax or tariffs are imposed upon the import of the products purchased hereunder, the cost of such tariff shall be added to the purchase price accordingly. Prices reflect purchase of all equipment listed on quote.



ProComputing

P.O. Box 2720
 Grapevine, TX 76099
 Phone: (214) 634-2450

PROPOSAL: 106244
DOC. TYPE: SQ
DATE: 07/31/2018
SHIP VIA:
REP: NORMA/MIKE

SOLD TO: LAMAR CISD
 ACCOUNTS PAYABLE
 3911 AVE I
 ROSENBERG, TX 77471-3901
 PH. (832) 223-0508

SHIP TO: TRAVIS ELEMENTARY
 IYAD KAYYALI
 2700 AVE K
 ROSENBERG, TX 77471-3743
 PH. (832) 223-2500

Account:	100651	Reference:		Terms:	Net 15 Days
Item Number	Description	Quantity	Price	Extended	

48 ActivPanels / 47 75inch & 1 86inch

AP6-75A-4K	ActivPanel 75" 4K with ActivConnect OPS-G - 2 x Pen Vesa Mount & cable pack included. ActivInspire P	47	\$3,449.00	\$162,103.00
APTMEXT5YROSS	ActivPanel Medium size up to 79 - Extension On Site Support 5 years	47	\$70.00	\$3,290.00
AP6-86A-4K	ActivPanel 86" 4K with ActivConnect OPS-G - 4 x Pen Vesa Mount & cable pack included. ActivInspire P	1	\$5,699.00	\$5,699.00
APL5YROSS	ActivPanel Large (size 80"+) - Extension On Site Support 5 Years	1	\$99.00	\$99.00

Mounts

AP70ASW	Adjustable Wall Mount System for use with ActivPanel *	47	\$643.00	\$30,221.00
APTMS-3	ActivPanel Mobile Stand - For use with current & previous versions of ActivPanel *	1	\$475.00	\$475.00

Extended Cabling Non Portable Wall Mounted Classrooms

DL-1H1A1U-WPKT-W	HDMI, audio and USB 2.0 High Speed Wall Plate HDBaseT Extender Set	40	\$339.00	\$13,560.00
13401	15FT USB AB DEVICE USBA TO USBB	40	\$9.00	\$360.00
2529	15ft 28AWG Standard HDMI® Cable w/Ferrite Cores - Black	40	\$13.00	\$520.00

Portable Pass Through Wall Plated Cabling HDMI/USB

39702	DECORA WALL PLATE HDMI/USB 2PORT DONGLE F/F WHITE	7	\$34.95	\$244.65
03725	C2G ECORATIVE ONE CUTOUT SINGLE GANG WALL PLATE - WHITE	7	\$2.99	\$20.93
3993	10' HDMI Cable Male to Male	7	\$10.00	\$70.00
5439	USB 2.0 A to B Cable 10'	7	\$9.00	\$63.00
3661	6' HDMI M/M	7	\$9.00	\$63.00
28102	Cables to Go USB 2.0 Cable 6FT. AB device Black USBA to USBB	7	\$5.00	\$35.00

Promethean Installation and Shipping

ABINSTALL	Promethean Certified Wall Mounted-Installation Includes Removal Of Existing Promethean Systems Including Cabling and Hardware for Disposal/Recycling. Installation of Activpanels, Mounts Cabling Warranty Registration. Coordination of receiving new Product at ProComputing Warehouse and delivery to school on installation days.	47	\$399.00	\$18,753.00
PBINSTALL	Promethean Mobile Installation	1	\$189.00	\$189.00
PSHIPPING	Product Shipping	1	\$2,900.00	\$2,900.00

Fax all purchase orders to the fax number (866) 343-1184 on next page. Prices subject to change without notice. In the event any tax or tariffs are imposed upon the import of the products purchased hereunder, the cost of such tariff shall be added to the purchase price accordingly. Prices reflect purchase of all equipment listed on quote.



ProComputing

P.O. Box 2720
Grapevine, TX 76099
Phone: (214) 634-2450

PROPOSAL: 106244
DOC. TYPE: SQ
DATE: 07/31/2018
SHIP VIA:
REP: NORMA/MIKE

SOLD TO: LAMAR CISD
ACCOUNTS PAYABLE
3911 AVE I
ROSENBERG, TX 77471-3901
PH. (832) 223-0508

SHIP TO: TRAVIS ELEMENTARY
IYAD KAYYALI
2700 AVE K
ROSENBERG, TX 77471-3743
PH. (832) 223-2500

Account:	100651	Reference:		Terms:	Net 15 Days
Item Number	Description	Quantity	Price	Extended	

Room 102

Item Number	Description	Quantity	Price	Extended	
75UV340C	LG 75IN 3840X1920 UHD 4K TV TAA 2 HDMI DPM WOL 240HZ CRESTRON COMMERCIAL	1	\$2,875.00	\$2,875.00	
CT75E20000U	5 YR Warranty LG TV	1	\$315.00	\$315.00	
12280	Full-Motion TV Wall Mount for 60-100 inch TVs	1	\$99.00	\$99.00	
39710	HDMI PASS THROUGH DECORA STYLE WALL PLATE - WHITE	1	\$24.00	\$24.00	
03725	C2G ECORATIVE ONE CUTOUT SINGLE GANG WALL PLATE - WHITE	1	\$2.99	\$2.99	
2529	15ft 28AWG Standard HDMI® Cable w/Ferrite Cores - Black	2	\$15.00	\$30.00	
PARTS	Raceway for HDMI Cabling	1	\$9.00	\$9.00	
03839	SINGLE GANG WALL BOX WHT	1	\$4.95	\$4.95	
LABOR	Tv Install	1	\$99.00	\$99.00	
BUYB	BuyBoard (Contract# 563-18) Audio Visual Equipment and Supplies	1	\$0.00	\$0.00	

Sub-Total:	\$242,124.52
Tax:	\$0.00
Total:	\$242,124.52

Fax all purchase orders to the fax number (866) 348-1184, send all payments to the address above.

Prices subject to change without notice, In the event any tax or tariffs are imposed upon the import of the products purchased hereunder, the cost of such tariff shall be added to the purchase price accordingly. Prices reflect purchase of all equipment listed on quote.

URBISH ELECTRIC, LLC

Economical and Dependable Service

POST OFFICE BOX 1459 - ROSENBERG, TEXAS 77471-1459

PHONE 281-342-5321 - FAX 281-239-7639

TECL # 26494

July 28, 2018

Lamar CISD
Jackson Elementary

Addition of seven Outlets

Attn: John R. Parrot

Dear Sir,

Our price to add seven additional outlets for the new smartboards will be \$2354.00 dollars. These outlets are located in the following rooms, Library, 122,125,126,127,133,135.

Sincerely,



Walter Urbish

URBISH ELECTRIC, LLC

Economical and Dependable Service

POST OFFICE BOX 1459 - ROSENBERG, TEXAS 77471-1459

PHONE 281-342-5321 - FAX 281-239-7639

TECL # 26494

July 28, 2018

Lamar CISD
Travis Elementary

Addition of two outlets

Attn: Juan Lozano

Dear Sir,

Our price to install the two 110 outlets for room 102 and room 42 will be \$634.00 dollars.

Sincerely,



Walter Urbish

**CONSIDER APPROVAL OF CONTRACTED SERVICES
FOR DISASTER RECOVERY AND BUSINESS CONTINUITY PLANNING**

RECOMMENDATION:

That the Board of Trustees approve SHI Government Solutions for professional services relating to Disaster Recovery and Business Continuity (DR/BC) Planning in the amount of \$75,000.

IMPACT/RATIONALE:

The district needs a formal disaster recovery and business continuity plan to ensure continuance of operations in the event of systems failure or catastrophic event. The district and operational audit identified this need and it is planned for in Goal 4 of the District Improvement Plan. While informal plans and documentation exist, this project will define the requirements for, develop, and implement a full plan.

The plan will include the following components:

- Technology Recovery Plan
- Operational/Business Recovery Plan
- Emergency Plan/Incident Management Plan
- Site Recovery Plan
- Crisis Management and Communication Plan

PROGRAM DESCRIPTION:

District staff met with four vendors to provide DR/BC planning services. Quotes and Statements of Work were requested from three vendors and two of those submitted acceptable proposals. SHI was 55% less expensive than the other proposal. Pricing is offered through a TIPS contract and will be paid out of local funds.

Submitted by: Leslie Haack, Deputy Superintendent of Support Services
 David Jacobson, Chief Technology Information Officer
 Jason Bright, Director of Network Services

Recommended for approval:

Thomas Randle

Dr. Thomas Randle
Superintendent



Pricing Proposal
 Quotation #: 15306274
 Created On: 5/8/2018
 Valid Until: 8/31/2018

LAMAR CONSOLIDATED INDEPENDENT SCHOOL DISTRICT

Account Executive

Jason Bright
 29826 SM 1093
 Fulshear, TX 77441
 United States
 Phone: (832) 223-0215
 Fax:
 Email: jbright@lcsd.org

Leocadia O'Brien
 1301 S. Mopac Expressway
 Austin, Texas 78745
 Phone: 512-770-4367
 Fax:
 Email: Leocadia_OBrien@shi.com

All Prices are in US Dollar (USD)

Product	Qty	Your Price	Total
1 DR Preparedness Review and Business Continuity Plan Questys Solutions - Part#: NPN-QUESTS-DR Contract Name: TIPS - Technology Solutions, Products and Services Contract #: 170306	1	\$75,000.00	\$75,000.00
		Subtotal	\$75,000.00
		Shipping	\$0.00
		Total	\$75,000.00

Additional Comments

Quest has a no returns policy.

Thank you for choosing SHI-GS! To ensure the best level of service, please provide End User Name, Phone Number, Email Address and applicable Contract Number when submitting a Purchase Order. For any additional information including Hardware, Software and Services Contracts, please contact an SHI-GS Inside Sales Representative at (800) 870-6079.

SHI Government Solutions, Inc. is 100% Minority Owned, Woman Owned Business.
 TAX ID# 22-3695478; DUNS# 14-724-3096

The Products offered under this proposal are resold in accordance with the [SHI Online Customer Resale Terms and Conditions](#), unless a separate resale agreement exists between SHI and the Customer.

**INFORMATION ITEM: STATE OF TEXAS ASSESSMENTS OF ACADEMIC READINESS
(STAAR) RESULTS -- SPRING 2018**

The below tables represent the preliminary results for all students tested and do not represent the final STAAR results used for accountability. STAAR results disaggregated by student groups are provided in this report for the district and individual campuses. Any student group designated with a '--' has less than ten students and is not evaluated as an indicator.

Starting in 2017, students taking the STAAR are scored based on four different performance levels:

- **MASTERS GRADE LEVEL:** Performance in this category indicates that students are expected to succeed in the next grade or course with little or no academic intervention. Students in this category demonstrate the ability to think critically and apply the assessed knowledge and skills in varied contexts, both familiar and unfamiliar. *This is the former label 'Level III: Advanced'.*
- **MEETS GRADE LEVEL:** Performance in this category indicates that students have a high likelihood of success in the next grade or course but may still need some short-term, targeted academic intervention. Students in this category generally demonstrate the ability to think critically and apply the assessed knowledge and skills in familiar contexts. *This is the former label 'Final Level II: Postsecondary Readiness'.*
- **APPROACHES GRADE LEVEL:** Performance in this category indicates that students are likely to succeed in the next grade or course with targeted academic intervention. Students in this category generally demonstrate the ability to apply the assessed knowledge and skills in familiar contexts. *This indicates the student passed the test at the former 'Level II' standard and only requires minor intervention in the next grade level but will not need to be retained nor retested.*
- **DID NOT MEET GRADE LEVEL:** Performance in this category indicates that students are unlikely to succeed in the next grade or course without significant, ongoing academic intervention. Students in this category do not demonstrate a sufficient understanding of the assessed knowledge and skills. *This indicates that the student failed and will need to either retest (Grades 5, 8 Math and Reading and all EOCs), be retained, or will require significant intervention before the next grade level.*

This report reflects students performing at each of the above performance levels, whereas Approaches Grade Level is considered passing, Meets Grade Level is considered as prepared for post-secondary pursuits, and Masters Grade Level is considered as what used to be termed as 'commended performance'. Please note that students that score at Masters Grade Level are also counted as having scored at Approaches and Meets Grade Level. Similarly, students that score at Meets Grade Level are also counted as having scored at Approaches Grade Level, but not necessarily at Masters Grade Level.

Section I – 2018 LCISD Estimated Results by Subject Area:

	Mathematics				Reading/ELA				Writing				Science				Social Studies			
	Total	Appr GL	Meets GL	Master GL	Total	Appr GL	Meets GL	Master GL	Total	Appr GL	Meets GL	Master GL	Total	Appr GL	Meets GL	Master GL	Total	Appr GL	Meets GL	Master GL
All Students	16696	87%	60%	32%	19718	80%	55%	26%	4867	72%	49%	18%	7355	86%	60%	30%	4507	83%	61%	38%
Economic Disadvantage	8079	80%	47%	20%	9321	70%	39%	15%	2333	58%	32%	8%	3438	77%	44%	17%	1988	73%	45%	24%
American Indian/Alaskan Native	40	90%	68%	28%	49	76%	51%	22%	13	85%	46%	23%	19	84%	53%	26%	14	71%	71%	29%
Asian	1113	96%	83%	59%	1332	93%	77%	45%	353	88%	76%	34%	482	94%	80%	54%	320	95%	82%	63%
Black/African American	3297	83%	53%	24%	3936	75%	49%	21%	954	70%	45%	13%	1503	81%	54%	23%	949	82%	56%	32%
Hispanic	7383	83%	51%	24%	8620	73%	44%	17%	2105	63%	36%	10%	3222	81%	48%	19%	1886	76%	49%	27%
Native Hawaiian/Pacific Islander	22	95%	64%	27%	24	84%	48%	20%	--	--	--	--	--	--	--	--	--	--	--	--
Two or More Races	410	92%	69%	35%	476	89%	67%	37%	126	79%	54%	23%	165	94%	70%	41%	96	90%	70%	43%
White	4430	93%	75%	45%	5281	90%	71%	39%	1309	83%	65%	28%	1957	94%	79%	45%	1239	93%	79%	54%
LEP	1992	77%	43%	18%	2166	58%	25%	9%	644	48%	22%	2%	678	66%	24%	7%	251	47%	17%	6%
Special Ed Indicator	1519	49%	19%	7%	1702	35%	14%	5%	451	26%	10%	2%	589	41%	16%	5%	357	39%	17%	6%

Section II – 2016-2018 State versus District Results by Grade Level for STAAR and STAAR-EOC:

State vs. LCISD Comparison of STAAR 3-8 Preliminary Results 2016 to 2018 Students at Approaches GL or Higher							
Grade	STAAR Test	2016 State	2016 LCISD	2017 State	2017 LCISD	2018 State	2018 LCISD
3	Reading	74%	82%	72%	80%	76%	84%
	Math	76%	88%	76%	84%	77%	87%
4	Reading	77%	85%	70%	79%	71%	79%
	Math	74%	85%	75%	87%	77%	86%
	Writing	69%	75%	63%	71%	61%	68%
5	Reading	75%	86%	81%	87%	82%	91%
	Math	79%	92%	87%	94%	90%	95%
	Science	75%	81%	73%	81%	75%	85%
6	Reading	71%	82%	67%	78%	66%	78%
	Math	74%	85%	75%	87%	76%	85%
7	Reading	72%	81%	72%	80%	72%	80%
	Math	71%	78%	68%	71%	71%	72%
	Writing	70%	79%	68%	77%	67%	77%
8	Reading	82%	88%	85%	88%	83%	87%
	Math	73%	90%	84%	91%	84%	88%
	Science	76%	87%	74%	82%	74%	81%
	Social Studies	65%	80%	62%	72%	64%	74%

State vs. LCISD Comparison of STAAR EOC Preliminary Results 2016 to 2018 Students at Approaches GL or Higher						
STAAR EOC	2016 State	2016 LCISD	2017 State	2017 LCISD	2018 State	2018 LCISD
English I	68%	67%	60%	69%	60%	68%
English II	72%	73%	62%	74%	66%	74%
Algebra I	82%	78%	82%	87%	83%	89%
Biology	89%	91%	85%	90%	87%	90%
US History	92%	95%	92%	92%	92%	94%

Section III – 2018 LCISD Estimated Results for Elementary Campuses:

	Mathematics				Reading/ELA				Writing				Science			
	Total	Appr GL	Meets GL	Master GL	Total	Appr GL	Meets GL	Master GL	Total	Appr GL	Meets GL	Master GL	Total	Appr GL	Meets GL	Master GL
Adolphus Elementary	388	95%	76%	46%	388	93%	69%	44%	120	90%	71%	29%	133	86%	56%	22%
Economic Disadvantage	84	92%	64%	32%	84	87%	50%	26%	20	75%	50%	25%	36	75%	39%	11%
Asian	40	90%	75%	60%	40	90%	78%	48%	12	83%	83%	50%	12	83%	83%	42%
Black/African American	80	91%	63%	40%	80	93%	61%	33%	25	92%	68%	32%	31	71%	35%	10%
Hispanic	90	93%	74%	34%	90	90%	60%	34%	25	80%	56%	20%	33	94%	45%	18%
Two or More Races	18	100%	67%	44%	18	89%	78%	50%	--	--	--	--	--	--	--	--
White	156	98%	85%	53%	156	95%	76%	54%	54	94%	78%	28%	48	88%	63%	23%
LEP	29	86%	62%	28%	29	76%	34%	10%	--	--	--	--	--	--	--	--
Special Ed Indicator	32	75%	44%	22%	32	66%	44%	28%	--	--	--	--	11	55%	9%	0%

	Mathematics				Reading/ELA				Writing				Science			
	Total	Appr GL	Meets GL	Master GL	Total	Appr GL	Meets GL	Master GL	Total	Appr GL	Meets GL	Master GL	Total	Appr GL	Meets GL	Master GL
Arredondo Elementary	384	80%	49%	26%	384	73%	43%	21%	137	54%	30%	5%	126	71%	37%	13%
Economic Disadvantage	217	73%	41%	18%	216	66%	31%	12%	69	41%	17%	0%	81	62%	25%	7%
Asian	41	93%	71%	51%	41	93%	63%	41%	19	74%	68%	16%	10	90%	60%	40%
Black/African American	109	73%	41%	24%	110	68%	38%	20%	35	51%	23%	3%	37	62%	32%	8%
Hispanic	147	79%	46%	18%	147	69%	38%	15%	49	49%	29%	4%	56	70%	30%	9%
Two or More Races	10	90%	50%	40%	10	80%	40%	30%	--	--	--	--	--	--	--	--
White	76	83%	57%	29%	75	79%	49%	20%	31	52%	13%	3%	19	79%	58%	26%
LEP	51	86%	49%	24%	51	71%	27%	12%	22	55%	36%	0%	16	75%	19%	0%
Special Ed Indicator	54	41%	15%	6%	53	34%	9%	4%	19	21%	0%	0%	19	32%	11%	0%

	Mathematics				Reading/ELA				Writing				Science			
	Total	Appr GL	Meets GL	Master GL	Total	Appr GL	Meets GL	Master GL	Total	Appr GL	Meets GL	Master GL	Total	Appr GL	Meets GL	Master GL
Austin Elementary	314	95%	73%	47%	313	94%	64%	41%	103	81%	65%	24%	98	95%	66%	42%
Economic Disadvantage	106	91%	65%	38%	106	89%	57%	34%	33	64%	48%	15%	35	91%	60%	34%
Black/African American	37	92%	59%	35%	37	95%	51%	30%	11	91%	82%	27%	10	90%	70%	30%
Hispanic	100	97%	71%	40%	100	93%	61%	37%	32	78%	59%	19%	37	97%	57%	32%
Two or More Races	11	100%	82%	55%	11	100%	91%	55%	--	--	--	--	--	--	--	--
White	152	94%	76%	51%	151	93%	69%	44%	54	78%	61%	24%	44	93%	80%	55%
Special Ed Indicator	22	50%	36%	14%	21	62%	33%	10%	--	--	--	--	--	--	--	--

	Mathematics				Reading/ELA				Writing				Science			
	Total	Appr GL	Meets GL	Master GL	Total	Appr GL	Meets GL	Master GL	Total	Appr GL	Meets GL	Master GL	Total	Appr GL	Meets GL	Master GL
Beasley Elementary	175	86%	50%	26%	175	75%	38%	17%	57	37%	21%	4%	68	84%	35%	16%
Economic Disadvantage	154	85%	47%	23%	154	72%	34%	14%	49	35%	18%	2%	57	81%	32%	12%
Black/African American	22	77%	41%	18%	22	64%	41%	18%	--	--	--	--	10	90%	40%	20%
Hispanic	123	88%	52%	26%	123	76%	35%	15%	36	42%	19%	0%	50	82%	34%	16%
White	23	87%	48%	26%	23	74%	48%	22%	10	40%	30%	10%	--	--	--	--
LEP	65	88%	51%	31%	65	66%	29%	9%	22	41%	27%	0%	21	81%	19%	5%
Special Ed Indicator	21	52%	10%	5%	21	52%	10%	5%	10	0%	0%	0%	--	--	--	--

	Mathematics				Reading/ELA				Writing				Science			
	Total	Appr GL	Meets GL	Master GL	Total	Appr GL	Meets GL	Master GL	Total	Appr GL	Meets GL	Master GL	Total	Appr GL	Meets GL	Master GL
Bentley Elementary	285	95%	73%	41%	285	90%	71%	44%	88	76%	49%	13%	104	93%	62%	33%
Economic Disadvantage	56	95%	68%	36%	56	86%	54%	34%	12	50%	33%	8%	24	92%	54%	29%
Asian	31	100%	81%	71%	31	97%	81%	55%	10	80%	70%	20%	10	100%	90%	50%
Black/African American	58	88%	64%	26%	58	86%	67%	40%	14	79%	43%	0%	24	83%	29%	21%
Hispanic	75	97%	75%	36%	75	89%	71%	41%	19	68%	42%	11%	31	90%	71%	32%
White	113	96%	75%	44%	113	92%	71%	43%	41	78%	54%	17%	36	100%	67%	39%
LEP	25	92%	68%	24%	25	76%	44%	12%	--	--	--	--	--	--	--	--
Special Ed Indicator	28	79%	32%	7%	28	61%	32%	14%	12	33%	8%	0%	12	92%	8%	8%

	Mathematics				Reading/ELA				Writing				Science			
	Total	Appr GL	Meets GL	Master GL	Total	Appr GL	Meets GL	Master GL	Total	Appr GL	Meets GL	Master GL	Total	Appr GL	Meets GL	Master GL
Bowie Elementary	321	73%	35%	12%	321	68%	31%	14%	109	50%	20%	4%	99	72%	28%	11%
Economic Disadvantage	278	71%	33%	11%	278	66%	29%	11%	90	49%	19%	1%	87	69%	28%	11%
Black/African American	19	58%	21%	5%	19	58%	16%	16%	--	--	--	--	--	--	--	--
Hispanic	274	74%	34%	12%	274	68%	31%	14%	92	51%	23%	4%	85	72%	26%	9%
White	25	64%	40%	12%	25	72%	40%	8%	--	--	--	--	--	--	--	--
LEP	115	76%	37%	13%	114	72%	25%	13%	37	54%	27%	3%	35	66%	11%	0%
Special Ed Indicator	54	31%	11%	2%	54	30%	13%	0%	19	16%	0%	0%	17	53%	12%	0%

	Mathematics				Reading/ELA				Writing				Science			
	Total	Appr GL	Meets GL	Master GL	Total	Appr GL	Meets GL	Master GL	Total	Appr GL	Meets GL	Master GL	Total	Appr GL	Meets GL	Master GL
Campbell Elementary	328	98%	91%	68%	328	97%	86%	58%	105	95%	79%	36%	120	97%	81%	48%
Economic Disadvantage	18	94%	83%	56%	18	89%	83%	28%	--	--	--	--	--	--	--	--
Asian	25	100%	100%	84%	25	100%	100%	68%	12	100%	83%	50%	--	--	--	--
Black/African American	22	86%	82%	55%	22	82%	77%	36%	10	70%	40%	0%	--	--	--	--
Hispanic	52	98%	87%	67%	52	94%	83%	54%	17	100%	82%	47%	18	94%	89%	61%
White	225	99%	91%	67%	225	98%	86%	60%	66	97%	83%	36%	84	98%	81%	43%
Special Ed Indicator	23	83%	57%	35%	23	65%	48%	39%	11	82%	45%	27%	--	--	--	--

	Mathematics				Reading/ELA				Writing				Science			
	Total	Appr GL	Meets GL	Master GL	Total	Appr GL	Meets GL	Master GL	Total	Appr GL	Meets GL	Master GL	Total	Appr GL	Meets GL	Master GL
Dickinson Elementary	296	97%	82%	57%	297	95%	81%	59%	98	88%	68%	39%	107	95%	77%	38%
Economic Disadvantage	28	86%	57%	29%	28	82%	61%	54%	14	64%	50%	7%	--	--	--	--
Asian	33	97%	88%	73%	33	97%	85%	52%	11	91%	82%	45%	--	--	--	--
Black/African American	21	100%	67%	38%	21	95%	62%	43%	11	82%	64%	45%	--	--	--	--
Hispanic	53	94%	74%	49%	54	89%	72%	52%	19	89%	63%	42%	20	90%	75%	15%
Two or More Races	10	100%	80%	50%	10	100%	80%	70%	--	--	--	--	--	--	--	--
White	178	97%	86%	60%	178	96%	85%	64%	53	89%	70%	36%	71	99%	77%	44%
Special Ed Indicator	23	78%	30%	13%	24	63%	42%	25%	--	--	--	--	--	--	--	--

	Mathematics				Reading/ELA				Writing				Science			
	Total	Appr GL	Meets GL	Master GL	Total	Appr GL	Meets GL	Master GL	Total	Appr GL	Meets GL	Master GL	Total	Appr GL	Meets GL	Master GL
Frost Elementary	278	98%	86%	56%	277	97%	82%	59%	89	89%	62%	20%	94	94%	83%	47%
Economic Disadvantage	48	92%	73%	50%	47	94%	66%	38%	25	92%	64%	8%	12	75%	58%	17%
Black/African American	23	87%	70%	22%	23	91%	61%	39%	--	--	--	--	--	--	--	--
Hispanic	58	97%	78%	45%	57	96%	65%	47%	28	100%	64%	11%	14	93%	64%	36%
White	182	99%	89%	64%	182	99%	90%	65%	48	85%	60%	31%	67	96%	91%	51%
Special Ed Indicator	29	86%	48%	28%	29	83%	55%	21%	11	64%	36%	0%	14	64%	43%	0%

	Mathematics				Reading/ELA				Writing				Science			
	Total	Appr GL	Meets GL	Master GL	Total	Appr GL	Meets GL	Master GL	Total	Appr GL	Meets GL	Master GL	Total	Appr GL	Meets GL	Master GL
Hubenak Elementary	372	98%	80%	56%	372	97%	73%	46%	110	80%	57%	19%	129	93%	74%	44%
Economic Disadvantage	100	99%	76%	48%	100	96%	62%	33%	25	68%	44%	8%	39	87%	59%	36%
Asian	52	100%	92%	79%	52	98%	90%	71%	13	92%	85%	62%	22	91%	77%	59%
Black/African American	99	98%	71%	46%	99	97%	67%	41%	30	77%	60%	7%	31	84%	65%	42%
Hispanic	101	97%	81%	57%	101	97%	71%	39%	34	82%	50%	21%	34	94%	71%	32%
Two or More Races	17	100%	82%	53%	17	100%	71%	47%	--	--	--	--	--	--	--	--
White	100	97%	82%	54%	100	96%	73%	46%	28	75%	46%	4%	38	100%	82%	47%
LEP	34	94%	68%	44%	34	94%	62%	18%	10	70%	20%	0%	--	--	--	--
Special Ed Indicator	22	91%	59%	27%	22	86%	50%	27%	11	45%	18%	9%	--	--	--	--

	Mathematics				Reading/ELA				Writing				Science			
	Total	Appr GL	Meets GL	Master GL	Total	Appr GL	Meets GL	Master GL	Total	Appr GL	Meets GL	Master GL	Total	Appr GL	Meets GL	Master GL
Huggins Elementary	377	92%	68%	40%	376	89%	66%	43%	114	71%	53%	18%	131	92%	66%	31%
Economic Disadvantage	82	73%	34%	16%	82	73%	40%	18%	33	52%	39%	0%	21	67%	24%	0%
Black/African American	37	68%	27%	8%	37	68%	43%	14%	13	46%	31%	8%	--	--	--	--
Hispanic	63	81%	49%	30%	63	78%	52%	37%	24	58%	38%	13%	20	85%	50%	20%
Two or More Races	11	91%	73%	36%	11	100%	73%	64%	--	--	--	--	--	--	--	--
White	263	98%	78%	47%	262	94%	72%	47%	71	79%	62%	20%	98	95%	73%	35%
LEP	20	80%	30%	10%	20	80%	20%	10%	--	--	--	--	--	--	--	--
Special Ed Indicator	36	58%	28%	14%	36	53%	25%	11%	12	17%	0%	0%	--	--	--	--

	Mathematics				Reading/ELA				Writing				Science			
	Total	Appr GL	Meets GL	Master GL	Total	Appr GL	Meets GL	Master GL	Total	Appr GL	Meets GL	Master GL	Total	Appr GL	Meets GL	Master GL
Hutchison Elementary	324	87%	60%	32%	324	81%	53%	29%	100	68%	49%	16%	110	85%	45%	19%
Economic Disadvantage	134	82%	46%	21%	134	74%	43%	19%	44	55%	36%	11%	47	85%	38%	11%
Asian	63	95%	79%	59%	63	89%	62%	40%	22	77%	64%	27%	20	90%	50%	20%
Black/African American	106	85%	58%	28%	106	83%	55%	25%	26	62%	35%	8%	44	91%	50%	25%
Hispanic	78	78%	51%	21%	78	72%	45%	24%	28	64%	46%	21%	22	82%	36%	14%
Two or More Races	21	95%	67%	33%	21	90%	76%	43%	--	--	--	--	--	--	--	--
White	54	89%	52%	26%	54	78%	44%	26%	14	64%	43%	7%	19	68%	37%	11%
LEP	34	82%	38%	24%	34	65%	18%	12%	12	50%	42%	25%	11	55%	18%	0%
Special Ed Indicator	35	49%	17%	3%	35	40%	20%	6%	11	18%	0%	0%	11	45%	9%	0%

	Mathematics				Reading/ELA				Writing				Science			
	Total	Appr GL	Meets GL	Master GL	Total	Appr GL	Meets GL	Master GL	Total	Appr GL	Meets GL	Master GL	Total	Appr GL	Meets GL	Master GL
Jackson Elementary	183	92%	63%	37%	183	85%	51%	20%	63	54%	29%	3%	55	87%	55%	33%
Economic Disadvantage	171	93%	64%	37%	171	85%	50%	18%	61	54%	28%	3%	51	88%	53%	31%
Black/African American	26	88%	27%	19%	26	69%	31%	12%	--	--	--	--	--	--	--	--
Hispanic	152	93%	68%	39%	152	87%	55%	20%	53	55%	28%	4%	46	87%	57%	35%
LEP	94	94%	73%	45%	94	88%	61%	26%	30	63%	30%	7%	30	90%	60%	40%
Special Ed Indicator	16	56%	19%	13%	16	38%	0%	0%	--	--	--	--	--	--	--	--

	Mathematics				Reading/ELA				Writing				Science			
	Total	Appr GL	Meets GL	Master GL	Total	Appr GL	Meets GL	Master GL	Total	Appr GL	Meets GL	Master GL	Total	Appr GL	Meets GL	Master GL
Lindsey Elementary	203	94%	57%	29%	202	90%	59%	32%	65	83%	60%	12%	68	84%	49%	16%
Economic Disadvantage	44	89%	50%	23%	44	82%	55%	18%	15	73%	40%	7%	12	92%	75%	17%
Asian	21	100%	81%	62%	21	100%	57%	43%	--	--	--	--	--	--	--	--
Black/African American	42	95%	57%	29%	42	88%	62%	40%	11	73%	55%	9%	13	85%	77%	23%
Hispanic	56	91%	43%	21%	56	86%	50%	21%	12	83%	58%	25%	22	82%	27%	9%
Two or More Races	12	92%	75%	17%	11	91%	73%	45%	--	--	--	--	--	--	--	--
White	71	94%	58%	27%	71	90%	65%	31%	28	82%	61%	7%	22	77%	45%	18%
LEP	29	86%	41%	14%	29	79%	28%	14%	--	--	--	--	--	--	--	--
Special Ed Indicator	24	79%	29%	4%	24	58%	38%	13%	--	--	--	--	10	30%	10%	10%

	Mathematics				Reading/ELA				Writing				Science			
	Total	Appr GL	Meets GL	Master GL	Total	Appr GL	Meets GL	Master GL	Total	Appr GL	Meets GL	Master GL	Total	Appr GL	Meets GL	Master GL
Long Elementary	250	92%	66%	33%	251	86%	49%	20%	85	60%	35%	11%	82	77%	40%	12%
Economic Disadvantage	204	92%	63%	31%	205	84%	45%	18%	64	53%	27%	8%	67	76%	39%	10%
Black/African American	46	89%	54%	20%	47	81%	40%	17%	15	53%	27%	0%	19	74%	32%	11%
Hispanic	177	93%	69%	37%	177	88%	50%	19%	58	60%	38%	14%	55	78%	45%	15%
White	25	88%	64%	28%	25	80%	56%	28%	10	70%	40%	10%	--	--	--	--
LEP	65	88%	71%	37%	65	78%	46%	15%	23	74%	43%	13%	16	56%	25%	0%
Special Ed Indicator	52	67%	33%	10%	52	56%	21%	2%	17	29%	12%	0%	16	44%	25%	0%

	Mathematics				Reading/ELA				Writing				Science			
	Total	Appr GL	Meets GL	Master GL	Total	Appr GL	Meets GL	Master GL	Total	Appr GL	Meets GL	Master GL	Total	Appr GL	Meets GL	Master GL
McNeill Elementary	401	91%	71%	47%	401	93%	69%	45%	131	82%	61%	15%	151	94%	76%	44%
Economic Disadvantage	159	85%	61%	38%	159	89%	58%	37%	61	79%	54%	11%	50	88%	72%	42%
Asian	75	93%	77%	51%	75	95%	75%	48%	31	87%	68%	26%	21	95%	71%	38%
Black/African American	149	87%	70%	46%	149	91%	66%	42%	40	80%	58%	10%	63	94%	73%	43%
Hispanic	85	93%	68%	48%	85	93%	69%	49%	31	77%	65%	10%	35	91%	86%	46%
Two or More Races	22	91%	82%	55%	22	95%	82%	64%	--	--	--	--	--	--	--	--
White	68	96%	68%	44%	68	96%	66%	41%	21	81%	62%	14%	22	95%	77%	50%
LEP	69	84%	48%	17%	69	90%	52%	22%	36	72%	42%	3%	--	--	--	--
Special Ed Indicator	25	44%	20%	4%	25	56%	20%	0%	11	36%	9%	0%	--	--	--	--

	Mathematics				Reading/ELA				Writing				Science			
	Total	Appr GL	Meets GL	Master GL	Total	Appr GL	Meets GL	Master GL	Total	Appr GL	Meets GL	Master GL	Total	Appr GL	Meets GL	Master GL
Meyer Elementary	359	82%	51%	27%	359	74%	39%	20%	133	53%	26%	5%	108	70%	35%	10%
Economic Disadvantage	252	78%	43%	24%	252	70%	34%	16%	91	46%	19%	2%	77	64%	29%	8%
Black/African American	75	83%	43%	24%	75	77%	41%	20%	31	52%	26%	10%	21	76%	29%	10%
Hispanic	222	82%	51%	27%	222	71%	37%	19%	80	53%	23%	3%	71	65%	34%	10%
White	47	81%	64%	32%	47	79%	45%	26%	15	60%	40%	13%	13	92%	54%	15%
LEP	55	82%	44%	24%	55	73%	25%	9%	29	55%	10%	3%	15	60%	13%	0%
Special Ed Indicator	31	29%	13%	6%	31	26%	10%	6%	10	20%	10%	0%	--	--	--	--

	Mathematics				Reading/ELA				Writing				Science			
	Total	Appr GL	Meets GL	Master GL	Total	Appr GL	Meets GL	Master GL	Total	Appr GL	Meets GL	Master GL	Total	Appr GL	Meets GL	Master GL
Pink Elementary	318	80%	42%	17%	317	64%	25%	10%	115	35%	17%	0%	100	61%	18%	4%
Economic Disadvantage	304	80%	42%	17%	303	63%	24%	9%	110	33%	16%	0%	95	60%	18%	4%
Black/African American	50	66%	30%	12%	49	59%	20%	4%	14	29%	14%	0%	18	44%	11%	0%
Hispanic	254	82%	43%	18%	254	66%	25%	10%	97	35%	16%	0%	79	65%	18%	5%
White	11	73%	45%	18%	11	55%	27%	27%	--	--	--	--	--	--	--	--
LEP	129	83%	45%	18%	129	68%	28%	12%	57	35%	19%	0%	33	64%	18%	6%
Special Ed Indicator	42	50%	17%	2%	41	22%	7%	2%	15	0%	0%	0%	11	27%	0%	0%

	Mathematics				Reading/ELA				Writing				Science			
	Total	Appr GL	Meets GL	Master GL	Total	Appr GL	Meets GL	Master GL	Total	Appr GL	Meets GL	Master GL	Total	Appr GL	Meets GL	Master GL
Ray Elementary	324	95%	69%	30%	323	91%	50%	17%	109	83%	50%	13%	109	92%	36%	12%
Economic Disadvantage	287	95%	68%	29%	286	90%	49%	16%	95	83%	46%	12%	96	92%	33%	11%
Black/African American	18	83%	56%	22%	18	83%	61%	17%	--	--	--	--	--	--	--	--
Hispanic	286	95%	69%	29%	285	91%	47%	16%	95	82%	48%	13%	97	92%	35%	11%
White	16	100%	75%	44%	16	100%	75%	38%	--	--	--	--	--	--	--	--
LEP	120	92%	71%	24%	119	92%	47%	16%	35	86%	37%	6%	41	95%	29%	10%
Special Ed Indicator	21	76%	43%	14%	20	75%	35%	0%	--	--	--	--	--	--	--	--

	Mathematics				Reading/ELA				Writing				Science			
	Total	Appr GL	Meets GL	Master GL	Total	Appr GL	Meets GL	Master GL	Total	Appr GL	Meets GL	Master GL	Total	Appr GL	Meets GL	Master GL
Smith Elementary	188	81%	51%	24%	188	74%	40%	15%	67	54%	30%	1%	62	79%	39%	10%
Economic Disadvantage	168	80%	51%	26%	168	73%	40%	16%	60	53%	30%	2%	55	80%	36%	9%
Black/African American	32	72%	41%	28%	32	69%	44%	22%	13	38%	38%	0%	--	--	--	--
Hispanic	131	83%	53%	24%	131	74%	40%	13%	44	57%	30%	0%	49	78%	39%	8%
White	19	89%	53%	16%	19	79%	37%	16%	--	--	--	--	--	--	--	--
LEP	72	90%	64%	35%	72	75%	46%	18%	25	60%	44%	0%	25	80%	40%	12%
Special Ed Indicator	17	47%	0%	0%	17	41%	12%	0%	10	0%	0%	0%	--	--	--	--

	Mathematics				Reading/ELA				Writing				Science			
	Total	Appr GL	Meets GL	Master GL	Total	Appr GL	Meets GL	Master GL	Total	Appr GL	Meets GL	Master GL	Total	Appr GL	Meets GL	Master GL
Thomas Elementary	400	89%	62%	37%	400	81%	48%	23%	127	57%	29%	7%	124	77%	35%	14%
Economic Disadvantage	192	84%	51%	22%	192	75%	39%	15%	66	45%	15%	2%	59	69%	25%	8%
Asian	28	96%	86%	64%	28	93%	79%	46%	--	--	--	--	--	--	--	--
Black/African American	113	81%	47%	19%	113	70%	35%	16%	38	53%	34%	3%	36	69%	33%	8%
Hispanic	179	91%	65%	37%	179	82%	47%	20%	58	53%	16%	2%	61	75%	26%	11%
Two or More Races	11	91%	82%	82%	11	91%	64%	36%	--	--	--	--	--	--	--	--
White	67	91%	69%	48%	67	90%	57%	30%	17	59%	29%	18%	17	94%	59%	24%
LEP	48	94%	56%	25%	48	71%	25%	4%	13	38%	15%	0%	18	61%	22%	0%
Special Ed Indicator	37	35%	16%	5%	37	32%	8%	3%	14	14%	7%	0%	--	--	--	--

	Mathematics				Reading/ELA				Writing				Science			
	Total	Appr GL	Meets GL	Master GL	Total	Appr GL	Meets GL	Master GL	Total	Appr GL	Meets GL	Master GL	Total	Appr GL	Meets GL	Master GL
Travis Elementary	285	78%	42%	22%	285	68%	34%	16%	98	42%	16%	1%	108	63%	25%	10%
Economic Disadvantage	245	77%	40%	21%	245	67%	33%	15%	84	39%	13%	1%	93	62%	24%	10%
Black/African American	22	64%	23%	9%	22	36%	23%	5%	11	36%	18%	9%	--	--	--	--
Hispanic	238	78%	41%	21%	238	69%	34%	16%	81	43%	16%	0%	92	61%	21%	7%
White	22	91%	59%	59%	22	91%	50%	36%	--	--	--	--	--	--	--	--
LEP	77	88%	52%	26%	77	79%	48%	19%	22	55%	14%	0%	32	75%	31%	13%
Special Ed Indicator	35	43%	9%	3%	35	37%	3%	0%	12	8%	8%	0%	13	15%	8%	0%

	Mathematics				Reading/ELA				Writing				Science			
	Total	Appr GL	Meets GL	Master GL	Total	Appr GL	Meets GL	Master GL	Total	Appr GL	Meets GL	Master GL	Total	Appr GL	Meets GL	Master GL
Velasquez Elementary	313	81%	50%	23%	312	79%	51%	26%	100	55%	29%	7%	93	88%	48%	23%
Economic Disadvantage	172	74%	35%	15%	171	70%	36%	12%	57	46%	21%	5%	52	79%	38%	19%
Black/African American	69	77%	51%	17%	69	72%	41%	22%	29	52%	24%	0%	16	88%	50%	19%
Hispanic	119	80%	39%	17%	119	73%	46%	20%	30	47%	17%	7%	44	86%	36%	23%
Two or More Races	14	86%	50%	21%	14	100%	50%	36%	--	--	--	--	--	--	--	--
White	102	84%	61%	33%	101	87%	63%	35%	34	65%	41%	15%	25	92%	64%	20%
LEP	24	79%	50%	8%	23	78%	26%	9%	--	--	--	--	--	--	--	--
Special Ed Indicator	31	35%	13%	6%	31	48%	16%	3%	14	21%	0%	0%	--	--	--	--

	Mathematics				Reading/ELA				Writing				Science			
	Total	Appr GL	Meets GL	Master GL	Total	Appr GL	Meets GL	Master GL	Total	Appr GL	Meets GL	Master GL	Total	Appr GL	Meets GL	Master GL
Williams Elementary	467	97%	70%	42%	467	92%	64%	39%	160	83%	58%	14%	169	91%	59%	27%
Economic Disadvantage	158	94%	63%	35%	159	87%	51%	27%	59	78%	46%	10%	57	82%	53%	14%
Asian	72	99%	89%	61%	72	94%	85%	60%	27	96%	89%	30%	23	96%	91%	39%
Black/African American	151	95%	60%	32%	152	91%	55%	32%	49	76%	53%	14%	58	88%	48%	17%
Hispanic	120	95%	64%	35%	119	88%	51%	29%	40	78%	40%	3%	48	90%	50%	27%
Two or More Races	13	100%	54%	38%	13	85%	69%	46%	--	--	--	--	--	--	--	--
White	110	98%	77%	49%	110	96%	75%	46%	41	90%	63%	15%	34	94%	71%	38%
LEP	49	90%	51%	22%	49	73%	43%	16%	21	67%	38%	0%	13	77%	46%	8%
Special Ed Indicator	21	76%	38%	14%	22	64%	23%	9%	--	--	--	--	10	60%	20%	10%

Section IV – 2018 LCISD Estimated Results for Middle School and Junior High Campuses:

	Mathematics				Reading/ELA			
	Total	Appr GL	Meets GL	Master GL	Total	Appr GL	Meets GL	Master GL
Navarro Middle	535	76%	42%	15%	537	68%	34%	14%
Economic Disadvantage	412	73%	39%	13%	413	65%	29%	11%
Black/African American	85	86%	40%	7%	85	72%	36%	13%
Hispanic	387	74%	43%	16%	388	67%	32%	14%
White	49	78%	37%	12%	50	64%	34%	20%
LEP	83	52%	23%	5%	83	46%	8%	1%
Special Ed Indicator	61	30%	7%	2%	61	20%	5%	3%

	Mathematics				Reading/ELA			
	Total	Appr GL	Meets GL	Master GL	Total	Appr GL	Meets GL	Master GL
Ryon Middle School	678	90%	65%	36%	679	86%	57%	28%
Economic Disadvantage	221	79%	51%	23%	221	76%	43%	18%
Asian	74	99%	80%	53%	74	91%	66%	41%
Black/African American	134	77%	46%	19%	134	81%	49%	21%
Hispanic	215	87%	56%	25%	215	78%	47%	19%
Two or More Races	18	94%	67%	28%	19	100%	58%	26%
White	232	97%	80%	51%	232	92%	68%	38%
LEP	29	90%	31%	7%	29	52%	7%	0%
Special Ed Indicator	52	60%	23%	12%	52	46%	19%	4%

	Mathematics				Reading/ELA			
	Total	Appr GL	Meets GL	Master GL	Total	Appr GL	Meets GL	Master GL
Wertheimer Middle School	415	91%	66%	33%	416	84%	58%	33%
Economic Disadvantage	139	89%	53%	21%	139	79%	50%	22%
Asian	41	100%	80%	46%	41	95%	68%	44%
Black/African American	88	90%	53%	23%	88	77%	57%	24%
Hispanic	144	86%	55%	26%	145	77%	46%	23%
Two or More Races	15	87%	73%	20%	15	80%	67%	40%
White	125	94%	82%	48%	125	93%	69%	47%
LEP	53	81%	32%	11%	53	60%	19%	8%
Special Ed Indicator	24	50%	25%	21%	24	29%	21%	17%

	Mathematics				Reading/ELA			
	Total	Appr GL	Meets GL	Master GL	Total	Appr GL	Meets GL	Master GL
Wessendorff Middle	397	78%	41%	16%	397	67%	34%	16%
Economic Disadvantage	288	74%	35%	12%	288	64%	28%	12%
Asian	13	92%	69%	62%	13	77%	77%	38%
Black/African American	77	75%	31%	13%	77	62%	27%	18%
Hispanic	245	76%	38%	12%	245	67%	34%	14%
White	54	85%	61%	24%	54	70%	37%	20%
LEP	41	41%	10%	5%	41	34%	5%	2%
Special Ed Indicator	34	38%	9%	0%	34	21%	9%	3%

	Mathematics				Reading/ELA				Writing				Science				Social Studies			
	Total	Appr GL	Meets GL	Master GL	Total	Appr GL	Meets GL	Master GL	Total	Appr GL	Meets GL	Master GL	Total	Appr GL	Meets GL	Master GL	Total	Appr GL	Meets GL	Master GL
Briscoe Jr High	873	90%	65%	33%	873	89%	61%	38%	435	87%	64%	30%	438	87%	70%	42%	435	80%	52%	29%
Economic Disadvantage	297	82%	47%	18%	298	81%	45%	25%	143	79%	47%	15%	155	76%	51%	26%	153	65%	36%	19%
Asian	75	96%	84%	56%	75	92%	76%	56%	35	89%	83%	46%	40	95%	85%	68%	39	95%	77%	51%
Black/African American	186	82%	53%	25%	187	84%	56%	32%	97	86%	55%	22%	91	79%	58%	34%	90	74%	44%	23%
Hispanic	296	89%	55%	21%	297	86%	52%	29%	148	84%	56%	18%	147	85%	59%	27%	147	71%	37%	19%
Two or More Races	24	88%	63%	25%	24	92%	67%	42%	12	92%	67%	25%	12	92%	83%	67%	12	92%	67%	42%
White	289	96%	78%	47%	287	93%	70%	46%	141	89%	74%	45%	147	92%	84%	52%	146	88%	64%	36%
LEP	47	66%	23%	4%	47	55%	11%	4%	29	62%	31%	0%	18	44%	28%	11%	18	44%	17%	11%
Special Ed Indicator	46	41%	17%	4%	44	45%	7%	2%	22	41%	5%	0%	24	25%	13%	8%	24	17%	13%	4%

	Mathematics				Reading/ELA				Writing				Science				Social Studies			
	Total	Appr GL	Meets GL	Master GL	Total	Appr GL	Meets GL	Master GL	Total	Appr GL	Meets GL	Master GL	Total	Appr GL	Meets GL	Master GL	Total	Appr GL	Meets GL	Master GL
George Jr High School	1074	67%	32%	10%	1071	71%	36%	18%	548	56%	28%	6%	524	65%	37%	18%	525	51%	20%	10%
Economic Disadvantage	798	65%	29%	8%	795	68%	31%	16%	406	52%	25%	5%	390	62%	33%	15%	391	48%	17%	8%
Asian	12	92%	50%	25%	12	92%	50%	25%	--	--	--	--	--	--	--	--	--	--	--	--
Black/African American	144	63%	32%	10%	144	70%	33%	18%	79	59%	30%	5%	66	62%	33%	14%	66	58%	17%	9%
Hispanic	819	67%	30%	10%	817	71%	34%	17%	409	54%	26%	5%	407	65%	36%	17%	408	49%	20%	9%
Two or More Races	16	69%	44%	0%	16	63%	44%	25%	12	83%	50%	33%	--	--	--	--	--	--	--	--
White	81	66%	39%	16%	80	73%	49%	29%	41	56%	37%	15%	40	70%	53%	38%	40	65%	33%	18%
LEP	140	50%	11%	1%	140	36%	7%	1%	81	19%	1%	0%	57	40%	12%	2%	58	26%	3%	0%
Special Ed Indicator	118	26%	5%	3%	118	21%	6%	2%	63	10%	5%	0%	54	15%	6%	4%	54	6%	0%	0%

	Mathematics				Reading/ELA				Writing				Science				Social Studies			
	Total	Appr GL	Meets GL	Master GL	Total	Appr GL	Meets GL	Master GL	Total	Appr GL	Meets GL	Master GL	Total	Appr GL	Meets GL	Master GL	Total	Appr GL	Meets GL	Master GL
Lamar Jr High School	829	80%	49%	17%	830	76%	44%	24%	416	66%	39%	14%	412	78%	50%	25%	412	67%	36%	22%
Economic Disadvantage	577	75%	42%	11%	578	71%	36%	19%	290	58%	30%	10%	286	73%	41%	16%	286	60%	27%	14%
Asian	42	90%	88%	48%	42	90%	64%	40%	24	79%	63%	25%	18	100%	83%	67%	18	94%	72%	61%
Black/African American	207	73%	43%	8%	207	74%	45%	23%	104	63%	38%	10%	103	74%	46%	19%	103	67%	28%	18%
Hispanic	448	78%	44%	13%	449	72%	36%	20%	214	62%	31%	12%	233	74%	43%	17%	233	60%	32%	18%
Two or More Races	12	100%	50%	8%	12	83%	58%	33%	--	--	--	--	--	--	--	--	--	--	--	--
White	114	91%	65%	36%	114	89%	63%	37%	64	80%	59%	27%	50	96%	76%	52%	50	88%	52%	34%
LEP	105	59%	23%	3%	105	47%	10%	4%	57	23%	4%	2%	47	57%	13%	0%	47	43%	13%	9%
Special Ed Indicator	82	35%	6%	1%	82	22%	2%	1%	42	17%	5%	0%	44	30%	7%	2%	44	16%	2%	2%

	Mathematics				Reading/ELA				Writing				Science				Social Studies			
	Total	Appr GL	Meets GL	Master GL	Total	Appr GL	Meets GL	Master GL	Total	Appr GL	Meets GL	Master GL	Total	Appr GL	Meets GL	Master GL	Total	Appr GL	Meets GL	Master GL
Leaman Junior High	971	92%	71%	36%	970	88%	64%	40%	327	87%	66%	24%	295	92%	64%	35%	293	84%	55%	33%
Economic Disadvantage	203	85%	59%	24%	203	79%	48%	25%	80	78%	49%	20%	59	83%	42%	19%	59	68%	34%	25%
Asian	85	99%	88%	58%	84	93%	79%	49%	29	93%	72%	21%	26	100%	65%	58%	27	89%	63%	41%
Black/African American	169	88%	63%	23%	169	80%	54%	27%	61	85%	56%	15%	51	84%	39%	14%	50	72%	42%	20%
Hispanic	215	91%	62%	31%	215	85%	58%	32%	67	79%	55%	16%	64	88%	58%	19%	64	81%	42%	25%
Two or More Races	32	94%	81%	41%	32	97%	78%	59%	10	90%	90%	50%	11	82%	64%	27%	11	73%	64%	36%
White	466	94%	75%	39%	466	91%	68%	45%	158	91%	72%	30%	142	96%	77%	46%	140	90%	64%	40%
LEP	44	77%	36%	16%	43	60%	21%	0%	11	36%	9%	0%	15	73%	33%	7%	16	63%	19%	13%
Special Ed Indicator	57	53%	18%	4%	57	28%	5%	5%	19	21%	16%	5%	18	39%	17%	0%	18	39%	11%	6%

	Mathematics				Reading/ELA				Writing				Science				Social Studies			
	Total	Appr GL	Meets GL	Master GL	Total	Appr GL	Meets GL	Master GL	Total	Appr GL	Meets GL	Master GL	Total	Appr GL	Meets GL	Master GL	Total	Appr GL	Meets GL	Master GL
Reading Junior High	1296	92%	69%	36%	1298	91%	70%	48%	654	89%	70%	35%	644	88%	69%	48%	642	87%	62%	44%
Economic Disadvantage	348	84%	51%	17%	349	83%	49%	26%	164	78%	50%	17%	183	75%	49%	27%	183	72%	38%	24%
Asian	137	98%	91%	60%	137	95%	81%	59%	67	97%	87%	48%	71	93%	82%	62%	70	94%	79%	59%
Black/African American	294	86%	56%	27%	294	87%	59%	36%	148	91%	64%	27%	145	78%	53%	28%	145	78%	47%	32%
Hispanic	349	89%	59%	25%	350	90%	60%	38%	182	81%	57%	25%	168	85%	56%	40%	168	81%	47%	35%
Two or More Races	37	95%	65%	32%	37	95%	73%	54%	17	76%	53%	18%	20	90%	70%	55%	20	90%	60%	35%
White	475	95%	79%	43%	476	94%	82%	58%	238	92%	79%	44%	238	94%	84%	60%	237	94%	78%	55%
LEP	28	75%	36%	11%	28	57%	25%	4%	17	35%	12%	0%	11	82%	36%	27%	11	27%	18%	18%
Special Ed Indicator	82	49%	22%	6%	83	53%	28%	14%	35	43%	20%	9%	46	35%	22%	9%	46	46%	17%	11%

Section V – 2018 LCISD Estimated Results for High School Campuses

	Mathematics				Reading/ELA				Science				Social Studies			
	Total	Appr GL	Meets GL	Master GL	Total	Appr GL	Meets GL	Master GL	Total	Appr GL	Meets GL	Master GL	Total	Appr GL	Meets GL	Master GL
Foster High School	335	91%	68%	33%	1025	81%	67%	17%	481	93%	76%	38%	475	97%	85%	57%
Economic Disadvantage	142	85%	56%	21%	349	67%	47%	10%	167	87%	60%	26%	137	93%	74%	47%
Asian	26	96%	92%	69%	102	93%	84%	31%	48	94%	90%	56%	45	98%	87%	78%
Black/African American	89	89%	60%	24%	228	78%	61%	12%	105	90%	72%	34%	104	97%	81%	50%
Hispanic	133	91%	66%	29%	345	73%	52%	11%	158	92%	63%	27%	130	95%	78%	44%
Two or More Races	--	--	--	--	26	79%	75%	14%	14	100%	79%	57%	12	92%	83%	58%
White	78	92%	71%	38%	316	88%	81%	25%	152	95%	87%	43%	181	99%	92%	66%
LEP	22	77%	36%	9%	49	33%	16%	0%	19	58%	32%	5%	14	64%	21%	0%
Special Ed Indicator	38	66%	21%	8%	68	27%	10%	3%	32	63%	34%	6%	21	71%	38%	14%

	Mathematics				Reading/ELA				Science				Social Studies			
	Total	Appr GL	Meets GL	Master GL	Total	Appr GL	Meets GL	Master GL	Total	Appr GL	Meets GL	Master GL	Total	Appr GL	Meets GL	Master GL
Fulshear High School	229	89%	58%	29%	561	80%	66%	14%	293	95%	75%	32%	184	95%	84%	55%
Economic Disadvantage	62	82%	52%	26%	127	67%	50%	4%	60	92%	60%	15%	49	90%	71%	43%
Asian	--	--	--	--	29	93%	86%	31%	15	100%	87%	47%	16	100%	94%	75%
Black/African American	62	82%	44%	16%	124	65%	48%	5%	62	87%	56%	11%	35	86%	69%	31%
Hispanic	54	87%	57%	30%	136	79%	63%	12%	69	94%	72%	23%	48	96%	88%	52%
Two or More Races	--	--	--	--	18	94%	72%	6%	10	100%	100%	30%	--	--	--	--
White	97	93%	65%	39%	252	87%	73%	18%	136	98%	82%	44%	82	96%	87%	63%
LEP	10	90%	70%	30%	19	70%	35%	0%	--	--	--	--	--	--	--	--
Special Ed Indicator	22	59%	23%	9%	39	34%	17%	0%	14	79%	43%	7%	19	58%	37%	11%

	Mathematics				Reading/ELA				Science				Social Studies			
	Total	Appr GL	Meets GL	Master GL	Total	Appr GL	Meets GL	Master GL	Total	Appr GL	Meets GL	Master GL	Total	Appr GL	Meets GL	Master GL
George Ranch High School	514	92%	79%	55%	1357	82%	68%	17%	675	96%	89%	52%	683	97%	90%	62%
Economic Disadvantage	180	87%	67%	43%	398	67%	50%	8%	191	91%	77%	40%	199	91%	82%	48%
Asian	40	98%	95%	73%	131	90%	81%	31%	66	98%	94%	68%	74	97%	93%	76%
Black/African American	143	93%	79%	48%	355	75%	57%	11%	175	95%	85%	43%	174	96%	86%	51%
Hispanic	159	87%	69%	52%	345	73%	60%	10%	172	92%	81%	40%	161	94%	85%	55%
Two or More Races	--	--	--	--	27	86%	75%	25%	11	100%	100%	91%	17	100%	94%	65%
White	164	95%	84%	60%	494	90%	78%	23%	250	99%	95%	60%	253	99%	96%	72%
LEP	17	71%	53%	29%	28	22%	11%	0%	18	56%	44%	11%	14	71%	57%	29%
Special Ed Indicator	42	45%	26%	10%	81	28%	12%	0%	28	57%	39%	14%	43	67%	35%	14%

	Mathematics				Reading/ELA				Science				Social Studies			
	Total	Appr GL	Meets GL	Master GL	Total	Appr GL	Meets GL	Master GL	Total	Appr GL	Meets GL	Master GL	Total	Appr GL	Meets GL	Master GL
Lamar Con High School	472	77%	49%	21%	978	56%	40%	5%	513	79%	52%	17%	381	89%	65%	34%
Economic Disadvantage	324	73%	40%	14%	622	48%	30%	3%	334	75%	46%	11%	209	84%	59%	26%
Asian	20	85%	60%	45%	50	84%	80%	20%	27	89%	74%	52%	21	100%	90%	62%
Black/African American	124	75%	51%	21%	266	51%	34%	4%	136	76%	50%	12%	118	86%	58%	29%
Hispanic	268	75%	43%	16%	525	51%	33%	3%	280	75%	44%	13%	182	87%	62%	26%
Two or More Races	--	--	--	--	23	83%	63%	13%	12	92%	75%	25%	11	100%	64%	36%
White	50	88%	70%	38%	114	82%	68%	12%	58	95%	83%	33%	49	96%	86%	61%
LEP	70	59%	20%	3%	114	15%	2%	0%	73	48%	14%	1%	28	50%	18%	4%
Special Ed Indicator	64	41%	9%	0%	107	11%	4%	0%	70	34%	3%	0%	36	47%	17%	3%

	Mathematics				Reading/ELA				Science				Social Studies			
	Total	Appr GL	Meets GL	Master GL	Total	Appr GL	Meets GL	Master GL	Total	Appr GL	Meets GL	Master GL	Total	Appr GL	Meets GL	Master GL
Terry High School	527	83%	48%	20%	1182	60%	42%	4%	521	89%	55%	12%	471	90%	64%	31%
Economic Disadvantage	415	84%	48%	19%	869	57%	39%	4%	396	88%	51%	8%	317	88%	58%	28%
Black/African American	66	85%	48%	24%	146	57%	40%	5%	70	89%	53%	9%	64	89%	56%	27%
Hispanic	409	84%	49%	19%	909	59%	40%	3%	401	90%	53%	10%	342	91%	63%	30%
White	43	67%	37%	16%	113	72%	54%	5%	42	86%	69%	21%	59	88%	76%	36%
LEP	63	75%	33%	10%	149	17%	5%	1%	55	71%	27%	4%	38	63%	21%	3%
Special Ed Indicator	63	43%	10%	2%	121	16%	4%	0%	41	46%	17%	2%	52	50%	23%	6%

Resource Persons: Valerie Vogt, Chief Academic Officer
 Dr. Jon Maxwell, Executive Director of Student Programs
 Brian D. Moore, Director of Research, Assessment, and Accountability

**INFORMATION ITEM: 2018 STATE ACCOUNTABILITY
RATINGS AND DISTINCTION DESIGNATIONS**

2018 State Accountability Ratings and Distinction Designations are expected to be released by the Texas Education Agency on Wednesday, August 15, 2018. If received as scheduled, staff will review Ratings and Distinction Designations with the Board and will answer questions pertaining to performance.

Resource Persons: Valerie Vogt, Chief Academic Officer
Dr. Jon Maxwell, Executive Director of Student Programs
Brian D. Moore, Director of Research, Assessment, and Accountability

INFORMATION ITEM: ADVISE TEXAS PROGRAM

Texas A&M University and Lamar Consolidated Independent School District joined in a memorandum of understanding for the Advise Texas College Advising Corps Program. Advise Texas, housed at Texas A&M University, places recent college graduates of the university as college advisers in high schools state-wide. Advisers work in collaboration with high school counselors, teachers and administrators to increase college-going rates in the high schools they serve. Advisers provide admissions and financial aid advising to students and their families through one-on-one and group sessions that help students identify colleges that will serve them well; complete their admissions and financial aid applications; and enroll successfully at the college or university they eventually choose. The Advise TX program has three main goals: to increase the college-going rate at partner high schools; to expand the range of colleges and universities to which students apply and in which they enroll; and to assist principals, counselors and teachers in fostering a college-going culture.

The purpose of the MOU is to provide and appoint one adviser from the Advise TX program at the university to Terry High School.

Resource Person: Valerie Vogt, Chief Academic Officer
Dr. Terri Mossige, Assistant Superintendent of Secondary Education

Texas A&M Chapter of Advise TX Memorandum of Understanding

among

Texas Higher Education Coordinating Board, Texas A&M University, and Lamar Consolidated Independent School District

Parties

This is a Memorandum of Understanding (“MOU”) among the Texas Higher Education Coordinating Board (“THECB”), Texas A&M University (“University”), and Lamar Consolidated Independent School District (hereafter referred to as “Lamar CISD” and/or the “high school”) relating to the Advise TX College Advising Corps program (hereafter sometimes referred to as “The Advise TX program”, “Advise TX”, or as “the project”).

THECB is understood, for the purposes of requesting information necessary for the implementation of this MOU, to include the Texas Higher Education Coordinating Board and its officers, employees, designated Advise TX contractors, designated Advise TX grantees, and other designated Advise TX agents (which include Texas A&M University, the College Advising Corps (“CAC”), and CAC’s contracted evaluation team).

Lamar CISD and/or the high school(s) is understood, for the purposes of this MOU, to include:

B.F. Terry High School

Collectively hereinafter the parties to this MOU will be referred to as “Parties” or, individually, as “Party.”

Statement of Purpose and Services to be Performed

The Advise TX program is housed at chapter public and private colleges and universities across the state, including at Texas A&M University. Advise TX is a program administered by the THECB which implements the CAC program model of placing recent college graduates as full-time “near-peer” advisers in targeted Texas high schools (“Advisers”). Through grant funds provided by THECB, the University employs advisers and project staff to carry out the project. Advise TX is an education program as defined in 34 CFR § 99.3. THECB has awarded funds to Texas A&M University for the 2018-2019 academic year to continue the Advise TX program at high schools throughout the state, including at high schools in Lamar CISD. The Texas A&M University Office of Admissions serves as the University representative office for this program

Advisers work in collaboration with high school counselors, teachers, and administrators to increase college-going rates in the high schools they serve. Advisers provide admissions and financial aid advising to students and their families through one-on-one and group sessions that 1) help students identify colleges ; 2) complete their admissions and financial aid applications; and 3) with the enrollment process at the college or university of student’s choice. . The Parties agree that the Advisers are school officials pursuant to 34 CFR § 99.31(a)(1)(i)(B). The Advise TX program has three main aims: to increase the college enrollment rate at partner high schools; to expand the range of colleges and universities to which students apply and in which they enroll; and to assist principals, counselors, and teachers with fostering a culture where students pursue higher education.

One of the purposes of this MOU is to provide and appoint one Adviser (subject to funding availability) from the Advise TX College Advising Corps to each of the Lamar CISD high schools identified herein.

THECB, the University, the Lamar CISD, and each participating high school in the Lamar CISD agree to the following three main goals/aims during the project:

1. Work collaboratively to develop and implement programs and services that (a) foster access to postsecondary education and (b) include all students who wish to participate and who work in good faith to do so.
2. Work collaboratively to (a) outline current school-based efforts to foster access to postsecondary education; (b) review Advise TX programs and services to ensure that they complement and extend these existing efforts; and (c) establish clear and mutually agreeable timelines for the implementation of Advise TX programs and services.

3. See the Adviser as an enthusiastic, sympathetic, and well-trained resource for students, but not as an expert on college access or success.

An additional purpose of this MOU is to set forth the terms and conditions under which Lamar CISD will permit THECB, the University, and the Advisers to access and/or otherwise use student record data collected by Lamar CISD which contains Personally Identifiable Information (“PII”), as defined in 34 CFR § 99.3 and is therefore subject to the Family Educational Rights and Privacy Act (“FERPA”), 20 USC § 1232g (such PII is herein referred to as “FERPA Data”). Lamar CISD’s disclosure of FERPA Data to THECB, the University, and the Adviser will be for the purposes of (1) THECB and the University conducting an ongoing program evaluation pursuant to 20 USC § 1232g(b)(1)(C), (b)(3), and (b)(5); 34 CFR § 99.35 (“the Audit and Evaluation exception”) and (2) the Advisers performing an institutional service or function for which the Lamar CISD high schools would otherwise use employees pursuant to 20 USC § 1232g(b)(1)(A); 34 CFR 99.31(a)(1) (“the School Officials Exception”).

The University agrees to the following terms during the project:

1. Identify, recruit, and appoint one Adviser to serve each of the Lamar CISD high schools identified herein for an average of 40 hours per week for the period of August 13, 2018 – June 14, 2019.
2. Provide necessary and ongoing training, support, and professional development that will allow the Adviser to fulfill his or her responsibilities to the high school and its students, including to ensure the Adviser complies with the FERPA provisions in this MOU.
3. Provide assurance that all employees, subcontractors and volunteers of Advise TX who have contact with students have passed a criminal history background check current within the last year.
4. Employ an Advise TX Program Director who will (a) supervise the appointed Adviser, meeting with him or her regularly to discuss job performance and develop strategies for improvement; (b) work closely with the high school on-site liaison assigned by the Lamar CISD and/or the high school to assess the relationship between the appointed Adviser and the high school so that the Adviser is effectively serving the high school students and advancing the three main aims of Advise TX; (c) engage in frequent dialogue with partner high school around strategic collaboration and to assess progress towards the goals; (d) re-evaluate the work plan and make adjustments as needed but at least on an annual basis; (e) serve as the main liaison between the high school principal and Advise TX, meeting at least twice per year to review the collaboration and ensure that its goals are being met; (f) work with the on-site high school liaison to establish a mutually agreeable work schedule for the Adviser; and (g) visit the school at least twice per academic year.
5. Remain open to address any issues or concerns that may arise.
6. Share relevant data and research with the Lamar CISD and the high school, as the Lamar CISD and the high school may request as consistent with FERPA and the FERPA provisions in this MOU. Share relevant data and research with THECB and CAC, as THECB may request as consistent with FERPA and the FERPA provisions in this MOU.
7. Manage the administration and pay the full salary and benefits of the Adviser.
8. Provide funding support, as funding is available, to the appointed Adviser for reasonable expenses associated with Advise TX programs and services. Reasonable expenses include office supplies, photocopies, incentives for students (such as food), or college field trip costs (as consistent with federal cost circulars).
9. Work in good faith to identify funding opportunities that will sustain the collaboration between the University, the Lamar CISD and the high school beyond the current term.
10. Keep any and all student-level data provided by the Lamar CISD and the high school to the University and to the Adviser strictly confidential, in accordance with applicable local, state, and federal law, including as consistent with FERPA and the FERPA provisions in this MOU
11. Require the participation of the assigned Adviser in Advise TX activities, (for example, Advise TX training and professional development) with consideration to minimize the amount of time Advisers are absent while the high school is in session, during the regularly scheduled term period of service specified below.

The Lamar CISD and/or high school agrees to the following terms during the project:

1. Welcome the assigned Adviser and work actively to facilitate their entry into the school community by treating them as a professional member of the school.
2. Establish and maintain clear lines of communication with the Adviser and Advise TX Program Director in regards to staff policies, procedures, and expectations with which the Adviser is expected to comply (including any relevant FERPA policies).
3. Designate within each high school a Site Liaison to (a) serve as the Adviser's primary resource and advocate within the high school, facilitating the Adviser's integration into the life of the high school and providing appropriate advice and counsel; (b) work closely with the Advise TX Program Director to assess the relationship between the appointed Adviser and the high school so that the Adviser is effectively serving the high school students and advancing the three main aims of the Advising Corps; (c) participate in Adviser's annual evaluation; (d) work with the Advise TX Program Director to establish a mutually agreeable work schedule for the Adviser in accordance with the high school's regularly scheduled term period beginning on August 13, 2018 and ending June 14, 2019; (e) engage in frequent dialogue with Advise TX Program Director around strategic collaboration and to assess progress towards the goals; (f) re-evaluate the work plan and make adjustments as needed but at least on an annual basis; and (g) serve as the main liaison between the principal of the high school and the Advise TX Program Director, meeting at least twice a year to review the partnership and ensure that its goals are being met.
4. Maintain the existing staffing level of the guidance/counseling department and not make any staffing modifications suggesting the replacement of a counselor or counseling position with an Advise TX Adviser.
5. Allow the Adviser to use CAC data collection and service tools in the high school as consistent with FERPA and the FERPA provisions in this MOU.
6. Supply THECB and the University (including its Advisers and project staff) reasonable access to student-level data (name, date of birth, and year of graduation) for the purposes of advising, grant reporting, and program evaluation as consistent with FERPA and the FERPA provisions in this MOU.
7. Provide the University (including its Advisers) access to the ApplyTexas Counselor Suite for the purposes of effectively advising students.
8. Provide the University (including its Advisers and project staff) access to student transcripts and schedules, either electronically or in hard copy, for the purposes of effectively advising students as consistent with FERPA and the FERPA provisions in this MOU.
9. Work to integrate the Advise TX program with existing college access and guidance efforts at the high school.
10. Ensure Adviser is not arbitrarily assigned duties unrelated to his/her work plan such as clerical or manual labor or expected to fill temporary personnel shortages or assume *ad hoc* assignments (such as hall or cafeteria monitoring, supervising classrooms, monitoring testing, etc).
11. Ensure Adviser does not administer or serve as a proctor for any State or TSI-mandated testing (EOC/STAAR/ACCUPLACER/THEA/COMPASS, etc.)
12. Provide dedicated and appropriate working/meeting space for the Adviser, including a district computer with log-in access, a designated computer with internet access and ready access to phone and voicemail, fax, photocopier, and printer.
13. Provide the Adviser with a comprehensive high school orientation, with introductions to key staff, teachers, and administrators.
14. Provide assistance to the University (including its Adviser and project staff) with the coordination and administration of Advise TX surveys of high school students.
15. Ensure Adviser does not serve as the liaison to and/or provide direct supervision to other external partner college-access programs on behalf of the high school.

Purpose and Description of Program Evaluation to be Conducted

1. To determine the efficiency and success of the Advise TX program, the program shall be evaluated on an ongoing basis by THECB (including through its designated agent, CAC's contracted evaluation team). The results of the evaluation may be used to, among other things, improve and modify the Advise TX program. Such evaluations will enable all project participants to spur higher levels of college enrollment. The evaluation will include the following:
 - comprehensive compilation and analysis of direct outcomes for the Advise TX program

- comparative analysis of college-going rates between control schools and program-participating schools
 - assessment of increased scholarship dollars for universities and students
 - analysis and assessment of college preparation activities undertaken by high school students
 - identification of success factors that contribute to increased college-going rates and improved school morale
 - examination of the relationship between student grades, class schedules, and college enrollment
 - a qualitative and quantitative study of student awareness regarding higher education
2. For the purpose of carrying out the Advise TX evaluation, FERPA Data may need to be collected by the Lamar CISD and/or high school and disclosed to THECB as further described in the “FERPA Compliance” provision within this MOU.

FERPA Authorized Representatives and Adviser Serving as School Official

1. This MOU serves as a written agreement to designate authorized representatives, as defined in 34 CFR § 99.3, of a local educational authority, 20 USC § 7801(26)(A), to access FERPA Data in connection with an audit or evaluation of a Federal or State supported education program, as permitted by FERPA federal regulations 34 CFR § 99.35.
2. The Lamar CISD and/or high school, a local educational authority, hereby designates THECB, including its officers, employees, designated Advise TX contractors, designated Advise TX grantees (e.g., the University), and other designated Advise TX agents (e.g., CAC and CAC’s contracted evaluation team), as its authorized representatives under FERPA.
3. THECB, as an authorized representative of Lamar CISD, shall have access to the student education records of Lamar CISD pursuant to the policies and restrictions identified in the “FERPA Compliance” provision within this MOU.
4. This MOU also serves as a written agreement articulating the Adviser’s role as a school official for the Lamar CISD and/or high school, as permitted by FERPA federal regulations 34 CFR 99.31(a)(1).

FERPA Compliance

1. The Parties agree and understand that this MOU is to be strictly construed to comply with FERPA, particularly the Audit and Evaluation and the School Officials exceptions, at all times. At a minimum, the following terms and conditions will apply to all FERPA Data disclosed by Lamar CISD to THECB or the Adviser pursuant to this MOU:
 - For data disclosed to THECB, data will be collected and managed through an evaluation team contracted by the CAC, Texas A&M University College Advising Corps’ umbrella organization.
 - Data to be collected will include, but not necessarily be limited to: baseline information on the school, including college matriculation rates and student attainment of intermediary college enrollment goals (such as percent taking college entrance exams and FAFSA applications); information on enrolled students during program implementation, including identifying information (such as student name, date of birth, grade level/graduation year, grades, test scores on college entrance exams, and student schedules), intermediary goals, and college enrollment; and information on services provided to students. At the school level, the Adviser will collect data to help target and track services and evaluate the program’s success.
 - By disclosing PII from education records to THECB or the Adviser, Lamar CISD in no way assigns ownership of this data to an authorized representative or the Adviser.
 - For data disclosed to THECB, THECB shall ensure that FERPA Data is accessed by or disclosed to THECB only for the purposes of THECB conducting the program evaluation, the Advisers conducting their project work, and/or for effectuating necessary services related to the performance of the MOU. THECB shall ensure that the evaluation is conducted in a manner that does not permit FERPA Data to be accessed, disclosed, or otherwise used by anyone other than Lamar CISD and/or high school or THECB officers, employees, designated Advise TX contractors, designated Advise TX

grantees, and other designated Advise TX agents with legitimate interests in the evaluation of Advise TX or with legitimate educational interests.

- For data disclosed to THECB, THECB shall ensure that THECB officers, employees, designated Advise TX contractors, designated Advise TX grantees and other designated Advise TX agents obtain access to only those FERPA records in which they have legitimate interests and only after executing an agreement to maintain FERPA-compliant confidentiality of all data provided. Confidentiality of the data shall be maintained by THECB at all times to preclude personal identification of students who are the subject of the evaluation. All results of data analysis will be reported in aggregate. THECB shall never publically disclose or publish data in such a way that would allow individual students to be identified.
- THECB shall promptly notify Lamar CISD of any security breach that results in unauthorized access to any FERPA Data disclosed to THECB.
- THECB shall securely destroy all FERPA Data disclosed to it and all copies of FERPA Data in any format in THECB's possession once the FERPA Data is no longer needed for the evaluation for which the data was obtained or for the Advisers' work, based on appropriate federal guidelines.

2. The Parties agree to amend this MOU as necessary to comply with applicable amendments to FERPA, including the Audit and Evaluation exception, as required to ensure that the Parties remain in compliance with FERPA.

Term of MOU

This MOU begins July 1, 2018 and shall terminate on July 31, 2019.

Legal Compliance and Right to Audit

The Parties shall comply with all applicable federal, state, and local laws and regulations. The Parties understand that acceptance of funds under this MOU acts as acceptance of the authority of the State Auditor's office, THECB or any successor agency, as well as any external auditors selected by the State Auditor's office, THECB or any auditors selected by the United States to conduct an audit or investigation in connection with those funds. The Parties further agree to cooperate fully in the conduct of the audit or investigation, including promptly providing all records requested.

Sovereign Immunity

The Parties stipulate and agree that no provision of, or any part of this MOU or any subsequent amendment shall be construed: (1) as a waiver of the doctrine of sovereign immunity or immunity from suit as provided for in the Texas Constitution and the Laws of the State of Texas; (2) to extend liability beyond such liability provided for in the Texas Constitution and the Laws of the State of Texas; or (3) as a waiver of any immunity provided by the 11th Amendment or any other provision of the United States Constitution or any immunity recognized by the courts and the laws of the United States.

Applicable Law

This MOU shall be governed by the laws of the State of Texas.

Dispute Resolution

The Parties shall work together in good faith and in a timely manner to resolve disputes that might develop pursuant to the program under this MOU.

Trademark

The Parties certify and acknowledge that the Advise TX[®] and the Advise TX College Advising Corps[®] word marks and logos are the trademarks or registered trademarks of THECB. The University and Lamar CISD are responsible for including the trademark registration notice (®) on the trademarks.

Amendments

This MOU may be modified only by written amendment executed by the Parties hereto.

Termination or option to individually opt out of program participation

THECB may, by written notice to the Parties, immediately terminate this MOU for cause if any of the Parties fails to comply fully with any term or condition of this MOU, through no material fault of THECB. THECB may also terminate this MOU if project funding should become reduced, depleted, or otherwise unavailable during the term of the MOU and to the extent that THECB is unable to obtain additional funds for such purpose. All provisions regarding FERPA, the right to audit, and dispute resolution shall survive the termination of this MOU for any reason whatsoever and shall remain in full force and effect.

**AGREEMENT
BETWEEN
TEXAS A&M UNIVERSITY
AND**

Lamar Consolidated Independent School District

This AGREEMENT is entered into by and between Texas A&M University, a member of The Texas A&M University System, an agency of the State of Texas, (“TAMU”), and Lamar Consolidated Independent School District (“Lamar CISD”),

WHEREAS, the program contemplated by this AGREEMENT is of mutual interest and benefit to TAMU and to Lamar CISD, and will further the public outreach service and research objectives of TAMU in a manner consistent with its status as an agency of the State of Texas,

The parties agree as follows:

1. **STATEMENT OF WORK.** TAMU agrees to use its best efforts to coordinate support for Lamar CISD to achieve the main goals of the Advise TX program to enhance the college going culture and to increase the number of students who are pursuing higher education. A detailed summary of the Advise TX college adviser’s job description is outlined in the MOU under statement of purpose and services to be performed, which is attached to the 2018-2019 contract.

2. **PROJECT DIRECTOR.** The tasks will be supervised by the Office of Admissions, TAMU.

3. **PERIOD OF PERFORMANCE.** The program shall be conducted during the period of the 2018 – 2019 School Year. [August 13, 2018-June 14, 2019.]

4. **PRICE AND PAYMENT.** As compensation for performance under this AGREEMENT, Lamar ISD agrees to award TAMU \$10,000.00 per advisor to employ and train the advisor or provide supplies for the program. Payments shall be made by Lamar CISD in the following manner: payment shall be made within 30 days of the beginning of the contract period. Expenses incurred within the 60 day period prior to the contract period are allowed if they are directly related to these program costs.

TAMU shall contact the following address and/or person for financial inquiries:

ISD Name: Lamar Consolidated Independent School District
ISD Address: 3911 Avenue I
Rosenberg, TX 77471
Telephone: 832-223-0000
Facsimile: 832-223-0111
Attn: Dr. Thomas Randle
Superintendent

5. **DELIVERABLES.** The following deliverables are required under this AGREEMENT:

TAMU agrees to provide reports to Lamar CISD in accordance with the College Advising Corps manual and agreement.

6. NOTICES. All notices or communications to either party by the other will be delivered personally or sent by U.S. registered or certified mail, postage prepaid, addressed to such party at the following respective addresses for each and will be deemed given on the date so delivered or so deposited in the mail unless otherwise provided herein.

TAMU: Texas A&M University
Office of Admissions
MS 1265 TAMU
College Station, TX 77843-1265
Attn: J. Marcus Cooper
Telephone: (979) 458-0969
Facsimile: (979) 458-0434

XISD: Lamar Consolidated Independent School District
3911 Avenue I
Rosenberg, TX 77471
Attn: Dr. Thomas Randle
Superintendent
Telephone: 832-223-0000
Facsimile: 832-223-0111

7. EXPORT ADMINISTRATION. It is understood that TAMU is subject to United States laws and regulations controlling the export of technical data, computer software, laboratory prototypes and other commodities, and that its obligations hereunder are contingent upon compliance with applicable United States export laws and regulations. Furthermore, it is understood that the transfer of certain technical data and commodities may require a license from one or more agencies of the United States Government.

Both TAMU and Lamar CISD hereby agree and warrant that the program and development contemplated hereunder, and any exchange of technical data, computer software or other commodities resulting there from, shall be conducted in full compliance with the export control laws of the United States Government.

8. INDEPENDENT CONTRACTOR. For the purposes of this AGREEMENT and all services to be provided hereunder, the parties shall be, and shall be deemed to be, independent contractors and not agents or employees of the other party. Neither party shall have authority to make any statement, representations or commitments of any kind, or to take any action which shall be binding on the other party, except as may be explicitly provided for herein or authorized in writing.

9. SEVERABILITY. If any of the provisions of this AGREEMENT in the application thereof to any person or circumstance, is rendered or declared illegal for any reason, or shall be invalid or unenforceable, the remainder of this AGREEMENT and the application of such provision to other persons or circumstances shall not be affected thereby, but shall be enforced to the greatest extent permitted by applicable law.

10. DISPUTE RESOLUTION. The dispute resolution process provided in Chapter 2260, *Texas Government Code*, and the related rules adopted by the Texas Attorney General pursuant to Chapter 2260, shall be used by TAMU and Lamar CISD to attempt to resolve any claim for breach of contract made by Lamar CISD that cannot be resolved in the ordinary course of business. Lamar CISD shall submit written notice of a claim of breach of contract under this Chapter to the University Contracts

Officer of TAMU, who shall examine Lamar CISD's claim and any counterclaim and negotiate with Lamar ISD in an effort to resolve the claim.

11. **TERMINATION.** Either party may terminate this AGREEMENT and terminate all of its obligations pursuant to this AGREEMENT 1) if the other party fails to perform, keep and observe any terms or conditions required by this AGREEMENT to be performed and fails to cure such default in accordance with Section 16 below or 2) for convenience with thirty (30) days written notice to the other party in accordance with Section 10. In the event of termination for convenience, TAMU will be reimbursed for all costs and commitments incurred by TAMU prior to the date of termination.

12. **NOTICE OF DEFAULT.** In the event of a default, the non-defaulting party will give the defaulting party written notice, pursuant to Section 10 of this AGREEMENT, to correct such default. If the default continues for thirty (30) calendar days after receipt of such notice, the non-defaulting party may terminate this AGREEMENT by written notice to the defaulting party sent pursuant to Section 10 of this AGREEMENT.

13. **FORCE MAJEURE.** Neither party is required to perform any term, condition, or covenant of this AGREEMENT, if performance is prevented or delayed by a natural occurrence, a fire, an act of God, an act of terrorism, an act of war, or other similar occurrence, the cause of which is not reasonably within the control of either party, and which by due diligence either is unable to prevent or overcome.

14. **GOVERNING LAW.** This AGREEMENT is construed under and in accordance with the laws of the State of Texas, and is performable in Brazos County, Texas. Pursuant to §85.18, *Texas Education Code*, mandatory venue is in Brazos County for all legal proceedings against TAMU pertaining to this AGREEMENT. Nothing in this AGREEMENT should be construed as being a waiver of sovereign immunity by TAMU.

15. **NON WAIVER.** TAMU is an agency of the State of Texas and nothing in the AGREEMENT waives or relinquishes TAMU's rights to claim any exemptions, privileges, and immunities as may be provided by law.

16. **NO FINANCIAL INTEREST.** To the best of Lamar CISD's knowledge, no member of the Board of Regents of The Texas A&M University System has a direct or indirect financial interest in the transaction that is the subject of this AGREEMENT.

17. **MISCELLANEOUS.** This AGREEMENT constitutes the entire agreement between the parties relative to the subject matter, and may only be modified or amended by a written agreement signed by both parties.

ACCEPTED AND AGREED:

Lamar CISD

TEXAS A&M UNIVERSITY

Signature

Signature

Name & Title

J. Marcus Cooper
Associate Director of Admissions
Sr. Program Director, Advise TX

Date

Date

INFORMATION ITEM: DISTRICT IMPROVEMENT PLAN QUARTERLY UPDATE

Per Texas Education Code §11.252, the Board of Trustees is responsible for ensuring the District Improvement Plan (DIP) is developed, reviewed and revised annually for the purpose of improving student performance.

The Board approved District performance goals as outlined in the DIP to help ensure the District is using appropriate measures to generate success.

All plans contain a comprehensive needs assessment, which identifies priority areas in need of improvement. Based upon the developed needs assessment, the District aligns goals, objectives, strategies and resources that will be used in the current school year to improve and support student performance.

The DIP is also aligned to support the tenants of the Texas Accountability Intervention System (TAIS), and it serves as a blueprint for sustaining growth toward meeting and increasing state accountability standards.

The DIP is available on the District website for public review. The DIP may receive minor amendments from administration throughout the school year to stay in sync with continually evolving District, campus and student needs.

Submitted by: Valerie Vogt, Chief Academic Officer
Mike Rockwood, Chief of Staff

**INFORMATION ITEM: TAX COLLECTION REPORT
(AS OF JULY 31, 2018)**

- Exhibit "A" gives the LCISD collections made during the month of July 31, 2018.
- Exhibit "B" gives the total LCISD collections made this school year from September 1, 2017 through August 31, 2018.
- Exhibit "C" shows the LCISD collections made month-by-month of the 2017-18 roll as compared to prior years. Through July 31, 2018, LCISD had collected 98.9 % of the 2017-18 roll.
- Exhibit "D" shows the total collections made as compared to the amount that was budgeted for 2017-2018.
- Exhibit "E" shows the LCISD tax collection analysis for the last six years.

Resource Person: Jill Ludwig, CPA, RTSBA, Chief Financial Officer

**Lamar Consolidated ISD
Tax Collections
July 2018**

Year	Taxes Paid	Penalty & Interest	Collection Fees	Total Payments	General Fund Taxes Paid	General Fund P & I & Collection Fees	Debt Service Taxes Paid	Debt Service P & I & Collection Fees
17	\$ 691,498.12	\$ 60,074.46	\$ 50,106.02	\$ 801,678.60	\$ 517,386.05	\$ 95,054.22	\$ 174,112.07	\$ 15,126.26
16	\$ 41,968.50	\$ 11,481.79	\$ 8,989.46	\$ 62,439.75	\$ 31,401.25	\$ 17,580.29	\$ 10,567.25	\$ 2,890.96
15	\$ 10,403.16	\$ 3,625.42	\$ 2,479.42	\$ 16,508.00	\$ 7,783.76	\$ 5,191.98	\$ 2,619.40	\$ 912.86
14	\$ 4,559.96	\$ 1,405.18	\$ 889.21	\$ 6,854.35	\$ 3,411.78	\$ 1,940.59	\$ 1,148.18	\$ 353.80
13	\$ 2,904.09	\$ 786.54	\$ 482.64	\$ 4,173.27	\$ 2,172.88	\$ 1,071.14	\$ 731.21	\$ 198.04
12	\$ 2,302.08	\$ 522.75	\$ 295.60	\$ 3,120.43	\$ 1,722.44	\$ 686.72	\$ 579.64	\$ 131.63
11	\$ 509.75	\$ 177.68	\$ 137.48	\$ 824.91	\$ 374.06	\$ 267.86	\$ 135.69	\$ 47.30
10	\$ 239.56	\$ 137.51	\$ 75.41	\$ 452.48	\$ 179.08	\$ 178.20	\$ 60.48	\$ 34.72
09	\$ 322.32	\$ 367.43	\$ 137.94	\$ 827.69	\$ 253.37	\$ 426.76	\$ 68.95	\$ 78.61
08	\$ 45.52	\$ 51.41	\$ 18.47	\$ 115.40	\$ 35.77	\$ 58.88	\$ 9.75	\$ 11.00
07	\$ 259.86	\$ 326.15	\$ 105.95	\$ 691.96	\$ 200.26	\$ 357.31	\$ 59.60	\$ 74.79
06	\$ 12.97	\$ 19.32	\$ 6.45	\$ 38.74	\$ 11.15	\$ 23.05	\$ 1.82	\$ 2.72
05	\$ 323.24	\$ 516.84	\$ 167.57	\$ 1,007.65	\$ 285.62	\$ 624.25	\$ 37.62	\$ 60.16
04	\$ 141.45	\$ 144.96	\$ 0.95	\$ 287.36	\$ 124.98	\$ 129.04	\$ 16.47	\$ 16.87
03	\$ 33.18	\$ 39.34	\$ 5.49	\$ 78.01	\$ 29.90	\$ 40.94	\$ 3.28	\$ 3.89
02	\$ 28.63	\$ 52.46	\$ 11.86	\$ 92.95	\$ 25.80	\$ 59.14	\$ 2.83	\$ 5.18
01	\$ 34.46	\$ 66.80	\$ 14.81	\$ 116.07	\$ 31.05	\$ 75.01	\$ 3.41	\$ 6.60
00	\$ 25.10	\$ 55.47	\$ 12.09	\$ 92.66	\$ 22.34	\$ 61.47	\$ 2.76	\$ 6.09
99	\$ 403.07	\$ 943.19	\$ 201.94	\$ 1,548.20	\$ 364.22	\$ 1,054.22	\$ 38.85	\$ 90.91
98	\$ 1,297.56	\$ 3,191.90	\$ 673.42	\$ 5,162.88	\$ 1,199.63	\$ 3,624.43	\$ 97.93	\$ 240.89
97 & prior	\$ -	\$ -	\$ -	\$ -	\$ -	\$ -	\$ -	\$ -
Totals	\$ 757,312.58	\$ 83,986.60	\$ 64,812.18	\$ 906,111.36	\$ 567,015.39	\$ 128,505.50	\$ 190,297.19	\$ 20,293.28

**Lamar Consolidated ISD
Tax Collections
September 1, 2017-August 31, 2018
(Year-To-Date)**

Year	Original Tax	Adjustments	Adjusted Tax	Taxes Paid	Penalty & Interest	Collection Fees	Total Payments	Total Taxes 7/31/18
17	\$ 206,293,212.17	\$ 2,290,464.43	\$ 208,583,676.60	\$ 206,299,849.25	\$ 700,318.32	\$ 107,485.57	\$ 207,107,653.14	\$ 2,283,827.35
16	\$ 1,814,663.85	\$ (93,890.48)	\$ 1,720,773.37	\$ 1,004,842.06	\$ 245,662.13	\$ 247,256.08	\$ 1,497,760.27	\$ 715,931.31
15	\$ 566,874.61	\$ 61,334.96	\$ 628,209.57	\$ 160,293.72	\$ 48,291.44	\$ 32,352.85	\$ 240,938.01	\$ 467,915.85
14	\$ 339,577.64	\$ 200,203.26	\$ 539,780.90	\$ 193,329.79	\$ 24,410.80	\$ 13,418.85	\$ 231,159.44	\$ 346,451.11
13	\$ 277,679.16	\$ 203,293.33	\$ 480,972.49	\$ 176,189.10	\$ 20,146.52	\$ 9,947.75	\$ 206,283.37	\$ 304,783.39
12	\$ 265,479.02	\$ 230,394.02	\$ 495,873.04	\$ 229,438.46	\$ 17,431.31	\$ 6,675.34	\$ 253,545.11	\$ 266,434.58
11	\$ 224,190.26	\$ 44,743.08	\$ 268,933.34	\$ 62,944.35	\$ 9,241.24	\$ 2,962.73	\$ 75,148.32	\$ 205,988.99
10	\$ 181,303.11	\$ 17,374.15	\$ 198,677.26	\$ 17,378.49	\$ 7,352.02	\$ 1,783.18	\$ 26,513.69	\$ 181,298.77
09	\$ 159,154.16	\$ 5,217.66	\$ 164,371.82	\$ 6,871.05	\$ 5,775.83	\$ 1,339.58	\$ 13,986.46	\$ 157,500.77
08	\$ 153,187.47	\$ (135.44)	\$ 153,052.03	\$ 3,029.60	\$ 3,424.15	\$ 1,182.63	\$ 7,636.38	\$ 150,022.43
07	\$ 174,543.62	\$ (98,838.98)	\$ 75,704.64	\$ 1,205.56	\$ 1,522.77	\$ 513.25	\$ 3,241.58	\$ 74,499.08
06	\$ 84,556.70	\$ (486.89)	\$ 84,069.81	\$ 1,942.97	\$ 2,036.27	\$ 334.75	\$ 4,313.99	\$ 82,126.84
05	\$ 130,312.15	\$ (549.82)	\$ 129,762.33	\$ 2,007.19	\$ 2,999.65	\$ 904.37	\$ 5,911.21	\$ 127,755.14
04	\$ 52,136.73	\$ (896.06)	\$ 51,240.67	\$ 3,721.76	\$ 5,583.36	\$ 1,448.02	\$ 10,753.14	\$ 47,518.91
03	\$ 39,258.30	\$ (179.77)	\$ 39,078.53	\$ 1,653.92	\$ 2,477.97	\$ 474.79	\$ 4,606.68	\$ 37,424.61
02	\$ 25,886.38	\$ (171.61)	\$ 25,714.77	\$ 621.40	\$ 948.22	\$ 167.15	\$ 1,736.77	\$ 25,093.37
01	\$ 24,301.80	\$ (276.20)	\$ 24,025.60	\$ 986.97	\$ 1,625.97	\$ 277.12	\$ 2,890.06	\$ 23,038.63
00	\$ 21,052.70	\$ (248.59)	\$ 20,804.11	\$ 62.05	\$ 112.87	\$ 24.73	\$ 199.65	\$ 20,742.06
99	\$ 21,924.25	\$ (278.54)	\$ 21,645.71	\$ 750.88	\$ 1,553.02	\$ 289.07	\$ 2,592.97	\$ 20,894.83
98	\$ 13,781.68	\$ (267.50)	\$ 13,514.18	\$ 3,177.47	\$ 7,721.46	\$ 1,612.15	\$ 12,511.08	\$ 10,336.71
97	\$ 12,114.62	\$ (5,356.75)	\$ 6,757.87	\$ 2,395.71	\$ 6,032.20	\$ 1,234.82	\$ 9,662.73	\$ 4,362.16
96	\$ 5,144.62	\$ (4,307.22)	\$ 837.40	\$ 2,010.07	\$ 5,386.50	\$ 1,109.49	\$ 8,506.06	\$ (1,172.67)
95 & prior	\$ 17,571.87	\$ -	\$ 17,571.87	\$ 68.15	\$ 207.70	\$ 41.39	\$ 317.24	\$ 17,503.72
Totals	\$210,897,906.87	\$2,847,141.04	\$213,745,047.91	\$208,174,769.97	\$1,120,261.72	\$432,835.66	\$209,727,867.35	\$5,570,277.94

**LAMAR CONSOLIDATED INDEPENDENT SCHOOL DISTRICT
TAX COLLECTION ANALYSIS
PERCENT Y-T-D BY MONTH
FOR CURRENT LEVY ONLY**

MONTH	2017-2018	2016-2017	2015-2016	2014-2015	2013-2014	2012-13	2011-12	2010-11	2009-10	2008-09	2007-08	2006-07
SEPT	0.0%	0.0%	0.0%	0.0%	0.0%	0.0%	0.0%	0.0%	0.0%	0.0%	0.0%	0.0%
OCT	0.0%	0.0%	0.1%	0.0%	0.1%	0.0%	0.0%	0.0%	0.0%	0.0%	0.0%	0.0%
NOV	0.5%	3.2%	3.2%	2.2%	7.4%	1.9%	2.6%	3.9%	1.9%	1.7%	2.8%	2.1%
DEC	51.4%	50.3%	49.0%	45.3%	45.3%	33.1%	30.2%	33.3%	25.9%	35.4%	31.9%	29.7%
JAN	83.9%	87.2%	83.9%	82.0%	86.2%	82.9%	82.3%	84.1%	80.7%	80.4%	59.6%	76.4%
FEB	95.7%	95.6%	95.4%	95.1%	95.5%	95.5%	94.8%	94.3%	93.3%	92.8%	93.5%	93.3%
MAR	96.9%	96.9%	96.9%	96.8%	97.0%	96.8%	96.4%	96.1%	95.0%	94.8%	95.1%	94.7%
APR	97.6%	97.5%	97.6%	97.9%	97.8%	97.6%	97.1%	96.9%	96.0%	95.6%	95.9%	95.8%
MAY	98.2%	98.2%	98.4%	98.2%	98.2%	98.1%	97.9%	97.6%	96.5%	96.4%	96.7%	96.5%
JUNE	98.6%	98.6%	98.7%	98.6%	98.7%	98.6%	98.3%	98.2%	97.4%	97.2%	97.4%	97.3%
JULY	98.9%	98.9%	99.0%	98.9%	99.0%	99.0%	98.7%	98.6%	98.0%	97.9%	98.0%	97.8%
AUG		99.1%	99.2%	99.0%	99.2%	99.1%	98.9%	98.8%	98.2%	98.2%	98.2%	98.2%

**LAMAR CONSOLIDATED INDEPENDENT SCHOOL DISTRICT
2017-18 TAX COLLECTIONS
AS OF JULY 31, 2018**

TAX YEAR LCISD TAXES	SCHOOL YEAR	BUDGET AMOUNT	COLLECTIONS 7/31/2018	% OF BUDGET COLLECTED
2017	2017-2018	\$ 207,658,560	\$ 206,299,849	99.35%
2016 & Prior	2016-17 & Prior	\$ 2,150,000	\$ 1,874,921	87.21%
TOTAL		\$ 209,808,560	\$ 208,174,770	99.22%

**LAMAR CONSOLIDATED INDEPENDENT SCHOOL DISTRICT
TAX COLLECTION REPORT
AS OF JULY 31, 2018**

SCHOOL YEAR TAX YEAR	2012-13 2012	2013-14 2013	2014-15 2014	2015-16 2015	2016-17 2016	2017-18 2017
COLLECTION YEAR						
1 Orig. Levy	\$ 136,145,655	\$ 142,546,726	\$ 153,118,133	\$ 173,016,530	\$ 190,749,742	\$ 206,293,212
1 Collections	\$ 140,561,034	\$ 148,220,912	\$ 160,220,428	\$ 178,028,558	\$ 195,553,464	\$ 206,299,849
Adj. To Roll	\$ 5,652,043	\$ 6,929,880	\$ 8,680,375	\$ 6,473,810	\$ 6,618,386	\$ 2,290,464
2 Collections	\$ 739,542	\$ 739,176	\$ 1,201,706	\$ 745,585	\$ 1,004,842	
Adj. To Roll	\$ 65,612	\$ 242,601	\$ 165,920	\$ (149,323)	\$ (93,890)	
3 Collections	\$ 315,459	\$ 333,212	\$ 305,374	\$ 160,294		
Adj. To Roll	\$ 445,748	\$ (49,699)	\$ 102,657	\$ 61,335		
4 Collections	\$ 252,058	\$ 211,870	\$ 193,330			
Adj. To Roll	\$ (88,980)	\$ 113,341	\$ 200,203			
5 Collections	\$ 225,311	\$ 176,189				
Adj. To Roll	\$ 138,805	\$ 203,293				
6 Collections	\$ 229,438					
Adj. To Roll	\$ 230,394					
TOTAL:						
COLLECTIONS	\$ 142,322,843	\$ 149,681,359	\$ 161,920,837	\$ 178,934,436	\$ 196,558,307	\$ 206,299,849
ADJUSTED TAX ROLL	\$ 142,589,277	\$ 149,986,143	\$ 162,267,288	\$ 179,402,352	\$ 197,274,238	\$ 208,583,677
BALANCE TO BE COLLECTED	\$ 266,434	\$ 304,783	\$ 346,451	\$ 467,916	\$ 715,931	\$ 2,283,827
ADJ. TAXABLE VALUE	\$ 10,257,852,382	\$ 10,789,981,860	\$ 11,673,485,731	\$ 12,906,179,778	\$ 14,191,880,714	\$ 15,005,480,134
TOTAL % COLLECTIONS AS OF JULY 31, 2018	99.8%	99.8%	99.8%	99.7%	99.6%	98.9%
TAX RATE	1.39005	1.39005	1.39005	1.39005	1.39005	1.39005

**INFORMATION ITEM: CONVERSION AND REMARKETING OF THE SERIES 2014A
LAMAR CISD VARIABLE RATE UNLIMITED TAX SCHOOLHOUSE BONDS**

In May 2018, the Board of Trustees approved an Order authorizing the conversion of the Series 2014A Lamar CISD Variable Rate Unlimited Tax Schoolhouse Bonds to a New Rate Period, as well as enacting other provisions of the Order.

The voters of Lamar CISD authorized the issuance of \$249,159,215 in schoolhouse bonds in an election held November 8, 2011. As part of the voted authorization, the District sold \$90,000,000 in bonds as variable rate soft put bonds (Lamar CISD Variable Rate Unlimited Tax Schoolhouse Bonds, Series 2014A (the “Bonds”). The issuance of the Bonds as soft put bonds allowed the District to take advantage of low short-term interest rates and provided the District with the flexibility to pay off the Bonds when merited.

The Bonds were issued in 2014 with an Initial Rate Period of two years and an Initial Rate of 2.00%. Pursuant to the terms of the Order Authorizing the Issuance of the Bonds (the “Original Order”), the District was obligated to convert the Bonds from the Initial Rate Period to a different Rate Period on August 15, 2016. The Bonds were remarketed and converted, and are outstanding in a Term Rate Period ending on August 14, 2018 with an interest rate of 1.05%.

On August 7, 2018, with the assistance of the Remarketing Agent (BOK Financial Securities), and the District’s municipal advisor and bond counsel, the bonds were remarketed with a Term Rate Period of two (2) years ending on August 16, 2020. The Stepped Rate of 7% and Maximum Rate of 9% for the Bonds were confirmed as provided in the Original Order. As a result of the remarketing, the new two-year Term Rate is 1.95%, and will be effective at conversion on August 15, 2018.

Since the variable rate bonds are budgeted at an assumed rate of 4.5%, this remarketing transaction should result in reductions to debt service budget requirements of approximately \$4.3 million (net of fees) over the 2019 and 2020 fiscal years. A new Term Rate Period and Term Rate will be set in two years.

Resource person: Jill Ludwig, CPA, RTSBA, Chief Financial Officer

**INFORMATION ITEM: LAMAR CISD NEW MONEY BOND SALE,
2017 BOND REFERENDUM**

On November 7, 2017, a bond election totaling \$445,451,000 was approved by a majority of voters in the District. An order authorizing the sale of the first installment of the bonds was approved by the Board of Trustees in May 2018. These bonds were sold in a negotiated sale on June 27, 2018 by a team of seven underwriters, with the managing firm being Wells Fargo Securities. A negotiated sale process allowed the underwriters to place the bonds with buyers commanding varying terms such maturities, rates, etc. The District has used this method since 2003, and it has resulted in low interest rates and favorable maturities which translates into the lowest possible tax rates for the community.

The recent sale transaction resulted in continuing to capture historically low interest rates. The bonds, used to finance projects the District included in the 2017 bond referendum, were sold with a par amount of \$289,260,000 and the Total Interest Cost (TIC) was 3.79%. The Bonds were sold at a premium; therefore, the District will receive \$300,000,000 for new projects. This will leave \$145,451,000 for future installment(s) of bonds from the November 7, 2017 voted authorization. The transaction closed on July 24, 2018.

During the due diligence phase of the sale process, the District's underlying bond ratings were affirmed at "Aa2" and "AA" by Moody's and S&P, and since the bonds are guaranteed by the Texas Permanent School Fund, they will also carry the highest ratings for municipal bonds of "Aaa" and "AAA."

For comparative purposes, the TIC of 3.79% achieved on this sale was tremendous in light of the recent rate hikes in the market, and is highly comparable to the TIC of 3.76% realized on the \$93.0 million sold in 2017, and the TIC of 3.95% attained for the \$142.045 million sold in 2015.

Submitted by: Jill Ludwig, CPA, RTSBA, Chief Financial Officer

INFORMATION ITEM: PAYMENTS FOR CONSTRUCTION PROJECTS

Below is a list of invoices that have been approved for payment.

ACI (Support Services M&O)	Application # 3	\$	499.00
C.A. Walker Construction (Support Services Center)	Application # 11	\$	130,802.58
C.A. Walker Construction (Support Services Center)	Application # 12	\$	437,038.95
Charlie Kalkomey (Culver ES)	Application # 2	\$	7,150.00
City of Fulshear (Roberts MS)	Application # 1	\$	167,070.00
Drymalla Construction (Carter ES)	Application # 12	\$	1,286,917.50
Drymalla Construction (Carter ES)	Application # 13	\$	1,141,096.30
Drymalla Construction (Culver ES)	Application # 1	\$	1,357,628.85
Drymalla Construction (Culver ES)	Application # 2	\$	878,614.15
Drymalla Construction (Fulshear HS Shell Space)	Application # 2	\$	350,255.50
Drymalla Construction (Fulshear HS Shell Space)	Application # 3	\$	359,375.50
Drymalla Construction (Roberts MS)	Application # 1	\$	980,103.60
Drymalla Construction (Roberts MS)	Application # 2	\$	986,928.40

Engineered Air Balance (Carter ES)	Application # 3	\$	17,850.00
Engineered Air Balance (Fulshear HS Shell Space)	Application # 1	\$	4,650.00
HVJ Associates, Inc. (Foster HS Water Plant Upgrades)	Application # 1	\$	1,187.50
HVJ Associates, Inc. (Foster HS Water Plant Upgrades)	Application # 2	\$	1,377.50
HVJ Associates, Inc. (Foster HS Water Plant Upgrades)	Application # 3	\$	1,785.00
Johnson Controls (Various campuses HVAC)	Application # 5	\$	63,657.12
KCI Technologies (Foster HS Water Well)	Application # 5	\$	8,640.00
Millis Construction (Terry HS Baseball/Softball Complex)	Application # 10	\$	103,204.44
Millis Construction (Terry HS Baseball/Softball Complex)	Application # 11	\$	5,375.03
PBK Architects (Bentley ES)	Application # 23	\$	2,590.06
PBK Architects (Campbell/Dickinson Track & Turf)	Application # 8	\$	618.45
PBK Architects (Foster HS Natatorium)	Application # 17	\$	7,389.47
PBK Architects (Foster HS Natatorium)	Application # 18	\$	14,778.94
PBK Architects (Foster HS Natatorium – Reimbursables)	Application # 5	\$	950.00
PBK Architects (Foster HS Natatorium – Reimbursables)	Application # 6	\$	2,168.14

PBK Architects (Foster HS Security Vestibule)	Application # 1	\$	3,973.80
PBK Architects (Foster HS Security Vestibule)	Application # 2	\$	264.92
PBK Architects (Foster HS Security Vestibule)	Application # 3	\$	1,725.35
PBK Architects (Foster HS Security Vestibule)	Application # 4	\$	350.83
PBK Architects (Foster HS Security Vestibule)	Application # 5	\$	561.32
PBK Architects (Foster HS Security Vestibule)	Application # 6	\$	140.33
PBK Architects (Fulshear HS Natatorium)	Application # 18	\$	5,564.26
PBK Architects (Fulshear HS Natatorium)	Application # 19	\$	11,128.52
PBK Architects (Fulshear HS Natatorium – Reimbursables)	Application # 5	\$	553.70
PBK Architects (Fulshear HS Natatorium – Reimbursables)	Application # 6	\$	1,718.15
PBK Architects (Fulshear HS Shell Space – Reimbursables)	Application # 3	\$	3,319.84
PBK Architects (Fulshear HS Shell Space – Reimbursables)	Application # 4	\$	250.00
PBK Architects (Fulshear HS Shell Space – Reimbursables)	Application # 5	\$	953.91
PBK Architects (George JHS Security Vestibule)	Application # 1	\$	2,587.80
PBK Architects (George JHS Security Vestibule)	Application # 2	\$	172.52

PBK Architects (George JHS Security Vestibule)	Application # 3	\$	2,996.01
PBK Architects (George JHS Security Vestibule)	Application # 4	\$	338.61
PBK Architects (George JHS Security Vestibule)	Application # 5	\$	541.77
PBK Architects (George JHS Security Vestibule)	Application # 6	\$	135.44
PBK Architects (George Ranch HS Natatorium)	Application # 17	\$	4,630.08
PBK Architects (George Ranch HS Natatorium)	Application # 18	\$	10,417.68
PBK Architects (George Ranch HS Natatorium – Reimbursables)	Application # 5	\$	1,718.15
PBK Architects (Lamar CHS Security Vestibule)	Application # 1	\$	2,432.40
PBK Architects (Lamar CHS Security Vestibule)	Application # 2	\$	162.16
PBK Architects (Lamar CHS Security Vestibule)	Application # 3	\$	1,528.68
PBK Architects (Lamar CHS Security Vestibule)	Application # 4	\$	242.55
PBK Architects (Lamar CHS Security Vestibule)	Application # 5	\$	446.28
PBK Architects (Lamar CHS Security Vestibule)	Application # 6	\$	38.81
PBK Architects (Lindsey ES)	Application # 23	\$	5,429.42
PBK Architects (Roberts MS)	Application # 8	\$	41,331.67

PBK Architects (Roberts MS – Reimbursables)	Application # 4	\$	10,340.89
PBK Architects (Roberts MS – Reimbursables)	Application # 5	\$	250.00
PBK Architects (Roberts MS – Reimbursables)	Application # 6	\$	3,046.71
PBK Architects (Support Services)	Application # 14	\$	4,722.35
PBK Architects (Terry HS Baseball/Softball Complex)	Application # 14	\$	515.83
PBK Architects (Terry HS Baseball/Softball Complex)	Application # 15	\$	773.74
PBK Architects (Terry HS Baseball/Softball Complex – Reim)	Application # 6	\$	4,000.00
Pure Speed Lightwave (Carter ES)	Application # 1	\$	81,178.00
Raba Kistner (Foster HS Natatorium)	Application # 8	\$	2,459.25
Raba Kistner (Foster HS Natatorium)	Application # 9	\$	494.50
Raba Kistner (Fulshear HS Natatorium)	Application # 10	\$	4,873.75
Raba Kistner (George Ranch HS Natatorium)	Application # 10	\$	973.50
Raba Kistner (George Ranch HS Natatorium)	Application # 11	\$	1,141.50
Terracon (Carter ES)	Application # 14	\$	9,627.50
Terracon (Culver ES)	Application # 2	\$	125.00

Terracon (Culver ES)	Application # 3	\$	8,353.75
Terracon (HS/JHS Complex #6)	Application # 1	\$	2,850.00
Terracon (Jordan Ranch ES)	Application # 2	\$	3,800.00
Terracon (Jordan Ranch ES)	Application # 1	\$	2,450.00
Terracon (Roberts MS)	Application # 2	\$	10,159.75
Terracon (Roberts MS)	Application # 3	\$	14,074.00
Terracon (Support Services)	Application # 2	\$	2,370.00
Terracon (Support Services)	Application # 3	\$	2,370.00
Terracon (Support Services)	Application # 4	\$	10,926.50
Terracon (Terry HS Baseball Complex)	Application # 9	\$	1,662.00
Terracon (Veranda ES)	Application # 1	\$	2,450.00
Turner Construction (Foster HS Natatorium)	Application # 10	\$	495,452.08
Turner Construction (Foster HS Natatorium)	Application # 11	\$	768,858.84
Turner Construction (Fulshear HS Natatorium)	Application # 10	\$	631,980.19
Turner Construction (Fulshear HS Natatorium)	Application # 11	\$	691,149.74

Turner Construction (George Ranch HS Natatorium)	Application # 10	\$	587,976.09
Turner Construction (George Ranch HS Natatorium)	Application # 11	\$	824,113.26
VLK Architects (Carter ES)	Application # 13	\$	24,066.18
VLK Architects (Carter ES – Reimbursables)	Application # 12	\$	148.21
VLK Architects (Culver ES)	Application # 4	\$	21,073.89
VLK Architects (Culver ES)	Application # 5	\$	16,382.02
VLK Architects (Culver ES – Reimbursables)	Application # 4	\$	9,470.36
VLK Architects (Culver ES – Reimbursables)	Application # 5	\$	686.71
VLK Architects (LCHS Band Hall)	Application # 9	\$	3,000.00
VLK Architects (LCHS Band Hall – Reimbursables)	Application # 8	\$	42.78
VLK Architects (THS Band Hall)	Application # 9	\$	4,200.00
VLK Architects (THS Band Hall – Reimbursables)	Application # 8	\$	42.79
Vanir, Rice & Gardner (2014 Bond Program)	Application # 35	\$	133,078.00
Vanir, Rice & Gardner (2014 Bond Program)	Application # 36	\$	99,547.00

Resource person: Leslie Haack, Deputy Superintendent of Support Services
Kevin McKeever, Executive Director of Facilities & Planning

EXECUTIVE SUMMARY

Bond Sale 1	Current Budget	Committed	Projected Commitments	Actuals Paid	Estimated Cost at Completion
Carl Briscoe Bentley Elementary (#24)	22,010,055.00	22,004,459.00	5,596.00	21,327,662.23	22,010,055.00
Kathleen Joerger Lindsey Elementary (#25)	23,770,861.00	21,962,813.40	1,808,047.60	20,232,818.13	21,962,814.00
Don Carter Elementary School (#26)	24,959,404.00	23,047,557.59	1,911,846.41	20,891,929.23	24,959,404.00
FHS Baseball	40,000.00	29,250.00	10,750.00	29,250.00	29,250.00
FHS Water Plant	990,000.00	718,150.00	271,850.00	644,329.50	990,000.00
HVAC Web Controls	1,056,000.00	539,600.00	516,400.00	446,302.24	1,056,000.00
LCHS Band Hall	700,000.00	647,184.00	52,816.00	545,245.41	700,000.00
Pink Elementary- Foundation	1,056,000.00	1,046,744.57	9,255.43	1,040,409.39	1,046,744.57
Natorium - Foster High School	8,648,880.00	8,623,654.19	25,225.81	6,880,956.78	8,648,880.00
Natorium - Fulshear High School	8,832,167.00	8,683,939.00	148,228.00	6,941,630.20	8,832,167.00
Natorium - George Ranch High School	9,086,569.00	9,001,276.00	85,293.00	6,831,886.41	9,086,569.00
Support Services Center	12,146,000.00	11,434,545.74	711,454.26	6,715,305.60	12,146,000.00
THS Band Hall	700,000.00	659,835.00	40,165.00	600,739.89	700,000.00
*THS Baseball	2,400,000.00	2,399,200.42	799.58	2,380,882.49	2,399,200.00
Sub Total - Bond Sale 1	116,395,936.00	110,798,208.91	5,597,727.09	95,509,347.50	114,567,883.57
Bond Sale 2					
Thomas R. Culver, III Elementary School	24,959,404.00	21,685,921.00	3,273,483.00	3,823,317.06	24,959,404.00
Fletcher Morgan Elementary School	26,207,374.00	1,002,385.00	25,204,989.00	458,562.00	26,207,374.00
James W. Roberts Middle School	22,342,493.00	21,393,732.00	948,761.00	2,405,666.21	22,342,493.00
Fulshear HS Shell	3,849,077.00	1,727,045.00	2,122,032.00	1,133,645.49	3,849,077.00
Satellite Ag Barn	3,786,750.00	189,000.00	3,597,750.00	0.00	3,786,750.00
Sub Total - Bond Sale 2	81,145,098.00	45,998,083.00	35,147,015.00	7,821,190.76	81,145,098.00
Grand Total	197,541,034.00	156,796,291.91	40,744,742.09	103,330,538.26	195,712,981.57

* Budget increased at August 18, 2016 Board Meeting

Additional Projects	Current Budget	Committed	Projected Commitments	Actuals Paid	Estimated Cost at Completion
Access Controls	800,000.00	596,798.00	203,202.00	476,734.01	800,000.00
Huggins Elementary School	700,000.00	656,442.48	43,557.52	648,178.55	654,162.48
Chiller Replacement	1,200,000.00	1,027,572.50	172,427.50	1,024,058.27	1,027,572.50
Site Lighting	1,600,000.00	1,383,710.00	216,290.00	1,136,756.35	1,600,000.00
Grand Total	4,300,000.00	3,664,522.98	635,477.02	3,285,727.18	4,081,734.98

PROGRAM OVERVIEW

Vanir | Rice & Gardner, A Joint Venture, is serving as the Program Manager for the 2014 Bond Program for Lamar CISD. In this role, we manage individual projects, and coordinate with architects and contractors. We are the liaison between LCISD Administration, Departments, and Schools and coordinate all activities necessary to complete each project.

We also provide program-wide oversight and look for efficiencies, cost reduction, and quality assurance opportunities.

Accomplishments This Month:

- Closed out Terry High School Baseball / Softball Complex contract.

DON CARTER ELEMENTARY SCHOOL



SCHEDULE MILESTONES:

- Current Phase: Construction
- Construction Start: May 30, 2017
- Construction Completion: July 29, 2018

OVERVIEW:

- Construction is 99% complete
- Certificate of Occupancy expected on July 29, 2018
- Furniture installation is scheduled to begin on August 1, 2018
- Landscaping is complete

THOMAS R. CULVER III ELEMENTARY SCHOOL



SCHEDULE MILESTONES:

- Current Phase: Construction
- Construction Start: May 2018
- Construction Completion: July 2019

OVERVIEW:

- Construction is 12% complete
- Drilled piers installation is complete
- Building underground utilities and grade beams installation are progressing
- Pre-cast deck planks installation is progressing
- Submittals are being prepared and processed

ROBERTS MIDDLE SCHOOL



SCHEDULE MILESTONES:

- Current Phase: Construction
- Construction Start: May 2018
- Construction Completion: July 2019

OVERVIEW:

- Construction has begun
- Site Utilities installation has begun
- Drilled piers have been poured
- Grade beams are 75% complete

FULSHEAR HIGH SCHOOL SHELL SPACE



SCHEDULE MILESTONES:

- Current Phase: Construction
- Construction Start: May 2018
- Construction Completion: August 2018

OVERVIEW:

- Construction is 85% complete
- Classroom casework has been installed
- Science room casework being installed
- Lights have been installed

MAINTENANCE & OPERATIONS FACILITY



SCHEDULE MILESTONES:

- Current Phase: Punch List

OVERVIEW:

- Maintenance has occupied the new facility.
- Punch list corrections are underway.

SUPPORT SERVICES FACILITY



SCHEDULE MILESTONES:

- Current Phase: Construction
- Construction Start: May 2018
- Construction Completion: December 2018

OVERVIEW:

- Demolition work is progressing
- Loading bay connector pad is complete
- Mechanical, electrical and plumbing rough-in installation is progressing

BAND HALL ADDITIONS

Terry High School



SCHEDULE MILESTONES:

- Current Phase: Punch List/Close Out

Lamar Consolidated High School



OVERVIEW:

- Currently finalizing Punch List Items

FOSTER HIGH SCHOOL WATER PLANT UPGRADES



SCHEDULE OVERVIEW:

- Current Phase: Punch List/Close-out
- Construction Start: 4th Quarter 2017
- Construction Completion: March 2018

OVERVIEW:

- All construction is complete
- Waiting on TCEQ approval to begin use of the new water well and storage tank

NATATORIUMS

George Ranch High School | Foster High School | Fulshear High School



George Ranch High School



Fulshear High School

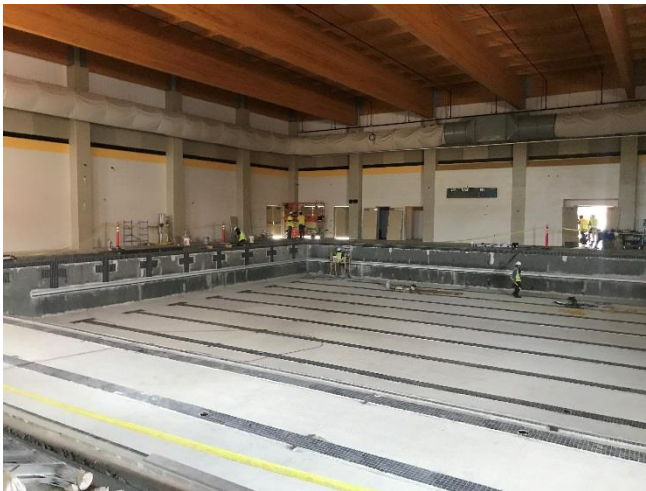

Foster High School



SCHEDULE MILESTONES:

- Current Phase: Construction
- Construction Start: July 2017
- Construction Completion: August 2018

OVERVIEW:

- Pool tile has been completed at George Ranch
- Pool tile has been completed and prepping for pool plaster at Foster
- Outside HVAC units have been connected at Fulshear
- Final pool fill is complete at Fulshear

HVAC WEB-BASED CONTROLS



SCHEDULE OVERVIEW:

- Current Phase: Close-out

OVERVIEW:

- HVAC Controls are complete at all schools
- Currently working on final Punch List and close out requirements

ACCESS CONTROLS



SCHEDULE OVERVIEW:

- Current Phase: Punch List
- Construction Start: 4th Quarter 2017
- Construction Completion: August 2018

OVERVIEW:

- Phase 1 installation at school locations is in final testing phase to confirm operation
- Staff ID badges are being tested at all schools
- Phase 2 sites have been added – Door hardware has been ordered

SITE LIGHTING



SCHEDULE OVERVIEW:

- Current Phase: Construction
- Construction Start: 4th Quarter 2017
- Construction Completion: September 2018

OVERVIEW:

- Original scope of work is complete
 - Final inspections and night audits to confirm all lights are operating is underway
 - Phase 2 sites have been added and additional light fixtures have been ordered
-

SATELLITE AG BARN #3

SCHEDULE MILESTONES:

- Current Phase: Program Development
- Construction Start: Pending Site Selection

OVERVIEW:

- Satellite Ag Barn #2 and #3 have been programmed together.
 - A site for the Satellite Ag Barn #3 has not been selected.
 - Project is on hold until a site has been identified.
-

FUTURE PROJECTS

OVERVIEW:

- 2014 Bond Sale 2 Remaining Project:
 - Morgan Elementary #28

COMPLETED PROJECTS

Foster High School Baseball Scoreboard	Completed March 2016
Huggins Elementary School New Parent Drive	Completed May 2017
New Lindsey Elementary School	Completed October, 2017
Pink Elementary School Repairs	Completed November 2017
Chiller Replacement at six schools	Completed November 2017
Bentley Elementary School	Completed May 2018
Baseball Complex Renovations at Terry HS	Completed June 2018

EXECUTIVE SUMMARY

Bond Sale 1	Current Budget	Committed	Projected Commitments	Actuals Paid	Estimated Cost at Completion
Carl Briscoe Bentley Elementary (#24)	22,010,055.00	22,004,459.00	5,596.00	21,327,662.23	22,010,055.00
Kathleen Joerger Lindsey Elementary (#25)	23,770,861.00	21,962,813.40	1,808,047.60	20,238,247.55	21,962,814.00
Don Carter Elementary School (#26)	24,959,404.00	23,047,557.59	1,911,846.41	20,997,446.62	24,959,404.00
FHS Baseball	40,000.00	29,250.00	10,750.00	29,250.00	29,250.00
FHS Water Plant	990,000.00	718,150.00	271,850.00	644,329.50	990,000.00
HVAC Web Controls	1,056,000.00	539,600.00	516,400.00	446,302.24	1,056,000.00
LCHS Band Hall	700,000.00	683,092.00	16,908.00	545,245.41	700,000.00
Pink Elementary- Foundation	1,056,000.00	1,046,744.57	9,255.43	1,040,409.39	1,046,744.57
Natorium - Foster High School	8,648,880.00	8,623,654.19	25,225.81	7,711,132.70	8,648,880.00
Natorium - Fulshear High School	8,832,167.00	8,694,984.00	137,183.00	7,686,876.66	8,832,167.00
Natorium - George Ranch High School	9,086,569.00	9,001,276.00	85,293.00	7,713,624.88	9,086,569.00
Support Services Center	12,146,000.00	11,434,545.74	711,454.26	7,177,716.61	12,146,000.00
THS Band Hall	700,000.00	691,067.00	8,933.00	600,739.89	700,000.00
*THS Baseball	2,400,000.00	2,399,200.42	799.58	2,385,656.23	2,400,000.00
Sub Total - Bond Sale 1	116,395,936.00	110,876,393.91	5,519,542.09	98,544,639.91	114,567,883.57
Bond Sale 2					
Thomas R. Culver, III Elementary School	24,959,404.00	21,685,921.00	3,273,483.00	3,855,889.54	24,959,404.00
Fletcher Morgan Elementary School	26,207,374.00	1,002,385.00	25,204,989.00	458,562.00	26,207,374.00
James W. Roberts Middle School	22,342,493.00	21,393,732.00	948,761.00	3,552,975.88	22,342,493.00
Fulshear HS Shell	3,849,077.00	1,727,045.00	2,122,032.00	1,133,645.49	3,849,077.00
Satellite Ag Barn	3,786,750.00	189,000.00	3,597,750.00	0.00	3,786,750.00
Sub Total - Bond Sale 2	81,145,098.00	45,998,083.00	35,147,015.00	9,001,072.91	81,145,098.00
Grand Total	197,541,034.00	156,874,476.91	40,666,557.09	107,545,712.82	195,712,981.57

* Budget increased at August 18, 2016 Board Meeting

Additional Projects	Current Budget	Committed	Projected Commitments	Actuals Paid	Estimated Cost at Completion
Access Controls	800,000.00	596,798.00	203,202.00	476,734.01	800,000.00
Huggins Elementary School	700,000.00	656,442.48	43,557.52	648,178.55	654,162.00
Chiller Replacement	1,200,000.00	1,027,572.50	172,427.50	1,024,058.27	1,027,573.00
Site Lighting	1,600,000.00	1,383,710.00	216,290.00	1,136,756.35	1,600,000.00
Grand Total	4,300,000.00	3,664,522.98	635,477.02	3,285,727.18	4,081,735.00

PROGRAM OVERVIEW

Vanir | Rice & Gardner, A Joint Venture, is serving as the Program Manager for the 2014 Bond Program for Lamar CISD. In this role, we manage individual projects, and coordinate with architects and contractors. We are the liaison between LCISD Administration, Departments, and Schools and coordinate all activities necessary to complete each project.

We also provide program-wide oversight and look for efficiencies, cost reduction, and quality assurance opportunities.

DON CARTER ELEMENTARY SCHOOL



DON CARTER ELEMENTARY SCHOOL



SCHEDULE MILESTONES:

- Current Phase: Construction
- Construction Start: May 30, 2017
- Construction Completion: August 1, 2018

OVERVIEW:

- Construction is 99% complete
- Obtained Certificate of Occupancy
- Building is ready for Furniture delivery scheduled to begin on August 1, 2018
- Landscaping is complete

THOMAS R. CULVER III ELEMENTARY SCHOOL



SCHEDULE MILESTONES:

- Current Phase: Construction
- Construction Start: May 2018
- Construction Completion: July 2019

OVERVIEW:

- Construction is 20% complete
- Drilled piers are complete
- Building underground utilities and grade beams installation are complete
- Pre-cast deck planks installation is progressing

ROBERTS MIDDLE SCHOOL



SCHEDULE MILESTONES:

- Current Phase: Construction
- Construction Start: May 2018
- Construction Completion: July 2019

OVERVIEW:

- Construction is 15% complete
- Grade beams are 95% complete
- Concrete planks installation is 50% complete

FULSHEAR HIGH SCHOOL SHELL SPACE



SCHEDULE MILESTONES:

- Current Phase: Construction
- Construction Start: May 2018
- Construction Completion: August 2018

OVERVIEW:

- Construction is 95% complete
- Smart Boards have been installed
- Flooring and vinyl wall covering is complete
- Ceiling tiles have been installed

MAINTENANCE & OPERATIONS FACILITY



SCHEDULE MILESTONES:

- Current Phase: Punch List

OVERVIEW:

- Maintenance has occupied the new facility
- Punch list corrections are underway

SUPPORT SERVICES FACILITY



SCHEDULE MILESTONES:

- Current Phase: Construction
- Construction Start: May 2018
- Construction Completion: December 2018

OVERVIEW:

- Demolition work is progressing
- Loading bay grade beams have been formed
- Mechanical, electrical and plumbing rough-in installation is progressing
- Exterior sheathing installation is progressing

BAND HALL ADDITIONS

Terry High School



SCHEDULE MILESTONES:

- Current Phase: Punch List/Close Out

Lamar Consolidated High School



OVERVIEW:

- Punch List Items are nearing completion
- Sound Doors have been repaired and waiting for final seals to be installed

FOSTER HIGH SCHOOL WATER PLANT UPGRADES



SCHEDULE OVERVIEW:

- Current Phase: Punch List/Close-out
- Construction Start: 4th Quarter 2017
- Construction Completion: March 2018

OVERVIEW:

- All construction is complete
- Waiting on TCEQ approval to begin use of the new water well and storage tank

NATATORIUMS

George Ranch High School | Foster High School | Fulshear High School



George Ranch High School



Fulshear High School



Foster High School



SCHEDULE MILESTONES:

- Current Phase: Construction
- Construction Start: July 2017
- Construction Completion: August 2018

OVERVIEW:

- All 3 pools have been filled
- HVAC equipment is ready for startups
- HVAC controls installation is complete
- Final grading and sidewalks are complete

HVAC WEB-BASED CONTROLS



SCHEDULE OVERVIEW:

- Current Phase: Close-out

OVERVIEW:

- HVAC Controls are complete at all schools
- Currently working on final Punch List and close out requirements

ACCESS CONTROLS



SCHEDULE OVERVIEW:

- Current Phase: Punch List
- Construction Start: 4th Quarter 2017
- Construction Completion: August 2018

OVERVIEW:

- Phase 1 installation at school locations is in final testing phase to confirm operation
- Staff ID badges are being tested at all schools
- Phase 2 sites have been added – Door hardware has been ordered

SITE LIGHTING



SCHEDULE OVERVIEW:

- Current Phase: Construction
- Construction Start: 4th Quarter 2017
- Construction Completion: September 2018

OVERVIEW:

- Original scope of work is complete.
- Currently working
- Phase 2 sites have been added and additional light fixtures have been ordered

SATELLITE AG BARN #3

SCHEDULE MILESTONES:

- Current Phase: Program Development
- Construction Start: Pending Site Selection

OVERVIEW:

- Satellite Ag Barn #2 and #3 have been programmed together
- A site for the Satellite Ag Barn #3 has not been selected
- Project is on hold until a site has been identified

FUTURE PROJECTS

OVERVIEW:

- 2014 Bond Sale 2 Remaining Project:
 - Morgan Elementary #28

COMPLETED PROJECTS

Foster High School Baseball Scoreboard	Completed March 2016
Huggins Elementary School New Parent Drive	Completed May 2017
New Lindsey Elementary School	Completed October, 2017
Pink Elementary School Repairs	Completed November 2017
Chiller Replacement at six schools	Completed November 2017
Bentley Elementary School	Completed May 2018
Baseball Complex Renovations at Terry HS	Completed June 2018

INFORMATION ITEM: 2017 BOND REFERENDUM CONSTRUCTION UPDATE

BOND UPDATE:

The first sale of bonds has taken place and funds are available.

AUSTIN ES & SEGUIN ECC RE-ROOFING

Austin ES:

Contractor: Ally Roofing Services

Substantial Completion Date: October 15, 2018

- The old roof is scheduled to be removed by August 25, 2018

Seguin ECC:

Contractor: Argio Roofing & Construction

Substantial Completion Date: October 15, 2018

- Half of the roof is scheduled to be removed by August 25, 2018

CLASSROOM INTRUDER EQUIPMENT INSTALL & RETROFIT

Contractor: Acme Architectural Hardware, Inc.

- Contractor has been given a notice to proceed and hardware is on order

TERRY HS & GEORGE JHS NEW SERVING LINES

Terry HS new cafeteria serving line:

- New serving line is in fabrication currently
- Scheduled to begin installation week of August 13, 2018
- Completion by August 23, 2018

George JHS cafeteria serving line:

- ISI Commercial Refrigeration, LLC purchase agreement approved show drawings are in progress

HS #6 & JHS #6

- Initial planning meeting with architect, PBK, was held July 26, 2018 and planning has begun
- Substantial competition is scheduled for June 15, 2021
- The RFP for Construction Manager at Risk is scheduled to be advertised starting August 11, 2018

Resource Persons: Leslie Haack, Deputy Superintendent of Support Services
Kevin McKeever, Executive Director of Facilities & Planning

INFORMATION ITEM: PROJECTS FUNDED BY 2011 AVAILABLE BOND FUNDS

The list below are projects that the Board has approved to move forward with 2011 available funds:

DISTRICT FENCE PROJECT:

CSP #37-2016ML was approved at the September 2016 Regular Board Meeting. This project is now complete and closed.

Project Budget \$450,000

CHILLER REPLACEMENT PROJECT:

VANIR Rice & Gardner are managing this project. Estes, McClure and Associates were approved at the September 2016 Regular Board Meeting. CSP 03-2017VRG was Board approved in November 2016 to American Mechanical Services. Project is complete.

Project budget \$1,200,000

PARKING LOT LIGHTING RETROFIT:

VANIR Rice & Gardner are managing this project. Siemens has completed the original scope. Final inspections and night audits are underway. The fixtures for the phase 2 sites has been ordered.

Project Budget \$1,600,000

HUGGINS PARKING AND PARENT DROPOFF:

VANIR Rice & Gardner are managing this project. This project is complete. Substantial Completion was January 17th. Project is complete and closed.

Project Budget \$700,000

ACCESS CONTROL PROJECT:

VANIR Rice & Gardner are managing this project. KCI Technology has completed final documents and RF Quotes have been received. Bowie Elementary School has been installed and working. Phase 1 is in final testing phase. Staff ID badges are being tested at all schools. Phase 2 hardware has been ordered.

Access Control Budget \$800,000

TERRY HIGH BASEBALL PROJECT:

This project is a 2014 Bond project managed by VANIR Rice & Gardner Notice This project is now complete.

Additional Budget of \$1,425,000

TOTAL BUDGET FOR AVAILABLE FUND PROJECTS = \$6,175,000

Resource Persons: Leslie Haack, Deputy Superintendent of Support Services
Kevin McKeever, Executive Director of Facilities & Planning

INFORMATION ITEM: TRANSPORTATION UPDATE

PERSONNEL CHANGES:

**TRANSPORTATION DEPARTMENT
JUNE / JULY 2018 BOARD UPDATE**

PERSONNEL CHANGES

The following changes took place during the summer:

Trainees hired:	9
Drivers leaving department:	6
Full time drivers hired:	0
Drivers waiting driving test:	2
Bus aides hired:	0

Christine Jaime, former assistant director of transportation at Friendswood ISD was hired as Special Needs Manager and started June 14.

Hiring Incentives Paid	Employee	Referer
Initial	3	0
Six Month	6	3

ACCIDENTS

<u>Date</u>	<u>Bus #</u>	<u>Action</u>	<u>Location</u>	<u>Preventable</u>	<u>Experience</u>
180606	118	Car came into bus lane	Ave H and Lane	Non	4 yrs
180621	417427	Turning and hit car bumper	Mustang Ave.	Preventable	2.5 yrs
180720	317711	Passing truck hit bus mirror	Clinton Dr. (Houston)	Non	5 yrs

FIELD TRIPS

Site	Number of Trips	Bus Miles	Sped Bus Miles	Truck Miles	White Fleet Miles
Rosenberg	136	10,690	131	674	1204
Fulshear	54	2924	26	0	2381

VEHICLE MAINTENANCE

6 Road calls were made for buses needing roadside assistance.

ROUTING AND SCHEDULING

We had the following routes in operation for summer school:

Special Needs

Extended School Year	21
Avondale & ABC West	1
Deaf Ed Dulles	1

Regular

PreK and K Smith	14
Arrendondo	6
LJH and LCHS	7 with 7 mid day runs

No additional routes were used for displaced students

TRAINING AND OTHER EVENTS

Six members of the transportation management team attended the Texas Association for Pupil Transportation Conference and Trade Show in June in Corpus Christi, Texas. A total of 10 certification classes were taken. David McMillian, Fleet Manager for Lamar CISD taught classes at the Texas Association of School Bus Technicians held concurrently with the TAPT conference. Two Lamar CISD mechanics attended classes at the summer conference and took 4 of the TASBT training classes. Lamar CISD hosted a school bus electrical/charging class on July 9 at our Fulshear facility. Training was provided by Delco/Remy. 35 mechanics from Lamar CISD and surrounding districts attended. Lunch was provided by Thomas Bus Gulf Coast.

During this school year, all 12 of our current technicians have completed a combined total of 284 hours of training.

STUDENT DISCIPLINE

7 student discipline reports were issued for the summer.

LAMAR CISD TRANSPORTATION

Date Range From : 06/01/2018 12:00:00 AM

To : 07/24/2018 11:59:00 PM

		Number of Transactions	Qty	Amount
Account : 001		VOCATIONAL		
Product :	01 Unleaded	1	5.000	\$10.85
Product :	02 #2 Diesel	23	548.800	\$1,167.05
Account Totals :		24	553.800	\$1,177.90
Account : 034		DISTRIBUTION		
Product :	01 Unleaded	55	962.100	\$2,087.76
Account Totals :		55	962.100	\$2,087.76
Account : 050		MAINTENANCE		
Product :	01 Unleaded	361	6007.500	\$12,568.54
Product :	02 #2 Diesel	208	1874.100	\$4,146.44
Account Totals :		569	7881.600	\$16,714.98
Account : 053		TECHNICAL SERVICES		
Product :	01 Unleaded	33	459.600	\$957.12
Account Totals :		33	459.600	\$957.12
Account : 060		Transportation		
Product :	01 Unleaded	66	860.700	\$1,747.06
Product :	02 #2 Diesel	659	22330.900	\$48,507.98
Account Totals :		725	23191.600	\$50,255.03
Account : 080		SECURITY		
Product :	01 Unleaded	51	706.600	\$1,528.02
Account Totals :		51	706.600	\$1,528.02
Account : 78		FOODSERVICE		
Product :	01 Unleaded	30	556.000	\$1,206.52
Account Totals :		30	556.000	\$1,206.52

Resource Persons: Leslie Haack, Deputy Superintendent of Support Services
Mike Jones, Director of Transportation

INFORMATION ITEM: BOARD POLICIES - FIRST READING

The following local policies are attached for review:

- Localized Policy Manual Update 110
- Localized Policy Manual Update 111

Local policies are customized to provide a procedure or guidelines to enforce the legal policies and district guidelines.

Resource Person: Dr. Thomas Randle, Superintendent

Localized Policy Manual Update 110

Lamar CISD

Remember: You can download a PDF of this update packet, annotated copies of the (LOCAL) policies, editable (LOCAL) text, and more on my.tasb.org under *Policy Service Resource Library: Local Manual Updates*.

Need help? Please call your policy consultant at 800-580-7529 or e-mail Policy.Service@TASB.org.

Contents

Overview	1
(LEGAL) vs. (LOCAL) Policies: Remember the Difference	2
How to Place Policy Changes on the Agenda for Board Action	3
How to Notify Policy Service of Board Action	3
How to Keep Minutes	3
How to Maintain Your Historical Record	4
How to Keep Your Administrative Regulations Current	4
Disclaimer and Copyright	4

Overview

Update 110 focuses on updating and reorganizing several policies in the BB series of the policy manual addressing board member eligibility and qualifications, elections, and vacancies and removal from office. The policy on board elections has been divided into several codes for ease of use, and district choices about election processes are now located in BBB(LOCAL) rather than in the LEGAL policies to better match the structure of the other policies in the manual. CCA, addressing bond elections, and CPAB, addressing political advertising, were also updated as part of the elections review.

In addition to these changes, Update 110 includes several other policies affected by legislation from the 85th Legislative Session that were not included in Update 109.

Your Localized Update 110 packet also contains:

- **Explanatory Notes** describing the changes to each policy. Please note that, where appropriate, the Explanatory Notes ask you to verify that a particular policy reflects current district practice and to advise us of any changes needed so that our records and the district's policy manual accurately track the district's practice. Explanatory notes may also provide important information about policies not included in the update packet.
- **Vantage Points—A Board Member's Guide to Update 110**, which provides local officials a highly summarized first glance at the update. Please distribute the enclosed copies of *Vantage Points* to your board members with the review copies of the update.
- **Instructions** for incorporating this update into each of the district's Localized Policy Manuals after board adoption. Use the enclosed Instruction Sheet as a guide to which policies should be added, replaced, and removed from your manual.

(LEGAL) vs. (LOCAL) Policies: Remember the Difference

(LEGAL) policies:

- Reflect the ever-changing legal context for governance and management of the district
- Should inform local decision making
- Should NOT be adopted, but only reviewed

(LOCAL) policies:

- Require close attention by both the administration and the board
- Must reflect the practices of the district and the intentions of the board
- May only be changed by board action (adopt, revise, or repeal)

If your board adopts changes to the (LOCAL) policies contained in this packet, please notify your policy consultant.

How to Place Policy Changes on the Agenda for Board Action

Board action on Localized Update 110 must occur within a properly posted, open meeting of the board.

- Update 110 may be addressed on the agenda posting as “Policy Update 110, affecting (LOCAL) policies (see attached list of codes).”
- You may use the “Agenda Posting (LOCAL) Policy List” provided online in *Local Manual Updates* and attach that list to the posting, or you may compile a list of (LOCAL) policy codes, titles, and subtitles from the material provided below.
- **BoardBook** compilers should use “Policy Update 110, affecting (LOCAL) policies” as the agenda item and, as agenda sub-items, the policy code, title, and subtitle of each of the (LOCAL) policies affected by the update.
- Here is a suggested motion for board action on Localized Update 110:
“I move that the board add, revise, or delete (LOCAL) policies as recommended by TASB Policy Service and according to the Instruction Sheet for TASB Localized Policy Manual Update 110 [with the following changes:]”

How to Notify Policy Service of Board Action

Notify Policy Service of the board’s action on Update 110 using the Update 110 Adoption Notification Form, enclosed, so Policy Service records remain accurate.

How to Keep Minutes

The board’s action on Localized Update 110 must be reflected in board minutes. Your minutes should include:

- The list of proposed (LOCAL) policy actions, such as the Instruction Sheet—annotated to reflect any changes made by the board
- The Explanatory Notes for the update (filed as an attachment to the minutes)
- Copies of new, replaced, or rescinded (LOCAL) policies

How to Maintain Your Historical Record

To construct a separate historical record of the manual, you must track the history of individual (LOCAL) policies. You should maintain a permanent historical record of every (LOCAL) policy adopted, revised, or rescinded by the board.

At a minimum, this record should include the following key pieces of information:

- Policy code
- Date of board action
- Text of policy

For more guidance on maintaining this record, please refer to:

- [*The Administrator's Guide to Policy Management*](#)
- [Tutorial videos](#) on handling an update

These guides are available in the myTASB *Policy Service Resource Library*.

How to Keep Your Administrative Regulations Current

Inspect your administrative procedures and documents—including EXHIBITS, REGULATIONS, handbooks, and guides—that may be affected by Update 110 policy changes.

If you must make changes to the REGULATIONS or EXHIBITS contained in your board policy manual, please notify your policy consultant.

Disclaimer and Copyright

PLEASE NOTE: This information is provided for educational purposes only to facilitate a general understanding of the law or other regulatory matter. This information is neither an exhaustive treatment on the subject nor is this intended to substitute for the advice of an attorney or other professional adviser. Consult with your attorney or professional adviser to apply these principles to specific fact situations.

Entire localized update packet © 2018 Texas Association of School Boards, Inc. All rights reserved.

Instruction Sheet

TASB Localized Policy Manual Update 110

District Lamar CISD

Code	Action To Be Taken	Note
ATTN (NOTE)	No policy enclosed	See explanatory note
B (LEGAL)	Replace table of contents	Revised table of contents
BBA (LEGAL)	Replace policy	Revised policy
BBB (LEGAL)	Replace policy	Revised policy
BBB (LOCAL)	Replace policy	Revised policy
BBBA (LEGAL)	Replace policy	Revised policy
BBBB (LEGAL)	Replace policy	Revised policy
BBBC (LEGAL)	ADD policy	See explanatory note
BBBD (LEGAL)	ADD policy	See explanatory note
BBC (LEGAL)	Replace policy	Revised policy
CCA (LEGAL)	Replace policy	Revised policy
CPAB (LEGAL)	Replace policy	Revised policy

**BOARD MEMBERS
ELECTIONS**

**BBB
(LOCAL)**

Elections and Terms Elections of Trustees are held on odd-numbered years for four-year terms in cycles keyed off the years below:

Districts 1, 2, 3, and 6 2009, 2013, 2017, and so forth.

Districts 4, 5, and 7 2011, 2015, 2019, and so forth.

REVISED

Lamar CISD
079901

BOARD MEMBERS
ELECTIONS

BBB
(LOCAL)

Membership

The Board shall consist of seven members.

Method of Election

Election of Board members shall be by single-member districts.

Election Date

General election of Board members shall be on the May uniform election date.

Elections and Terms and Election Schedule

Board members shall be elected ~~Elections of Trustees are held on odd-numbered years~~ for four-year terms, with elections conducted biennially, as follows:

Districts 4, 5, and 7

The election for single-member districts 4, 5, and 7 shall be held -in 2019, 2023, 2027, and in four-year intervals thereafter. ~~cycles keyed off the years below:~~

Districts 1, 2, 3, and 6

The election for single-member districts 1, 2, 3, and 6 shall be held in 2021, 2025, 2029, and in four-year intervals thereafter.

Method of Voting

To be elected, a candidate must receive more votes than any other candidate for the single-member district.

Plurality

~~2009, 2013, 2017, and so forth.~~

~~Districts 4, 5, and 7~~

~~2011, 2015, 2019, and so forth.~~

Localized Policy Manual Update 111

Lamar CISD

Remember: You can download a PDF of this update packet, annotated copies of the (LOCAL) policies, editable (LOCAL) text, and more on my.tasb.org under *Policy Service Resource Library: Local Manual Updates*.

Need help? Please call your policy consultant at 800-580-7529 or e-mail Policy.Service@TASB.org.

Contents

Overview	1
Legal Services Update Memo.....	2
(LEGAL) vs. (LOCAL) Policies: Remember the Difference	2
How to Place Policy Changes on the Agenda for Board Action.....	3
How to Notify Policy Service of Board Action.....	3
How to Keep Minutes	3
How to Maintain Your Historical Record.....	4
How to Keep Your Administrative Regulations Current	4
Disclaimer and Copyright.....	4

Overview

Update 111 focuses primarily on amendments to the Administrative Code resulting from legislation from the 85th Legislative Session. Recommended changes to local policies address the following topics:

- Board member continuing education;
- Reports of fraud or financial impropriety;
- Emergency access to district facilities of contractors and subcontractors subject to criminal history review;
- Employee compensation during emergency closings;
- Reasonable suspicion alcohol and drug testing of employees; and
- Student excused absences for pursuing armed services enlistment.



Your Localized Update 111 packet also contains:

- **Explanatory Notes** describing the changes to each policy. Please note that, where appropriate, the Explanatory Notes ask you to verify that a particular policy reflects current district practice and to advise us of any changes needed so that our records and the district's policy manual accurately track the district's practice. Explanatory notes may also provide important information about policies not included in the update packet.
- **Vantage Points—A Board Member's Guide to Update 111**, which provides local officials a highly summarized first glance at the update. Please distribute the enclosed copies of *Vantage Points* to your board members with the review copies of the update.
- **Instructions** for incorporating this update into each of the district's Localized Policy Manuals after board adoption. Use the enclosed Instruction Sheet as a guide to which policies should be added, replaced, and removed from your manual.

Legal Services Update Memo

New with Update 111, TASB Legal Services' [Legal Issues in Update 111](https://www.tasb.org/Services/Policy-Service/myTASB/Vantage-Points/documents/legal_issues_u111.aspx) memo (available on myTASB at https://www.tasb.org/Services/Policy-Service/myTASB/Vantage-Points/documents/legal_issues_u111.aspx) describes common legal concerns specific to the local policies recommended in this update for your consideration prior to board adoption of any local policies. Local policies will not be sent for a separate review by Legal Services as part of the update process. If after reviewing the memo you have questions about any specific provisions in your local policies, please contact TASB Legal Services at 800-580-5345.

(LEGAL) vs. (LOCAL) Policies: Remember the Difference

(LEGAL) policies:

- Reflect the ever-changing legal context for governance and management of the district
- Should inform local decision making
- Should NOT be adopted, but only reviewed

(LOCAL) policies:

- Require close attention by both the administration and the board
- Must reflect the practices of the district and the intentions of the board



- May only be changed by board action (adopt, revise, or repeal)

If your board adopts changes to the (LOCAL) policies contained in this packet, please notify your policy consultant.

How to Place Policy Changes on the Agenda for Board Action

Board action on Localized Update 111 must occur within a properly posted, open meeting of the board.

- Update 111 may be addressed on the agenda posting as “Policy Update 111, affecting (LOCAL) policies (see attached list of codes).”
- You may use the “Agenda Posting (LOCAL) Policy List” provided online in *Local Manual Updates* and attach that list to the posting, or you may compile a list of (LOCAL) policy codes, titles, and subtitles from the material provided below.
- **BoardBook** compilers should use “Policy Update 111, affecting (LOCAL) policies” as the agenda item and, as agenda sub-items, the policy code, title, and subtitle of each of the (LOCAL) policies affected by the update.
- Here is a suggested motion for board action on Localized Update 111:

“I move that the board add, revise, or delete (LOCAL) policies as recommended by TASB Policy Service and according to the Instruction Sheet for TASB Localized Policy Manual Update 111 [with the following changes:]”

How to Notify Policy Service of Board Action

Notify Policy Service of the board’s action on Update 111 using the Update 111 Adoption Notification Form, enclosed, so Policy Service records remain accurate.

How to Keep Minutes

The board’s action on Localized Update 111 must be reflected in board minutes. Your minutes should include:

- The list of proposed (LOCAL) policy actions, such as the Instruction Sheet—annotated to reflect any changes made by the board
- The Explanatory Notes for the update (filed as an attachment to the minutes)
- Copies of new, replaced, or rescinded (LOCAL) policies



How to Maintain Your Historical Record

To construct a separate historical record of the manual, you must track the history of individual (LOCAL) policies. You should maintain a permanent historical record of every (LOCAL) policy adopted, revised, or rescinded by the board.

At a minimum, this record should include the following key pieces of information:

- Policy code
- Date of board action
- Text of policy

For more guidance on maintaining this record, please refer to:

- [*The Administrator's Guide to Policy Management*](#)
- [Tutorial videos](#) on handling an update

These guides are available in the myTASB *Policy Service Resource Library*.

How to Keep Your Administrative Regulations Current

Inspect your administrative procedures and documents—including EXHIBITS, REGULATIONS, handbooks, and guides—that may be affected by Update 111 policy changes.

If you must make changes to the REGULATIONS or EXHIBITS contained in your board policy manual, please notify your policy consultant.

Disclaimer and Copyright

PLEASE NOTE: This information is provided for educational purposes only to facilitate a general understanding of the law or other regulatory matter. This information is neither an exhaustive treatment on the subject nor is this intended to substitute for the advice of an attorney or other professional adviser. Consult with your attorney or professional adviser to apply these principles to specific fact situations.

Entire localized update packet © 2018 Texas Association of School Boards, Inc. All rights reserved.

Instruction Sheet

TASB Localized Policy Manual Update 111

District Lamar CISD

Code	Action To Be Taken	Note
ATTN (NOTE)	No policy enclosed	See explanatory note
AF (LEGAL)	Replace policy	Revised policy
AID (LEGAL)	Replace policy	Revised policy
BBD (LEGAL)	Replace policy	Revised policy
BBD (LOCAL)	Replace policy	Revised policy
BJC (LEGAL)	Replace policy	Revised policy
BJCE (LEGAL)	Replace policy	Revised policy
BJCG (LEGAL)	Replace policy	Revised policy
BR (LEGAL)	Replace policy	Revised policy
CAA (LOCAL)	Replace policy	Revised policy
CBB (LEGAL)	Replace policy	Revised policy
CDA (LEGAL)	Replace policy	Revised policy
CFA (LEGAL)	Replace policy	Revised policy
CJA (LEGAL)	Replace policy	Revised policy
CJA (LOCAL)	ADD policy	See explanatory note
CKE (LEGAL)	Replace policy	Revised policy
CLB (LEGAL)	Replace policy	Revised policy
CMD (LEGAL)	Replace policy	Revised policy
CNB (LEGAL)	Replace policy	Revised policy
CO (LEGAL)	Replace policy	Revised policy
CQA (LEGAL)	Replace policy	Revised policy
CRD (LEGAL)	Replace policy	Revised policy
CRG (LEGAL)	Replace policy	Revised policy
CS (LEGAL)	Replace policy	Revised policy
DBA (LEGAL)	Replace policy	Revised policy
DBAA (LEGAL)	Replace policy	Revised policy
DC (LEGAL)	Replace policy	Revised policy
DCE (LEGAL)	Replace policy	Revised policy
DEA (LOCAL)	Replace policy	Revised policy
DF (LEGAL)	Replace policy	Revised policy
DFBA (LEGAL)	Replace policy	Revised policy
DH (LEGAL)	Replace policy	Revised policy

Instruction Sheet
TASB Localized Policy Manual Update 111

DH	(LOCAL)	No policy enclosed	See explanatory note
DHB	(LEGAL)	Replace policy	Revised policy
DHE	(LOCAL)	Replace policy	Revised policy
DI	(LOCAL)	DELETE policy	See explanatory note
DP	(LEGAL)	Replace policy	Revised policy
E	(LEGAL)	Replace table of contents	Revised table of contents
EB	(LEGAL)	Replace policy	Revised policy
EC	(LEGAL)	Replace policy	Revised policy
EFB	(LEGAL)	Replace policy	Revised policy
EHAD	(LEGAL)	Replace policy	Revised policy
EHBAB	(LEGAL)	Replace policy	Revised policy
EHBAD	(LEGAL)	Replace policy	Revised policy
EHBAE	(LEGAL)	Replace policy	Revised policy
EHBC	(LEGAL)	Replace policy	Revised policy
EHBD	(LEGAL)	Replace policy	Revised policy
EHDD	(LEGAL)	Replace policy	Revised policy
EI	(LEGAL)	Replace policy	Revised policy
EIC	(LEGAL)	Replace policy	Revised policy
EIF	(LEGAL)	Replace policy	Revised policy
EJ	(LEGAL)	DELETE policy	See explanatory note
EKB	(LEGAL)	Replace policy	Revised policy
EKBA	(LEGAL)	Replace policy	Revised policy
EL	(LEGAL)	Replace policy	Revised policy
ELA	(LEGAL)	ADD policy	See explanatory note
FD	(LEGAL)	Replace policy	Revised policy
FEA	(LOCAL)	Replace policy	Revised policy
FEB	(LEGAL)	Replace policy	Revised policy
FFAA	(LEGAL)	Replace policy	Revised policy
FFAB	(LEGAL)	Replace policy	Revised policy
FFEA	(LEGAL)	Replace policy	Revised policy
FFH	(LEGAL)	Replace policy	Revised policy
FOCA	(LEGAL)	Replace policy	Revised policy
FOF	(LEGAL)	Replace policy	Revised policy
GBA	(LEGAL)	Replace policy	Revised policy

Instruction Sheet
TASB Localized Policy Manual Update 111

GKA (LOCAL)	No policy enclosed	See explanatory note
-------------	--------------------	----------------------

BOARD MEMBERS
TRAINING AND ORIENTATION

BBD
(LOCAL)

**Public Information
Coordinator**

The Superintendent shall fulfill the responsibilities of the public information coordinator and shall receive, on behalf of Board members, the training specified by Government Code 552.012. [See GBAA]

REVISED

Lamar CISD
079901

BOARD MEMBERS
TRAINING AND ORIENTATION

BBD
(LOCAL)

**Public Information
Coordinator**

The Superintendent shall fulfill the responsibilities of the public information coordinator and shall receive, on behalf of Board members, the training specified by Government Code 552.012. [See GBAA]

**Reporting
Continuing
Education Credit**

The Board President shall announce the status of each Board member's continuing education credit. The announcement shall be made annually at the last regular Board meeting before the District's uniform election date, whether or not an election is held. The announcement shall be reflected in the meeting minutes and, when necessary, posted on the District's website in accordance with law.

DATE ISSUED: 7/10/2018~~5/15/2011~~
UPDATE 11190
BBD(LOCAL)-A

ADOPTED:

1 of 1

All Trustees, employees, vendors, contractors, agents, consultants, volunteers, and any other parties who are involved in the District's financial transactions shall act with integrity and diligence in duties involving the District's fiscal resources.

Note: See the following policies and/or administrative regulations regarding conflicts of interest, ethics, and financial oversight:

- Code of ethics:
for Board members—BBF
for employees—DH
- Financial conflicts of interest:
for public officials—BBFA
for all employees—DBD
for vendors—CHE
- Compliance with state and federal grant and award requirements: CB, CBB
- Financial conflicts and gifts and gratuities regarding federal funds: CB, CBB
- Systems for monitoring the District's investment program: CDA
- Budget planning and evaluation: CE
- Compliance with accounting regulations: CFC
- Activity fund management: CFD
- Criminal history record information for employees: DBAA, DC
- Disciplinary action for fraud by employees: DCD, DCE, and DF series

Fraud and Financial Impropriety

The District prohibits fraud and financial impropriety, as defined below, in the actions of its Trustees, employees, vendors, contractors, agents, consultants, volunteers, and others seeking or maintaining a business relationship with the District.

Definition

Fraud and financial impropriety shall include but not be limited to:

1. Forgery or unauthorized alteration of any document or account belonging to the District.
2. Forgery or unauthorized alteration of a check, bank draft, or any other financial document.

FISCAL MANAGEMENT GOALS AND OBJECTIVES
FINANCIAL ETHICS

CAA
(LOCAL)

3. Misappropriation of funds, securities, supplies, or other District assets, including employee time.
4. Impropriety in the handling of money or reporting of District financial transactions.
5. Profiteering as a result of insider knowledge of District information or activities.
6. Unauthorized disclosure of confidential or proprietary information to outside parties.
7. Unauthorized disclosure of investment activities engaged in or contemplated by the District.
8. Accepting or seeking anything of material value from contractors, vendors, or other persons providing services or materials to the District, except as otherwise permitted by law or District policy. [See CB, DBD]
9. Inappropriately destroying, removing, or using records, furniture, fixtures, or equipment.
10. Failure to provide financial records required by federal, state, or local entities.
11. Failure to disclose conflicts of interest as required by law or District policy.
12. Any other dishonest act regarding the finances of the District.
13. Failure to comply with requirements imposed by law, the awarding agency, or a pass-through entity for state and federal awards.

Financial Controls and Oversight

Each employee who supervises or prepares District financial reports or transactions shall set an example of honest and ethical behavior and shall actively monitor his or her area of responsibility for fraud and financial impropriety.

Fraud Prevention

The Superintendent or designee shall maintain a system of internal controls to deter and monitor for fraud or financial impropriety in the District.

Reports

Any person who suspects fraud or financial impropriety in the District shall report the suspicions immediately to any supervisor, the Superintendent or designee, the Board President, or local law enforcement.

Reports of suspected fraud or financial impropriety shall be treated as confidential to the extent permitted by law. Limited disclosure may be necessary to complete a full investigation or to comply with

FISCAL MANAGEMENT GOALS AND OBJECTIVES
FINANCIAL ETHICS

CAA
(LOCAL)

law. All employees involved in an investigation shall be advised to keep information about the investigation confidential.

Protection from Retaliation

Neither the Board nor any District employee shall unlawfully retaliate against a person who in good faith reports perceived fraud or financial impropriety. [See DG]

Fraud Investigations

In coordination with legal counsel and other internal or external departments or agencies, as appropriate, the Superintendent, Board President, or a designee shall promptly investigate reports of potential fraud or financial impropriety.

Response

If an investigation substantiates a report of fraud or financial impropriety, the Superintendent or designee shall promptly inform the Board of the report, the investigation, and any responsive action taken or recommended by the administration.

If an employee is found to have committed fraud or financial impropriety, the Superintendent or designee shall take or recommend appropriate disciplinary action, which may include termination of employment. If a contractor or vendor is found to have committed fraud or financial impropriety, the District shall take appropriate action, which may include cancellation of the District's relationship with the contractor or vendor.

When circumstances warrant, the Board, Superintendent, or designee may refer matters to appropriate law enforcement or regulatory authorities. In cases involving monetary loss to the District, the District may seek to recover lost or misappropriated funds.

The final disposition of the matter and any decision to file a criminal complaint or to refer the matter to the appropriate law enforcement or regulatory agency for independent investigation shall be made in consultation with legal counsel.

Federal Awards Disclosure

The District shall disclose, in a timely manner in writing to the federal awarding agency or pass-through entity, all violations of federal criminal law involving fraud, bribery, or gratuity violations potentially affecting a federal grant award. [See CBB]

Analysis of Fraud

After any investigation substantiates a report of fraud or financial impropriety, the Superintendent or designee shall analyze conditions or factors that may have contributed to the fraudulent or improper activity. The Superintendent or designee shall ensure that appropriate administrative procedures are developed and implemented to prevent future misconduct. These measures shall be presented to the Board for review.

FISCAL MANAGEMENT GOALS AND OBJECTIVES
FINANCIAL ETHICS

CAA
(LOCAL)

**Communications /
Campaign
Contributions**

Board members, employees, vendors, contractors, subcontractors, service providers, lobbyists, intermediaries, brokers, and consultants shall act with integrity in connection with the District's procurement of goods and services. Except as provided below, political contributions, gifts, donations, or any other items of value, as well as communications regarding solicitations (including invitations for bids, requests for proposals, requests for qualifications, or any other form of solicitation), shall be prohibited from the date a solicitation is first advertised through 30 days after any award or selection is made under the procurement:

1. Between a potential vendor, contractor, subcontractor, service provider, respondent, offeror, lobbyist, intermediary, broker or consultant and any Board member or candidate who has filed to run for a Board member position;
2. Between any Board member and any member of a selection committee or evaluation committee; and
3. Between any Board member and administrator or employee.

The communications prohibition shall not apply to pre-bid or pre-proposal conferences, emergency contracts as allowed under Texas law, and presentations to the Board during a duly noticed public meeting.

Violation of this policy shall be considered unethical conduct and may result in the termination of any resulting selection or contract, as well as disbarment and/or disqualification from current and future procurement solicitations.

All Trustees, employees, vendors, contractors, agents, consultants, volunteers, and any other parties who are involved in the District's financial transactions shall act with integrity and diligence in duties involving the District's fiscal resources.

Note: See the following policies and/or administrative regulations regarding conflicts of interest, ethics, and financial oversight:

- Code of ethics:
 - for Board members—BBF
 - for employees—DH
- Financial conflicts of interest:
 - for public officials—BBFA
 - for all employees—DBD
 - for vendors—CHE
- Compliance with state and federal grant and award requirements: CB, CBB
- Financial conflicts and gifts and gratuities regarding federal funds: CB, CBB
- Systems for monitoring the District's investment program: CDA
- Budget planning and evaluation: CE
- Compliance with accounting regulations: CFC
- Activity fund management: CFD
- Criminal history record information for employees: DBAA, DC
- Disciplinary action for fraud by employees: DCD, DCE, and DF series

~~**Note:** See the following policies and/or administrative regulations regarding conflicts of interest, ethics, and financial oversight:~~

- ~~• Code of ethics:

 - for Board members—BBF
 - for employees—DH~~
- ~~• Financial conflicts of interest:

 - for public officials—BBFA~~

~~for all employees—DBD
for vendors—CHE~~

- ~~• Compliance with state and federal grant and award requirements: CB, CBB~~
- ~~• Financial conflicts and gifts and gratuities regarding federal funds: CB, CBB~~
- ~~• Systems for monitoring the District's investment program: CDA~~
- ~~• Budget planning and evaluation: CE~~
- ~~• Compliance with accounting regulations: CFG~~
- ~~• Activity fund management: CFD~~
- ~~• Criminal history record information for employees: DBAA, DG~~
- ~~• Disciplinary action for fraud by employees: DGD, DCE, and DF series~~

Fraud and Financial Impropriety

The District prohibits fraud and financial impropriety, as defined below, in the actions of its Trustees, employees, vendors, contractors, agents, consultants, volunteers, and others seeking or maintaining a business relationship with the District.

Definition

Fraud and financial impropriety shall include but not be limited to:

1. Forgery or unauthorized alteration of any document or account belonging to the District.
2. Forgery or unauthorized alteration of a check, bank draft, or any other financial document.
3. Misappropriation of funds, securities, supplies, or other District assets, including employee time.
4. Impropriety in the handling of money or reporting of District financial transactions.
5. Profiteering as a result of insider knowledge of District information or activities.
6. Unauthorized disclosure of confidential or proprietary information to outside parties.
7. Unauthorized disclosure of investment activities engaged in or contemplated by the District.

FISCAL MANAGEMENT GOALS AND OBJECTIVES
FINANCIAL ETHICS

CAA
(LOCAL)

8. Accepting or seeking anything of material value from contractors, vendors, or other persons providing services or materials to the District, except as otherwise permitted by law or District policy. [See CB, DBD]
9. Inappropriately destroying, removing, or using records, furniture, fixtures, or equipment.
10. Failure to provide financial records required by federal, state, or local entities.
11. Failure to disclose conflicts of interest as required by law or District policy.
12. Any other dishonest act regarding the finances of the District.
13. Failure to comply with requirements imposed by law, the awarding agency, or a pass-through entity for state and federal awards.

Financial Controls and Oversight

Each employee who supervises or prepares District financial reports or transactions shall set an example of honest and ethical behavior and shall actively monitor his or her area of responsibility for fraud and financial impropriety.

Fraud Prevention

The Superintendent or designee shall maintain a system of internal controls to deter and monitor for fraud or financial impropriety in the District.

Reports

Any person who suspects fraud or financial impropriety in the District shall report the suspicions immediately to [a person with authority to investigate the suspicions, including](#) any supervisor, the Superintendent or designee, the Board President, or local law enforcement.

Reports of suspected fraud or financial impropriety shall be treated as confidential to the extent permitted by law. Limited disclosure may be necessary to complete a full investigation or to comply with law. All employees involved in an investigation shall be advised to keep information about the investigation confidential.

Protection from Retaliation

Neither the Board nor any District employee shall unlawfully retaliate against a person who in good faith reports perceived fraud or financial impropriety. [See DG]

Fraud Investigations

In coordination with legal counsel and other internal or external departments or agencies, as appropriate, the Superintendent, Board President, or a designee shall promptly investigate reports of potential fraud or financial impropriety.

Response

DATE ISSUED: ~~7/10/2018~~ 3/2016
UPDATE 111 LDU-2016-05
CAA(LOCAL)-X

ADOPTED:

3 of 5

If an investigation substantiates a report of fraud or financial impropriety, the Superintendent or designee shall promptly inform the Board of the report, the investigation, and any responsive action taken or recommended by the administration.

If an employee is found to have committed fraud or financial impropriety, the Superintendent or designee shall take or recommend appropriate disciplinary action, which may include termination of employment. If a contractor or vendor is found to have committed fraud or financial impropriety, the District shall take appropriate action, which may include cancellation of the District's relationship with the contractor or vendor.

When circumstances warrant, the Board, Superintendent, or designee may refer matters to appropriate law enforcement or regulatory authorities. In cases involving monetary loss to the District, the District may seek to recover lost or misappropriated funds.

The final disposition of the matter and any decision to file a criminal complaint or to refer the matter to the appropriate law enforcement or regulatory agency for independent investigation shall be made in consultation with legal counsel.

**Federal Awards
Disclosure**

The District shall disclose, in a timely manner in writing to the federal awarding agency or pass-through entity, all violations of federal criminal law involving fraud, bribery, or gratuity violations potentially affecting a federal grant award. [See CBB]

Analysis of Fraud

After any investigation substantiates a report of fraud or financial impropriety, the Superintendent or designee shall analyze conditions or factors that may have contributed to the fraudulent or improper activity. The Superintendent or designee shall ensure that appropriate administrative procedures are developed and implemented to prevent future misconduct. These measures shall be presented to the Board for review.

**Communications /
Campaign
Contributions**

Board members, employees, vendors, contractors, subcontractors, service providers, lobbyists, intermediaries, brokers, and consultants shall act with integrity in connection with the District's procurement of goods and services. Except as provided below, political contributions, gifts, donations, or any other items of value, as well as communications regarding solicitations (including invitations for bids, requests for proposals, requests for qualifications, or any other form of solicitation), shall be prohibited from the date a solicitation is first advertised through 30 days after any award or selection is made under the procurement:

1. Between a potential vendor, contractor, subcontractor, service provider, respondent, offeror, lobbyist, intermediary, broker or

FISCAL MANAGEMENT GOALS AND OBJECTIVES
FINANCIAL ETHICS

CAA
(LOCAL)

consultant and any Board member or candidate who has filed to run for a Board member position;

2. Between any Board member and any member of a selection committee or evaluation committee; and
3. Between any Board member and administrator or employee.

The communications prohibition shall not apply to pre-bid or pre-proposal conferences, emergency contracts as allowed under Texas law, and presentations to the Board during a duly noticed public meeting.

Violation of this policy shall be considered unethical conduct and may result in the termination of any resulting selection or contract, as well as disbarment and/or disqualification from current and future procurement solicitations.

Emergencies

In an emergency due to a health or safety concern, a reasonably unforeseeable situation, or other exigent circumstance, the District employee who is in charge of the facility shall be authorized to determine whether an employee of a contracting or subcontracting entity who does not have the required criminal history record information (CHRI) review or who has a disqualifying conviction will be permitted to enter a District facility.

If allowed to enter the facility, the employee of the contracting or subcontracting entity shall be accompanied by a District employee at all times.

**COMPENSATION AND BENEFITS
COMPENSATION PLAN**

DEA
(LOCAL)

The Superintendent shall recommend an annual compensation plan for all District employees. The compensation plan may include wage and salary structures, stipends, benefits, and incentives. [See also DEAA] The recommended plan shall support District goals for hiring and retaining highly qualified employees. The Board shall review and approve the compensation plan to be used by the District. The Board shall also determine the total compensation package for the Superintendent. [See BJ series]

Pay Administration

The Superintendent shall implement the compensation plan and establish procedures for plan administration consistent with the budget. The Superintendent or designee shall classify each job title within the compensation plan based on the qualifications, duties, and market value of the position.

Annualized Salary

The District shall pay all salaried employees over 12 months in equal monthly or bimonthly installments, regardless of the number of months employed during the school year. Salaried employees hired during the school year shall be paid in accordance with administrative regulations.

Pay Increases

The Superintendent shall recommend to the Board an amount for employee pay increases as part of the annual budget. The Superintendent or designee shall determine pay adjustments for individual employees, within the approved budget following established procedures.

*Mid-Year Pay
Increases*

Contract
Employees

A contract employee's pay may be increased after performance on the contract has begun only if authorized by the compensation plan of the District or there is a change in the employee's job assignment or duties during the term of the contract that warrants additional compensation. Any such changes in pay that do not conform with the compensation plan shall require Board approval. [See DEA(LEGAL) for provisions on pay increases and public hearing requirements]

Non-Contract
Employees

The Superintendent may grant a pay increase to a noncontract employee after duties have begun because of a change in the employee's job assignment or to address pay equity. The Superintendent shall report any such pay increases to the Board at the next regular meeting.

Pay During Closing

During an emergency closing for which the workdays are not scheduled to be made up at a later date, all exempt employees shall continue to be paid for their regular duty schedule regardless of whether the employees are required to report to work. The Board shall, by resolution or other Board action, set the parameters for payment during closings and reflect the purpose served by the

COMPENSATION AND BENEFITS
COMPENSATION PLAN

DEA
(LOCAL)

expenditure. [See EB for the authority to close schools] Makeup days may be scheduled at the District's option.

Nonexempt employees who are required to work during an emergency closing shall be paid at the rate of one and one-half times their regular rate of pay for all hours worked up to 40 hours per week. Overtime for time worked over 40 hours in a week shall be calculated and paid according to law. [See DEAB] The Superintendent or designee shall approve payments and ensure that accurate time records are kept of actual hours worked during emergency closings. Nonexempt employees who are not required to report to work must use compensatory time earned previously, use accrued leave time, or must make up work hours missed. The District may waive the requirement to make up the hours missed in certain situations.

REVISED

Lamar CISD
079901

COMPENSATION AND BENEFITS
COMPENSATION PLAN

DEA
(LOCAL)

The Superintendent shall recommend an annual compensation plan for all District employees. The compensation plan may include wage and salary structures, stipends, benefits, and incentives. [See also DEAA] The recommended plan shall support District goals for hiring and retaining highly qualified employees. The Board shall review and approve the compensation plan to be used by the District. The Board shall also determine the total compensation package for the Superintendent. [See BJ series]

Pay Administration

The Superintendent shall implement the compensation plan and establish procedures for plan administration consistent with the budget. The Superintendent or designee shall classify each job title within the compensation plan based on the qualifications, duties, and market value of the position.

Annualized Salary

The District shall pay all salaried employees over 12 months in equal monthly or bimonthly installments, regardless of the number of months employed during the school year. Salaried employees hired during the school year shall be paid in accordance with administrative regulations.

Pay Increases

The Superintendent shall recommend to the Board an amount for employee pay increases as part of the annual budget. The Superintendent or designee shall determine pay adjustments for individual employees, within the approved budget following established procedures.

*Mid-Year Pay
Increases*

Contract
Employees

A contract employee's pay may be increased after performance on the contract has begun only if authorized by the compensation plan of the District or there is a change in the employee's job assignment or duties during the term of the contract that warrants additional compensation. Any such changes in pay that do not conform with the compensation plan shall require Board approval. [See DEA(LEGAL) for provisions on pay increases and public hearing requirements]

~~Noncontract~~
~~-Contract~~
Employees

The Superintendent may grant a pay increase to a noncontract employee after duties have begun because of a change in the employee's job assignment or to address pay equity. The Superintendent shall report any such pay increases to the Board at the next regular meeting.

Pay During Closing

During an emergency ~~closure~~~~closing for which the workdays are not scheduled to be made up at a later date~~, all exempt employees shall continue to be paid for their regular duty schedule ~~unless otherwise provided by Board action. Following an emergency closure, the~~ ~~regardless of whether the employees are required to report to work. The~~ Board shall ~~adopt a, by~~ resolution or ~~take~~ other Board

DATE ISSUED: 7/10/2018~~5/29/2015~~
UPDATE 111402
DEA(LOCAL)-X

COMPENSATION AND BENEFITS
COMPENSATION PLAN

DEA
(LOCAL)

Premium Pay
During Disasters

action establishing, ~~set~~ the purpose and parameters for such payments. ~~payment during closings and reflect the purpose served by the expenditure.~~ [See EB for the authority to close schools]
Makeup days may be scheduled at the District's option.

Nonexempt employees who are required to work during an emergency closing for a disaster, as declared by a federal, state, or local official or the Board, shall be paid at the rate of one and one-half times their regular rate of pay for all hours worked up to 40 hours per week. Overtime for time worked over 40 hours in a week shall be calculated and paid according to law. [See DEAB]- The Superintendent or designee shall approve payments and ensure that accurate time records are kept of actual hours worked during emergency closings.

-Nonexempt employees who are not required to report to work must use compensatory time earned previously, use accrued leave time, or ~~must~~ make up work hours missed. The District may waive the requirement to make up the hours missed in certain situations.

EMPLOYEE STANDARDS OF CONDUCT
SEARCHES AND ALCOHOL/DRUG TESTING

DHE
(LOCAL)

**Reasonable
Suspicion Searches**

The District reserves the right to conduct searches when the District has reasonable suspicion to believe that a search will uncover evidence of work-related misconduct. The District may search the employee, the employee's personal items, work areas, lockers, and private vehicles parked on District premises or worksites or used in District business. Searches that reveal a violation of the District's standards of conduct may result in disciplinary action. [See DH]

Note: The following provisions apply to employees who are covered by the federal Department of Transportation (DOT) rules.

**Federally Required
DOT Testing
Program**

In accordance with DOT rules, the District shall establish an alcohol and controlled substances testing program to help prevent accidents and injuries resulting from the misuse of alcohol and controlled substances by the drivers of commercial motor vehicles, including school buses. The primary purpose of the testing program is to prevent impaired employees from performing safety-sensitive functions.

The Superintendent shall designate a District official who shall be responsible for ensuring that information is disseminated to employees covered under this testing program regarding prohibited driver conduct, alcohol and controlled substances tests, and the consequences that follow positive test results.

**Drug-Related
Violations**

The following constitute drug-related violations under the DOT rules:

1. Refusing to submit to a required test for alcohol or controlled substances.
2. Providing an adulterated, diluted, or a substituted specimen on an alcohol or controlled substances test.
3. Testing positive for alcohol, at a concentration of 0.04 or above, in a post-accident test.
4. Testing positive for controlled substances in a post-accident test.
5. Testing positive for alcohol, at a concentration of 0.04 or above, in a random test.
6. Testing positive for controlled substances in a random test.
7. Testing positive for alcohol, at a concentration of 0.04 or above, in a reasonable suspicion test.

EMPLOYEE STANDARDS OF CONDUCT
SEARCHES AND ALCOHOL/DRUG TESTING

DHE
(LOCAL)

8. Testing positive for controlled substances in a reasonable suspicion test.

An employee who operates a commercial motor vehicle, including a bus, and commits a drug-related DOT violation as defined above shall not be eligible for reinstatement as a driver.

Alcohol Results
Between 0.02 and
0.04

In accordance with DOT rules, a driver tested under this policy and found to have an alcohol concentration of 0.02 or greater, but less than 0.04, shall be suspended from driving duties for at least 24 hours.

[In the event of a subsequent positive test result for alcohol of 0.02 or greater but less than 0.04, see the disciplinary consequences at DISTRICT-IMPOSED CONSEQUENCES, below.]

Reasonable
Suspicion DOT
Testing

Only supervisors specifically trained in accordance with federal regulations may, based upon reasonable suspicion, remove a driver from a safety-sensitive position and require testing for alcohol and/or controlled substances. The determination of reasonable suspicion shall be based on specific observations of the appearance, behavior, speech, or body odors of the driver whose motor ability, emotional equilibrium, or mental acuity seems to be impaired. Such observations must take place just preceding, during, or just after the period of the workday that the driver is on duty.

The observations may include indication of the chronic and withdrawal effects of controlled substances. Within 24 hours of the observed behavior, the supervisor shall provide a signed, written record documenting the observations leading to a controlled substance reasonable suspicion test.

**District-Imposed
Consequences**

In addition to the consequences established by federal law, a District employee confirmed to have violated the District's policy pertaining to alcohol or controlled substances, including a second or subsequent positive test result for alcohol of 0.02 or greater but less than 0.04, shall be subject to District-imposed discipline, as determined by his or her supervisor and the Superintendent. Such discipline may include any appropriate action from suspension without pay during the period of removal from safety-sensitive functions, up to and including termination of employment. [See DF series]

In cases where a driver is also employed in a nondriving capacity by the District, disciplinary action imposed for violation of alcohol and controlled substances policies shall apply to the employee's functions and duties that involve driving. Additionally, upon recommendation of the employee's supervisor, disciplinary measures up

EMPLOYEE STANDARDS OF CONDUCT
SEARCHES AND ALCOHOL/DRUG TESTING

DHE
(LOCAL)

to and including termination of employment with the District may be considered.

**Reasonable
Suspicion Searches**

The District reserves the right to conduct searches when the District has reasonable suspicion to believe that a search will uncover evidence of work-related misconduct. The District may search the employee, the employee's personal items, work areas, lockers, and private vehicles parked on District premises or worksites or used in District business. Searches that reveal a violation of the District's standards of conduct may result in disciplinary action. [See DH]

**Reasonable
Suspicion Alcohol
and Drug Testing**

The District may remove an employee from duty and require testing if there is reasonable suspicion that the employee is under the influence of alcohol or drugs used in violation of District policy. The determination of reasonable suspicion may be based on specific observations of the appearance, behavior, speech, or body odors of the employee whose motor ability, emotional equilibrium, or mental acuity seems to be impaired while on duty or other relevant information. Any employee who is asked to submit to drug or alcohol testing shall be given the opportunity to provide relevant information about prescription or nonprescription medications that may affect the screening.

A District employee who refuses to comply with a directive to submit to testing based upon reasonable suspicion shall be subject to disciplinary action, up to and including termination.

A District employee confirmed to have violated the District's policy pertaining to alcohol or drugs may be subject to disciplinary action. [See DF series and DH]

Note: The following provisions apply to employees who are covered by the federal Department of Transportation (DOT) rules.

**Federally Required
DOT Testing
Program**

In accordance with DOT rules, the District shall establish an alcohol and controlled substances testing program to help prevent accidents and injuries resulting from the misuse of alcohol and controlled substances by the drivers of commercial motor vehicles, including school buses. The primary purpose of the testing program is to prevent impaired employees from performing safety-sensitive functions.

The Superintendent shall designate a District official who shall be responsible for ensuring that information is disseminated to employees covered under this testing program regarding prohibited driver conduct, alcohol and controlled substances tests, and the consequences that follow positive test results.

EMPLOYEE STANDARDS OF CONDUCT
SEARCHES AND ALCOHOL/DRUG TESTING

DHE
(LOCAL)

Drug-Related
Violations

The following constitute drug-related violations under the DOT rules:

1. Refusing to submit to a required test for alcohol or controlled substances.
2. Providing an adulterated, diluted, or a substituted specimen on an alcohol or controlled substances test.
3. Testing positive for alcohol, at a concentration of 0.04 or above, in a post-accident test.
4. Testing positive for controlled substances in a post-accident test.
5. Testing positive for alcohol, at a concentration of 0.04 or above, in a random test.
6. Testing positive for controlled substances in a random test.
7. Testing positive for alcohol, at a concentration of 0.04 or above, in a reasonable suspicion test.
8. Testing positive for controlled substances in a reasonable suspicion test.

An employee who operates a commercial motor vehicle, including a bus, and commits a drug-related DOT violation as defined above shall not be eligible for reinstatement as a driver.

Alcohol Results
Between 0.02 and
0.04

In accordance with DOT rules, a driver tested under this policy and found to have an alcohol concentration of 0.02 or greater, but less than 0.04, shall be suspended from driving duties for at least 24 hours.

[In the event of a subsequent positive test result for alcohol of 0.02 or greater but less than 0.04, see the disciplinary consequences at [District-Imposed Consequences](#) ~~DISTRICT-IMPOSED CONSEQUENCES~~, below.]

Reasonable
Suspicion DOT
Testing

Only supervisors specifically trained in accordance with federal regulations may, based upon reasonable suspicion, remove a driver from a safety-sensitive position and require testing for alcohol and/or controlled substances. The determination of reasonable suspicion shall be based on specific observations of the appearance, behavior, speech, or body odors of the driver whose motor ability, emotional equilibrium, or mental acuity seems to be impaired. Such observations must take place just preceding, during, or just after the period of the workday that the driver is on duty.

The observations may include indication of the chronic and withdrawal effects of controlled substances. Within 24 hours of the observed behavior, the supervisor shall provide a signed, written record documenting the observations leading to a controlled substance reasonable suspicion test.

**District-Imposed
Consequences**

In addition to the consequences established by federal law, a District employee confirmed to have violated the District's policy pertaining to alcohol or controlled substances, including a second or subsequent positive test result for alcohol of 0.02 or greater but less than 0.04, shall be subject to District-imposed discipline, as determined by his or her supervisor and the Superintendent. Such discipline may include any appropriate action from suspension without pay during the period of removal from safety-sensitive functions, up to and including termination of employment. [See DF series]

In cases where a driver is also employed in a nondriving capacity by the District, disciplinary action imposed for violation of alcohol and controlled substances policies shall apply to the employee's functions and duties that involve driving. Additionally, upon recommendation of the employee's supervisor, disciplinary measures up to and including termination of employment with the District may be considered.

DELETE

Lamar-CISD
079901

EMPLOYEE WELFARE

DI
(LOCAL)

**Drug-Free
Awareness Program**

The District shall maintain a drug-free environment and shall establish, as needed, a drug-free awareness program complying with federal requirements. [See DH] The program shall provide applicable information to employees in the following areas:

1. The dangers of drug use and abuse in the workplace.
2. The District's policy of maintaining a drug-free environment. [See DH(LOCAL)]
3. Drug counseling, rehabilitation, and employee assistance programs that are available in the community, if any.
4. The penalties that may be imposed on employees for violation of drug use and abuse prohibitions. [See DH(LOCAL)]

**Employee
Responsibility**

All fees or charges associated with drug/alcohol abuse counseling or rehabilitation shall be the responsibility of the employee.

Students in violation of the compulsory attendance law shall be reported to the District attendance officer, who may institute court action as provided by law.

Excused Absences

In addition to excused absences required by law, the District shall excuse absences for the following purposes.

Higher Education
Visits

The District shall excuse a student for up to two days during the student's junior year and up to two days during the student's senior year to visit an accredited institution of higher education. A student shall be required to submit verification of such visits in accordance with administrative regulations.

Armed Services
Enlistment

The District shall excuse a student 17 years of age or older for up to four days during a school year for activities related to pursuing enlistment in a branch of the U.S. Armed Services or Texas National Guard. A student shall be required to submit verification of such activities in accordance with administrative regulations.

Early Voting or
Election Clerk

The District shall excuse a student for up to two days per school year to serve as an early voting or election clerk. A student shall be required to submit verification of service in accordance with administrative regulations.

[For extracurricular activity absences, see FM.]

**Withdrawal for
Nonattendance**

The District may initiate withdrawal of a student under the age of 19 for nonattendance under the following conditions:

1. The student has been absent ten consecutive school days;
and
2. Repeated efforts by the attendance officer and/or principal to locate the student have been unsuccessful.

[For District-initiated withdrawal of students 19 or older, see FEA(LEGAL).]

**Students Attending
Homeschools**

Students who are homeschooled are exempt from the compulsory attendance law to the same extent as students enrolled in other private schools.

Adequate documentation of homeschooling for withdrawal shall consist of either a statement of withdrawal in accordance with FD(LOCAL) indicating the date homeschooling began, or a signed and dated letter from a parent or guardian indicating that his or her child is being homeschooled and the date the homeschooling began.

The District may request from a parent or guardian a letter of assurance that a child is being educated using a curriculum designed

ATTENDANCE
COMPULSORY ATTENDANCE

FEA
(LOCAL)

to meet basic education goals of reading, spelling, grammar, mathematics, and a study of good citizenship.

Enforcing
Compulsory
Attendance

If a parent or guardian refuses to submit a requested statement or letter, or if the District has evidence that a school-aged child is not being homeschooled within legal requirements, the District may investigate further and, if warranted, shall pursue legal action to enforce the compulsory attendance law.

REVISED

Lamar CISD
079901

ATTENDANCE
COMPULSORY ATTENDANCE

FEA
(LOCAL)

Students in violation of the compulsory attendance law shall be reported to the District attendance officer, who may institute court action as provided by law.

Excused Absences

In addition to excused absences required by law, the District shall excuse absences for the following purposes.

Higher Education Visits

The District shall excuse a student for up to two days during the student's junior year and up to two days during the student's senior year to visit an accredited institution of higher education. A student shall be required to submit verification of such visits in accordance with administrative regulations.

Armed Services Enlistment

The District shall excuse a student 17 years of age or older for up to four days during his or her enrollment in high school-year for activities related to pursuing enlistment in a branch of the U.S. Armed Services or Texas National Guard. A student shall be required to submit verification of such activities in accordance with administrative regulations.

Early Voting or Election Clerk

The District shall excuse a student for up to two days per school year to serve as an early voting or election clerk. A student shall be required to submit verification of service in accordance with administrative regulations.

[For extracurricular activity absences, see FM.]

Withdrawal for Nonattendance

The District may initiate withdrawal of a student under the age of 19 for nonattendance under the following conditions:

1. The student has been absent ten consecutive school days; and
2. Repeated efforts by the attendance officer and/or principal to locate the student have been unsuccessful.

[For District-initiated withdrawal of students 19 or older, see FEA(LEGAL).]

Students Attending Homeschools

Students who are homeschooled are exempt from the compulsory attendance law to the same extent as students enrolled in other private schools.

Adequate documentation of homeschooling for withdrawal shall consist of either a statement of withdrawal in accordance with FD(LOCAL) indicating the date homeschooling began, or a signed and dated letter from a parent or guardian indicating that his or her child is being homeschooled and the date the homeschooling began.

ATTENDANCE
COMPULSORY ATTENDANCE

FEA
(LOCAL)

Enforcing
Compulsory
Attendance

The District may request from a parent or guardian a letter of assurance that a child is being educated using a curriculum designed to meet basic education goals of reading, spelling, grammar, mathematics, and a study of good citizenship.

If a parent or guardian refuses to submit a requested statement or letter, or if the District has evidence that a school-aged child is not being homeschooled within legal requirements, the District may investigate further and, if warranted, shall pursue legal action to enforce the compulsory attendance law.

**INFORMATION ITEM: LAMAR CISD WHOLE CHILD SAFETY
& WELLNESS MODEL**

Lamar CISD will be launching the Whole Child Safety & Wellness Model beginning the 2018-2019 school year. The model is a comprehensive approach that addresses the social and emotional care for our students. The model has (6) core domains to include: Social Well-being, Emotional Well-being, College & Career Readiness, Environmental Well-being, Mental Health, and Growth Mindset. The model incorporates a sense of character education components at its foundation, supported by the evidenced-based curriculum through Character 5.0.

To date the following activities are either in progress or completed:

- All Administrators have been introduced to the program and reviewed expectations of service delivery with fidelity.
- All counselors and Family Support Specialists will receive on-site Character Counts training August 14, 2018.
- All counselors will receive complete program execution materials to include, guidance lessons, group activities, campus newsletters, announcements, campus faculty training materials and collateral pieces for campus implementation beginning September 1, 2018.
- Banners (3 x 8 ft.) have been delivered to all JH's and HS's to have hung before school starts. There are banners for each Character Pillar.
- Secondary Fine Arts will be creating PSA's around each pillar to run during lunch time, advisories or on the school website beginning the 2nd week of September.
- Lamar CISD Website banner will feature the character pillar each month.
- The Student Support Services App will launch September 2018. This App will allow students 24/7 access to a qualified mental health professional via the Lamar CISD HOPE Line, access to anonymous Bullying Reporting via the Lamar CISD Speak Up reporting tool and access 24/7 to Crime Stoppers.
- Meetings have been held with Fine Arts and Athletics to create leadership opportunities for students to demonstrate and support the Character Pillar.
- All HS teachers will receive Mental Health First Aid Training during the back to school professional development days in August.
- September is National Childhood Cancer Awareness Month. The District will kick-off giving back with a Lamar CSID *Pay-It- Forward* initiative supporting Childhood Cancer. The *Make a "Change" for Kids with Cancer* will collect spare change during the month of September and donate it to Childhood Cancer Research.

Resource persons: Valerie Vogt, Chief Academic Officer
Dr. Jonathan Maxwell, Executive Director of Special Programs
Dr. Jennifer Roberts, Director Student Support Services

INFORMATION ITEM: SCHOOL SAFETY UPDATE

The District will provide an update on school safety procedures and communications.

Resource Person: Mike Rockwood, Chief of Staff
Dallis Warren, School Safety Coordinator